

8V128M.00-2

1 General information

- Modular mechanical design using plug-in modules
- Integrated line filter
- Integrated or optional external braking resistor
- Integrated electronic restart inhibit

2 Order data


Model number	Short description	Figure
	Servo drives	
8V128M.00-2	ACOPOS servo drive, 3x 400-480 V, 128 A, 64 kW, line filter, integrated braking resistor, DC bus power supply and electronic secure restart inhibit	
	Optional accessories	
	Braking resistors	
8B0W0045H000.000-1	Braking resistor, 450 W, 50 R, IP20, terminals	
8B0W0045H000.001-1	Braking resistor, 450 W, 50 R, IP65, terminals	
8B0W0079H000.000-1	Braking resistor, 790 W, 33 R, IP20, terminals	
8B0W0079H000.001-1	Braking resistor, 790 W, 33 R, IP65, terminals	
	Plug-in modules	
8AC110.60-3	ACOPOS plug-in module, CAN interface	
8AC114.60-2	ACOPOS plug-in module, POWERLINK V2 interface	
8AC120.60-1	ACOPOS plug-in module, EnDat encoder and sine incremental encoder interface	
8AC121.60-1	ACOPOS plug-in module, HIPERFACE interface	
8AC122.60-3	ACOPOS plug-in module, resolver interface 10 kHz	
8AC123.60-1	ACOPOS plug-in module, incremental encoder and SSI absolute encoder interface	
8AC125.60-1	ACOPOS plug-in module, BiSS/SSI SinCos/SSI interface	
8AC125.60-2	ACOPOS plug-in module, BiSS encoder interface 5 V, baud rate 6.25 Mbit/s	
8AC125.61-2	ACOPOS plug-in module, BiSS encoder interface 12 V, baud rate 6.25 Mbit/s	
8AC126.60-1	ACOPOS plug-in module, EnDat 2.2 encoder interface	
8AC130.60-1	ACOPOS plug-in module, 8 digital I/O configurable in pairs as 24 V input or as output 400/100 mA, 2 digital outputs 2 A, order TB712 terminal block separately	
8AC131.60-1	ACOPOS plug-in module, 2 analog inputs ± 10 V, 2 digital I/Os configurable as 24 V input or output 45 mA, order terminal block TB712 separately!	
	Included in delivery	
	Shielding component sets	
8X0030.00-1	ACOPOS shielding components set for 8V1640.xxx-x and 8V128M.xxx-x	
	Terminal sets	
8X0005.00-1	ACOPOS accessories, plug set for 8V1640.00 and 8V128M.00 (3 phase)	

Table 1: 8V128M.00-2 - Order data

3 Technical data

Model number	8V128M.00-2
General information	
B&R ID code	0x12F3
Slots for plug-in modules	4
Certifications	
CE	Yes
Functional safety ¹⁾	Yes
UL	cULus E225616 Power conversion equipment
EAC	Yes
KC	Yes

Table 2: 8V128M.00-2 - Technical data

Model number	8V128M.00-2
Mains connection	
Permissible network configurations	TT, TN ²⁾
Mains input voltage	3x 400 VAC to 480 VAC $\pm 10\%$
Frequency	50 / 60 Hz $\pm 4\%$
Installed load	Max. 98 kVA
Inrush current at 400 VAC	26 A
Switch-on interval	>10 s
Integrated line filter per EN 61800-3, category C3 ³⁾	Yes
Power dissipation at device nominal power without braking resistor	Approx. 3200 W
DC bus connection	
DC bus capacitance	6600 μF
24 VDC power supply	
Input voltage	24 VDC +25% / -20%
Input capacitance	32,800 μF
Current consumption at 24 VDC ⁴⁾	
Mains input voltage applied	- ⁵⁾
Mains input voltage not applied	Max. 5.7 A + 1.4 * (Current for motor holding brake + Current on 24 VDC output)
DC bus power supply	
Switch-on voltage	455 VDC
24 VDC output	
Output voltage	
Mains input voltage applied	22 to 24 VDC
Mains input voltage not applied	16.7 to 30 VDC ⁶⁾
Output current	Max. 0.5 A
Motor connection	
Quantity	1
Continuous current ⁷⁾	128 A _{eff}
Reduction of continuous current depending on ambient temperature	
Mains input voltage: 400 VAC	
Switching frequency 5 kHz	No reduction ⁸⁾
Switching frequency 10 kHz	1.65 A _{eff} per °C (starting at 52°C)
Switching frequency 20 kHz	1.65 A _{eff} per °C (starting at 12°C)
Mains input voltage: 480 VAC	
Switching frequency 5 kHz	No reduction ⁸⁾
Switching frequency 10 kHz	1.65 A _{eff} per °C (starting at 36°C)
Switching frequency 20 kHz	1.65 A _{eff} per °C (starting at 10°C) ⁹⁾
Reduction of continuous current depending on installation elevation	
Starting at 500 m above sea level	12.8 A _{eff} per 1000 m
Peak current	300 A _{eff}
Nominal switching frequency	5 kHz
Possible switching frequencies	5 / 10 / 20 kHz
Electrical stress of connected motor per IEC TS 60034-25 ¹⁰⁾	Limit value curve A
Max. motor cable length	25 m
Protective measures	
Overload protection	Yes
Short circuit and ground fault protection	Yes
Max. output frequency	598 Hz ¹¹⁾
Terminal connection cross section	
Flexible and fine-stranded wires	
With wire end sleeves	10 to 70 mm ²
Approbation data	
UL/C-UL-US	6 to 2/0 AWG
CSA	6 to 2/0 AWG
Motor holding brake connection	
Response threshold for open circuit monitoring	Approx. 210 mA
Max. output current	3 A
Max. number of switching cycles	Approx. 80000
Braking resistor	
Peak power int./ext.	8.5 / 250 kW
Continuous power int./ext.	0.24 / 24 kW ¹²⁾
Minimum braking resistance (ext.)	2.5 Ω
Rated current of built-in fuse	30 A (fast-acting)
Limit switch and reference inputs	
Quantity	3
Circuit	Sink
Electrical isolation	
Input - ACOPOS	Yes
Input - Input	No

Table 2: 8V128M.00-2 - Technical data

Model number	8V128M.00-2
Input voltage	
Nominal	24 VDC
Maximum	30 VDC
Switching threshold	
Low	<5 V
High	>15 V
Input current at nominal voltage	Approx. 4 mA
Switching delay	Max. 2.0 ms
Modulation compared to ground potential	Max. \pm 38 V
Enable inputs	
Quantity	1
Circuit	Sink
Electrical isolation	
Input - ACOPOS	Yes
Input voltage	
Nominal	24 VDC
Maximum	30 VDC
Input current at nominal voltage	Approx. 30 mA
Switching threshold	
Low	<5 V
High	>15 V
Switching delay	
Enable 0 \rightarrow 1, ready for PWM	Max. 100 μ s
Enable 1 \rightarrow 0, PWM off	Max. 2.0 ms
Modulation compared to ground potential	Max. \pm 38 V
OSSD signal connections ¹³⁾	Not permitted
Trigger inputs	
Quantity	2
Circuit	Sink
Electrical isolation	
Input - ACOPOS	Yes
Input - Input	No
Input voltage	
Nominal	24 VDC
Maximum	30 VDC
Switching threshold	
Low	<5 V
High	>15 V
Input current at nominal voltage	Approx. 10 mA
Switching delay	
Rising edge	52 μ s \pm 0.5 μ s (digitally filtered)
Falling edge	53 μ s \pm 0.5 μ s (digitally filtered)
Modulation compared to ground potential	Max. \pm 38 V
Electrical properties	
Discharge capacitance	5.4 μ F
Operating conditions	
Permissible mounting orientations	
Hanging vertically	Yes
Horizontal, face up	Yes
Standing horizontally	No
Installation elevation above sea level	
Nominal	0 to 500 m
Maximum ¹⁴⁾	2000 m
Pollution degree per EN 61800-5-1	2 (non-conductive pollution)
Overvoltage category per EN 61800-5-1	II
Degree of protection per EN 60529	IP20
Ambient conditions	
Temperature	
Operation	
Nominal	5 to 40°C
Maximum ¹⁵⁾	55°C
Storage	-25 to 55°C
Transport	-25 to 70°C
Relative humidity	
Operation	5 to 85%
Storage	5 to 95%
Transport	Max. 95% at 40°C

Table 2: 8V128M.00-2 - Technical data

Model number	8V128M.00-2
Mechanical properties	
Dimensions	
Width	402 mm
Height	460 mm
Depth	295 mm
Weight	33.8 kg

Table 2: 8V128M.00-2 - Technical data

- 1) Achievable safety classifications (safety integrity level, safety category, performance level) are documented in the user's manual (section "Safety technology").
- 2) In the USA, TT and TN power mains are commonly referred to as "Delta/Wye with grounded Wye neutral".
- 3) Limit values from EN 61800-3 C3 (second environment).
- 4) The current requirements depend on the configuration of the ACOPOS servo drive
The inrush current is significantly higher than the value for current consumption and can be estimated according to the input capacitance.
- 5) If the mains input voltage (3x 400 VAC to 480 VAC $\pm 10\%$) is applied, then the 24 VDC supply voltage for the ACOPOS servo drive is generated by the internal DC bus power supply, reducing the 24 VDC current consumption ($I_{24\text{VDC}}$) to 0.
- 6) If the mains input voltage (3x 400 VAC to 480 VAC $\pm 10\%$) is not applied, the voltage is generated at the 24 VDC output from the ACOPOS servo drive's 24 VDC supply voltage; in this case, it is between the maximum permissible and minimum permissible (reduced by max. 2.5 V) 24 VDC supply voltage of the ACOPOS servo drive.
- 7) Valid in the following conditions: 400 VAC mains input voltage, nominal switching frequency, 40°C ambient temperature, installation elevation <500 m above sea level.
- 8) Value for the nominal switching frequency.
- 9) For a mains input voltage of 480 VAC and a switching frequency of 20 kHz, a maximum continuous current of 95 A_{eff} is permitted. At ambient temperatures >10°C, a reduction of the continuous current of 1.65 A_{eff} per °C must be taken into consideration.
- 10) If necessary, the stress of the motor isolation system can be reduced by an additional externally wired dv/dt choke. For example, the RWK 305 three-phase dv/dt choke from Schaffner (www.schaffner.com) can be used. Important: Even when using a dv/dt choke, it is necessary to ensure that an EMC-compatible, low inductance shield connection is used!
- 11) The module's electrical output frequency (SCTRL_SPEED_ACT * MOTOR_POLEPAIRS) is monitored to protect against dual use in accordance with EC regulation 428/2009 | 3A225. If the electrical output frequency of the module exceeds the limit value of 598 Hz uninterrupted for more than 0.5 s, then the current movement is aborted and error 6060 is output (Power element: Limit speed exceeded).
- 12) Continuous power refers to the maximum braking power the ACOPOS servo drive can exchange continuously. Depending on the application, the actual continuous power provided by the external braking resistor is limited by the rated current of fuse I_b (integrated in the ACOPOS servo drive), and the value of the external braking resistance R_{BR}.
- 13) OSSD (output signal switching device) signals are used to monitor signal lines for short circuits and cross faults.
- 14) Continuous operation of ACOPOS servo drives at elevations ranging from 500 m to 2000 m above sea level is possible (taking the specified continuous current reductions into consideration).
- 15) Continuous operation of ACOPOS servo drives at ambient temperatures ranging from 40°C to max. 55°C is possible (taking the specified continuous current reductions into consideration), but this will result in a shorter service life.

4 Status indicators

ACOPOS servo drives are equipped with three LEDs for direct diagnostics:

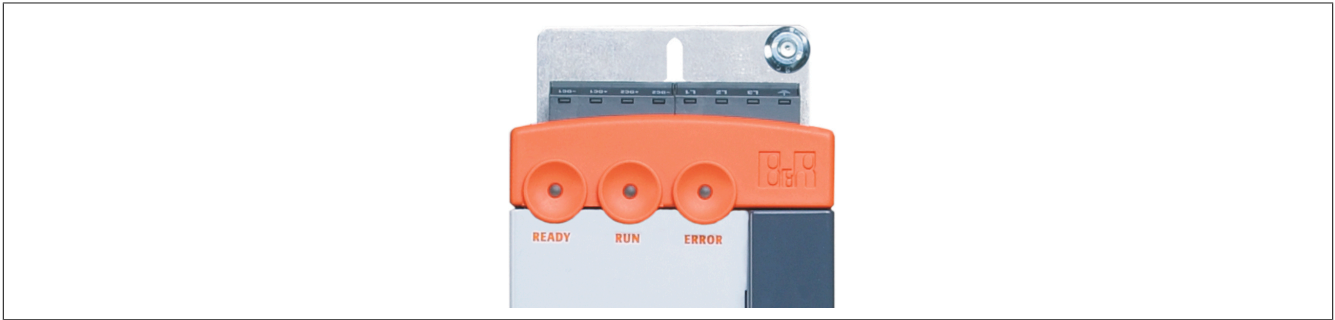


Figure 1: ACOPOS servo drive indicators

LED status indicators

Label	Color	Function	Description	
READY	Green	Ready	Solid green	The module is operational and the power stage can be enabled (operating system present and booted, no permanent or temporary errors).
			Blinking green ¹⁾	The module is not ready for operation. <u>Examples:</u> <ul style="list-style-type: none"> No signal on one or both enable inputs DC bus voltage outside the tolerance range Overtemperature on the motor (temperature sensor) Motor feedback not connected or defective Motor temperature sensor not connected or defective Overtemperature on the module (IGBT junction, heat sink, etc.) Disturbance on network
RUN	Orange	Run	Solid orange	The module's power stage is enabled.
ERROR	Red	Error	Solid red ¹⁾	There is a permanent error on the module. <u>Examples:</u> <ul style="list-style-type: none"> Permanent overcurrent Invalid data in EPROM

Table 3: ACOPOS servo drive - LED status indicators

1) Firmware V2.130 and later.

If no LED is lit up, the ACOPOS servo drive is not supplied with 24 VDC mains voltage.

Danger!

After switching off the device, wait for the DC bus to discharge for at least five minutes. To avoid a hazard, the current voltage on the DC bus must be measured with a suitable measuring instrument and less than 42 VDC before starting work. An unlit operating LED does not indicate that the device is de-energized!

4.1 Status changes when starting up the operating system loader

The following intervals are used for the LED status indicators:

Width of box: 125 ms

Repeats after: 3000 ms

Status	LED	Display
1. Boot procedure for base hardware active	Green	[Green box]
	Orange	[Orange box]
	Red	[Red box]
2. Network plug-in module configuration active	Green	[Green box]
	Orange	[Orange box]
	Red	[Red box]
3. Waiting for network telegram	Green	[Green box]
	Orange	[Orange box]
	Red	[Red box]
4. Network communication active	Green	[Green box]
	Orange	[Orange box]
	Red	[Red box]

Table 4: Status changes when starting up the operating system loader

Error status with reference to CAN plug-in module AC110

Status	LED	Display																							
Invalid hardware ID ¹⁾	Green																								
	Orange																								
	Red	■	■	■	■	■	■	■	■	■	■	■	■	■	■	■	■	■	■	■	■	■	■	■	■
Boot error in CAN base hardware	Green																								
	Orange																								
	Red	■	■	■	■	■	■	■	■	■	■	■	■	■	■	■	■	■	■	■	■	■	■	■	
Bus off	Green																								
	Orange																								
	Red	■	■	■	■	■	■	■	■	■	■	■	■	■	■	■	■	■	■	■	■	■	■	■	
The CAN station number is 0.	Green																								
	Orange																								
	Red	■	■	■	■	■	■	■	■	■	■	■	■	■	■	■	■	■	■	■	■	■	■	■	

Table 5: Error status with reference to CAN plug-in module AC110

- 1) Possible errors:
- The ACOPOS servo drive is defective.
 - The plug-in module is defective
 - The plug-in module is not connected properly in the slot.

Error status with reference to POWERLINK V2 plug-in module AC114

Status	LED	Display																							
Invalid hardware ID ¹⁾	Green	■	■	■	■	■	■	■	■	■	■	■	■	■	■	■	■	■	■	■	■	■	■	■	
	Orange																								
	Red	■	■	■	■	■	■	■	■	■	■	■	■	■	■	■	■	■	■	■	■	■	■	■	
Boot error in POWERLINK base hardware	Green	■	■	■	■	■	■	■	■	■	■	■	■	■	■	■	■	■	■	■	■	■	■	■	
	Orange																								
	Red	■	■	■	■	■	■	■	■	■	■	■	■	■	■	■	■	■	■	■	■	■	■	■	
Error booting the AC114-ARM	Green	■	■	■	■	■	■	■	■	■	■	■	■	■	■	■	■	■	■	■	■	■	■	■	
	Orange																								
	Red	■	■	■	■	■	■	■	■	■	■	■	■	■	■	■	■	■	■	■	■	■	■	■	
The POWERLINK station number is 0.	Green	■	■	■	■	■	■	■	■	■	■	■	■	■	■	■	■	■	■	■	■	■	■	■	
	Orange																								
	Red	■	■	■	■	■	■	■	■	■	■	■	■	■	■	■	■	■	■	■	■	■	■	■	

Table 6: Error status with reference to POWERLINK V2 plug-in module AC114

- 1) Possible errors:
- The ACOPOS servo drive is defective (plug-in module not detected).
 - The plug-in module is defective
 - The plug-in module is not connected properly in the slot.
 - The plug-in module works but is not automatically detected by the ACOPOS servo drive (old bootstrap loader).

5 Dimension diagram and installation dimensions

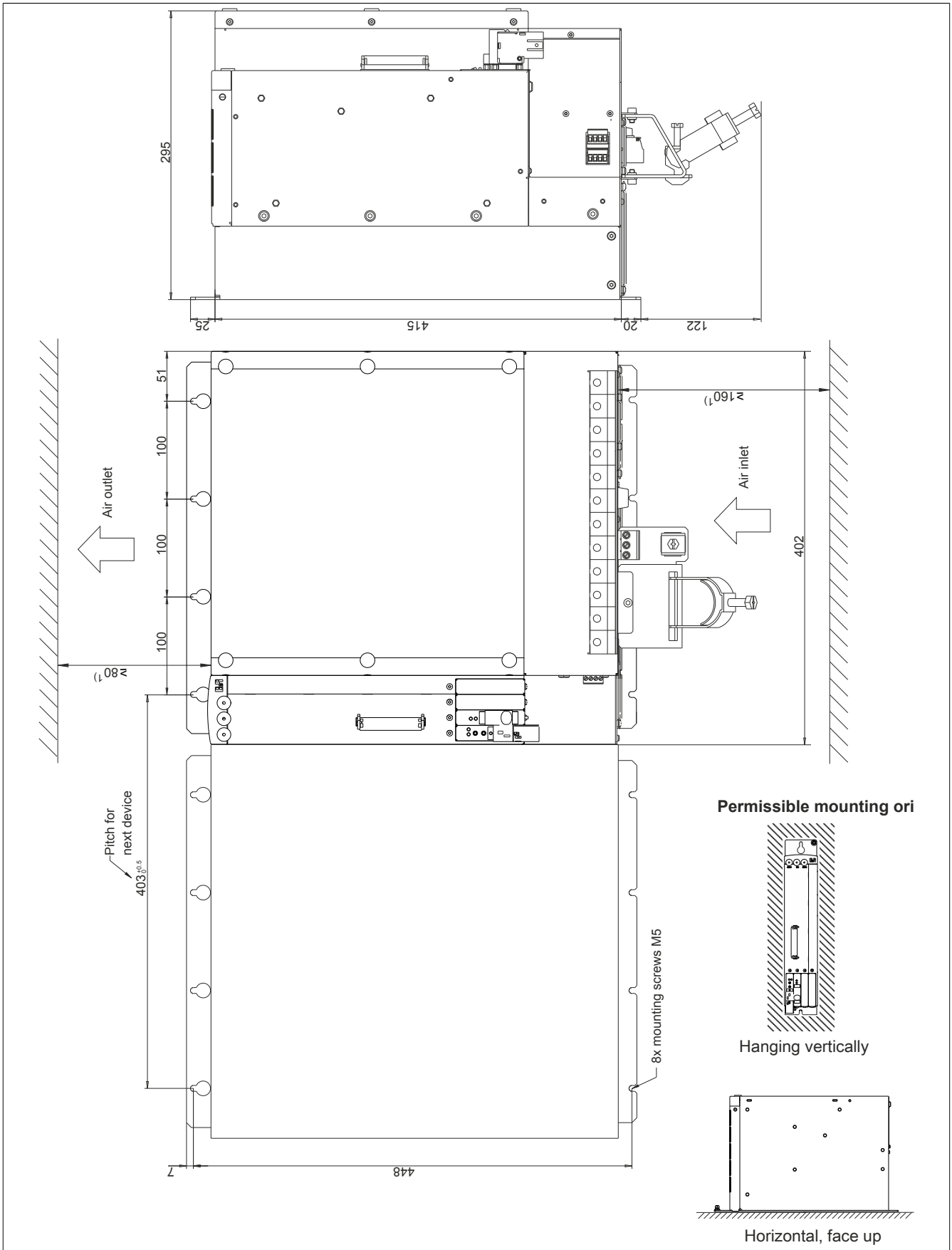


Figure 2: Dimension diagram and installation dimensions

- 1) For sufficient air circulation, a clearance of at least 80 mm must be provided above and below the ACOPOS servo drive. Approx. 160 mm free space is required under the ACOPOS servo drive to prevent cabling problems.

6 Wiring

Pinout overview

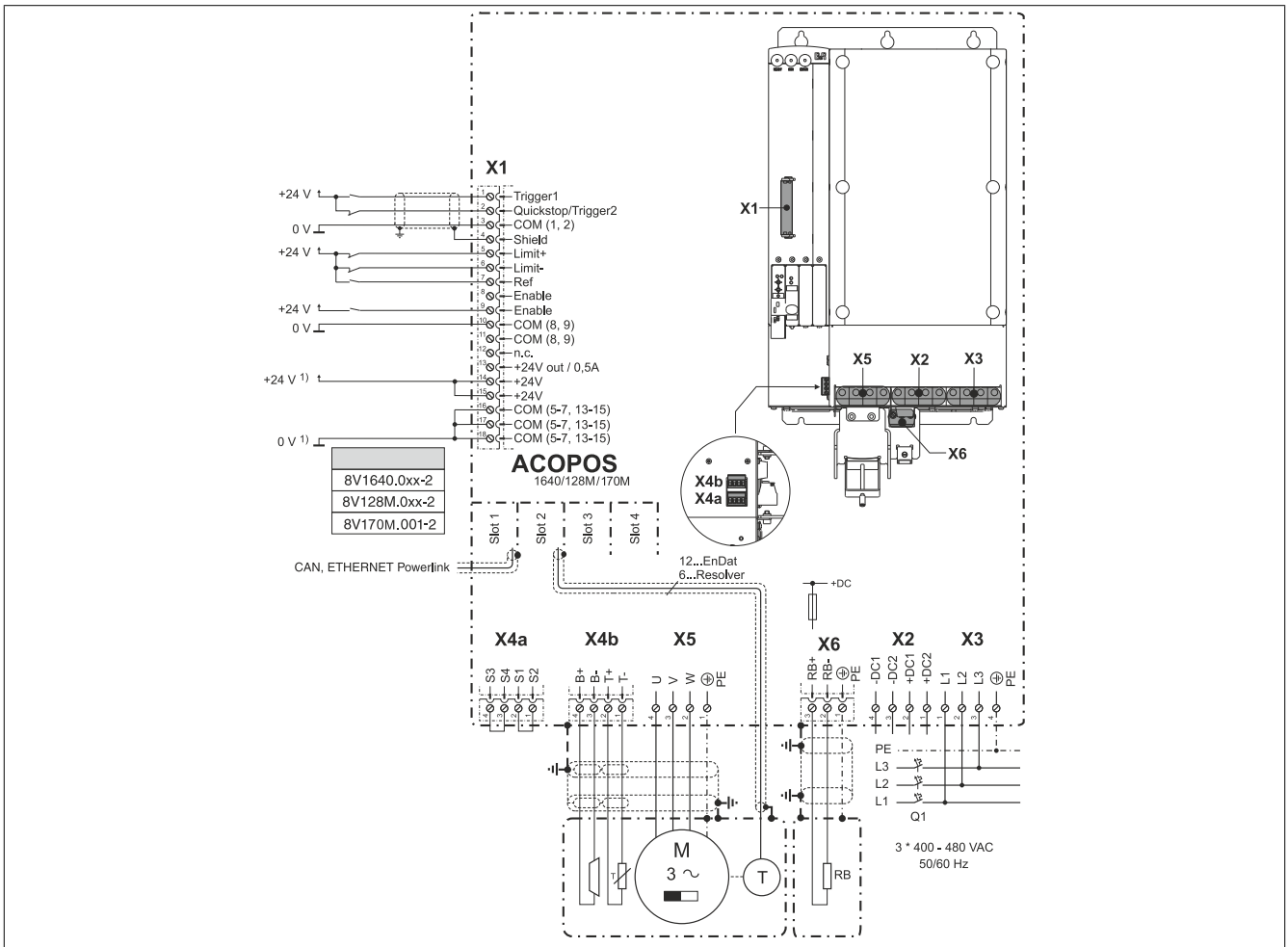


Figure 3: ACOPOS 1640, 128M - Pinout overview

- 1) When using an external 24 VDC supply for the ACOPOS 1640 and 128M servo drives, both +24 VDC connections (X1/14, X1/15) and at least two of the three COM connections (X1/16, X1/17, X1/18) must always be wired so that the individual terminals are not overloaded.

6.1 X1 - Pinout


X1	Pin	Description	Function
	1	Trigger1	Trigger 1
	2	Quickstop / Trigger 2	Quickstop / Trigger 2
	3	COM (1, 2)	Trigger 1, quickstop / Trigger 2 0 V
	4	Shield	Shield
	5	Limit+	Positive hardware end position
	6	Limit-	Negative hardware end position
	7	Ref	Reference switch
	8	Enable ¹⁾	Enable
	9	Enable ¹⁾	Enable
	10	COM (8, 9)	Enable 0 V
	11	COM (8, 9)	Enable 0 V
	12	---	---
	13	+24 V out / 0.5 A	+24 V output / 0.5 A
	14	+24 V	+24 V power supply ²⁾
	15	+24 V	+24 V power supply ²⁾
	16	COM (5-7, 13-15)	0 V power supply ²⁾
	17	COM (5-7, 13-15)	0 V power supply ²⁾
	18	COM (5-7, 13-15)	0 V power supply ²⁾
The following connections are connected internally in the device: <ul style="list-style-type: none"> • Pin 8 → Pin 9 (enable) • Pin 10 → Pin 11 (enable 0 V) • Pin 14 → Pin 15 (power supply +24 V) • Pin 16 → Pin 17 → Pin 18 (power supply 0 V) 			

Table 7: X1 - Pinout

- 1) Wiring is not permitted to exceed a total length of 30 m.
- 2) When using an external 24 VDC supply for the ACOPOS 1640 and 128M servo drives, both +24 VDC connections (X1/14, X1/15) and at least two of the three COM connections (X1/16, X1/17, X1/18) must always be wired so that the individual terminals are not overloaded.

Information:

To obtain a defined reference of ground to ground potential, B&R recommends grounding the COM connections (5-7, 13-15) on connector X1.

6.2 X2 - Pinout

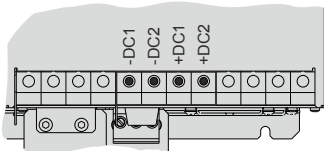
X2	Description	Function
	-DC1	U DC bus -
	-DC2	U DC bus -
	+DC1	U DC bus +
	+DC2	U DC bus +

Table 8: X2 - Pinout

6.3 X3 - Pinout

Danger!

Servo drives are not permitted to be operated directly on IT power systems and corner-grounded TN-S power systems with protective ground conductor!

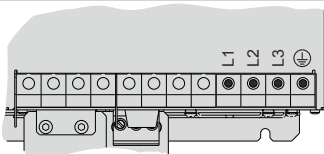
X3	Description	Function
	L1	Mains connection L1
	L2	Mains connection L2
	L3	Mains connection L3
	⊕	Protective ground conductor

Table 9: X3 - Pinout

6.4 X4a, X4b - Pinout

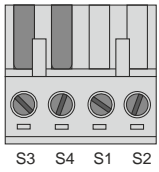
X4a	Pin	Description	Function
	1	S2 ¹⁾	Enabling, power supply of external holding brake (+)
	2	S1 ¹⁾	Enabling of external holding brake (+)
	3	S4	Enabling, power supply of external holding brake (-)
	4	S3	Enabling of external holding brake (-)

Table 10: X4a - Pinout

- 1) If the holding brake is connected via an additional external relay contact (ground-in e.g. via connections S1/S2) instead of only via the internal transistor, then the internal quenching circuit has no effect! In this case, the customer must make sure that neither the relay contact nor the braking coil are damaged when switching off the brake. This can be done by interconnecting the coil or - better still - interconnecting the contact with a quenching circuit.

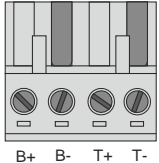
X4b	Pin	Description	Function
	1	T-	Temperature sensor -
	2	T+	Temperature sensor +
	3	B- ¹⁾	Brake -
	4	B+ ¹⁾	Brake +

Table 11: X4b - Pinout

- 1) If the holding brake is connected via an additional external relay contact (ground-in e.g. via connections S1/S2) instead of only via the internal transistor, then the internal quenching circuit has no effect! In this case, the customer must make sure that neither the relay contact nor the braking coil are damaged when switching off the brake. This can be done by interconnecting the coil or - better still - interconnecting the contact with a quenching circuit.

Danger!

The connections for the motor temperature sensors and the motor holding brake are safely isolated circuits. These connections are therefore only permitted to be connected to devices or components that have sufficient isolation per IEC 60364-4-41 or EN 61800-5-1.

Caution!

If B+ and B- are swapped when connecting the permanent magnet holding brakes, then the brakes cannot be opened! ACOPOS servo drives cannot determine if a holding brake is connected with reverse polarity!

6.4.1 Wiring the connections for the motor holding brake

The power supply, enabling and monitoring of the output for the motor holding brake can be carried out in three different ways via the wiring of connector X4a:

	Figure	Description
1		<ul style="list-style-type: none"> • Power supply: Internal via the ACOPOS servo drive • Enabling: Internal via the ACOPOS servo drive • Monitoring: Internal via the ACOPOS servo drive <p>Jumpers must be placed between connections S1 and S2 as well as S3 and S4 on connector X4a. ¹⁾</p>
2		<ul style="list-style-type: none"> • Power supply: Internal via the ACOPOS servo drive • Enabling: Possible internally by the ACOPOS servo drive and externally by dry contacts ²⁾ • Monitoring: Internal via the ACOPOS servo drive <p>Information: ACOPOS-internal monitoring must be configured according to the requirements of the application. ³⁾</p>
3		<ul style="list-style-type: none"> • Power supply: External • Enabling: External • Monitoring: External <p>Information: ACOPOS-internal monitoring cannot be used here; it must therefore be disabled using software. ⁴⁾</p>

Table 12: Enabling the external holding brake

- 1) The two jumpers are already wired on connector X4a supplied with ACOPOS servo drives.
- 2) External dry contacts can be connected between S1 and S2 and between S3 and S4. This makes it possible to enable the holding brake via external safety circuits independently of the control integrated in the ACOPOS servo drive.
- 3) Configuration takes place using ParID 90 (1 ... Internal monitoring active, 5 ... Internal monitoring not active).
- 4) Disabling takes place using ParID 90 (5 ... Internal monitoring not active).

6.5 X5 - Pinout

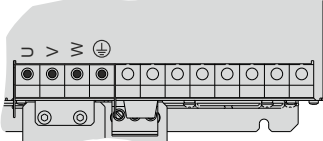
X5	Description	Function
	U	Motor connection U
	V	Motor connection V
	W	Motor connection W
	⊕	Protective ground conductor

Table 13: X5 - Pinout

6.6 X6 - Pinout

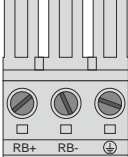
X6	Pin	Description	Function
	1	PE	Protective ground conductor
	2	RB-	Braking resistor -
	3	RB+	Braking resistor +

Table 14: X6 - Pinout

6.7 Input/Output circuit diagram

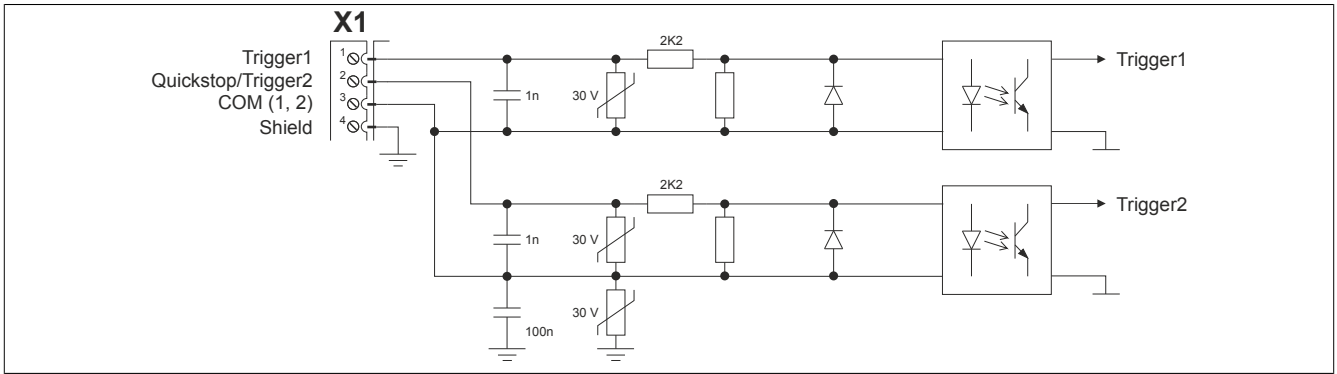


Figure 4: Trigger

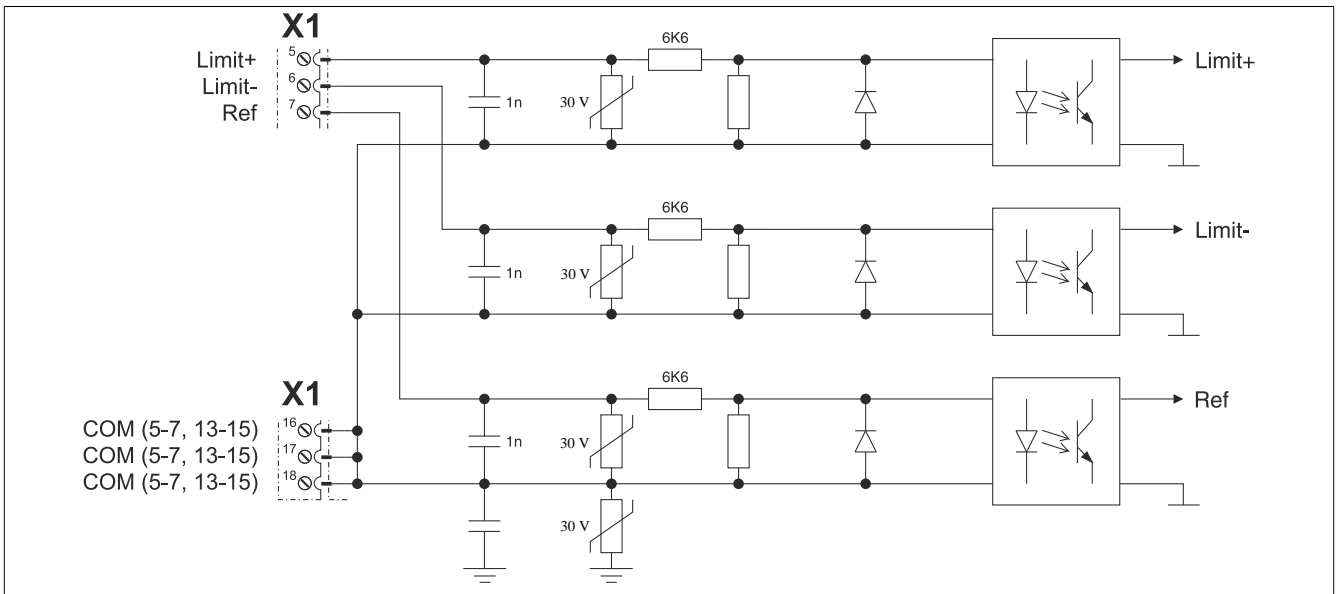


Figure 5: Limit

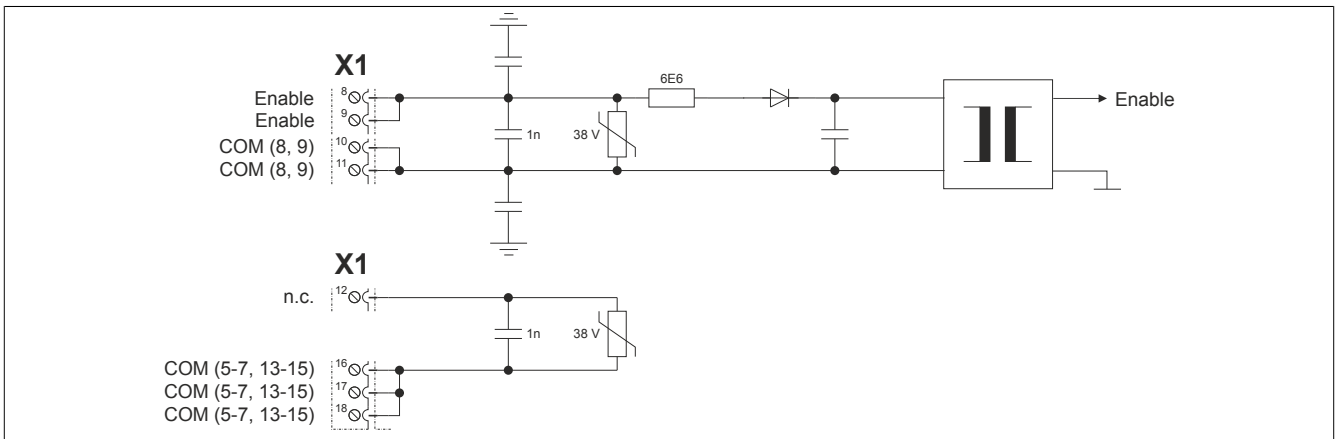


Figure 6: Enable

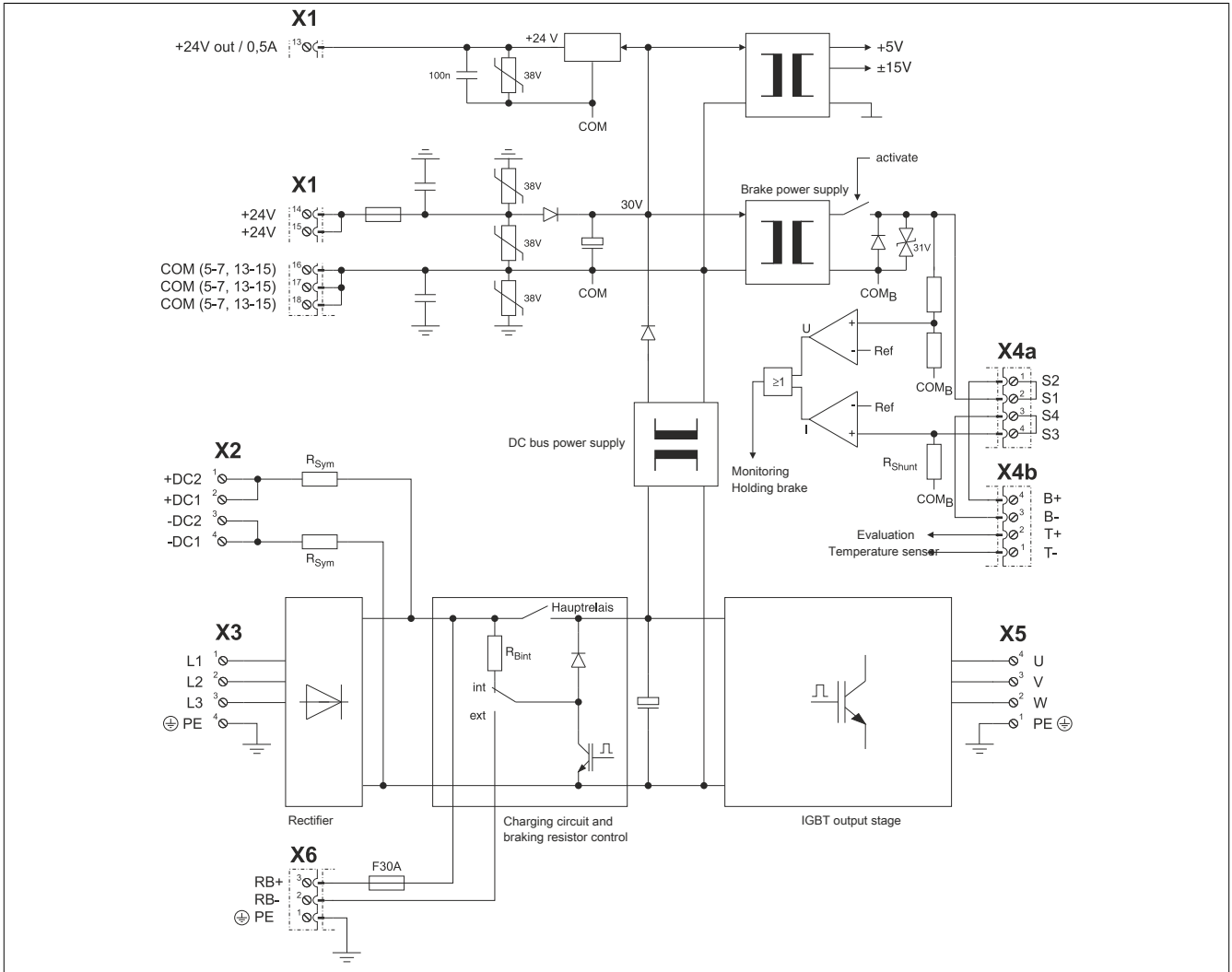


Figure 7: ACOPOS 1640, 128M - Input/Output circuit diagram