

## PCD1/ PCD2 Series

<b>0</b>	<b>Contents</b>	
0.2	Brands and trademarks .....	0-7
<b>1</b>	<b>Graphical index</b>	
1.1	PCD1.M110/M120/M130/M125/M135 .....	1-1
1.2	PCD2.M110/M120/M150.....	1-2
1.3	PCD2.M170 .....	1-3
1.4	PCD2.M480 .....	1-4
<b>2</b>	<b>Guidance</b>	
2.1	Introduction .....	2-1
2.2	Planning an application with PCD1/2/3 components .....	2-2
2.3	Cabling.....	2-4
2.3.1	Cable routing.....	2-4
<b>3</b>	<b>Saia PCD® Classic CPUs and expansion housings</b>	
3.1	System overview.....	3-1
3.1.1	Outphased Saia PCD®s.....	3-1
3.1.2	Saia PCD® Web-Server.....	3-1
3.2	General technical details.....	3-2
3.3	System resources .....	3-4
3.3.1	Program blocks .....	3-4
3.3.2	Computation ranges for count types .....	3-4
3.3.3	Media.....	3-5
3.3.4	Program structure for the Saia PCD® Classic family .....	3-6
3.4	CPU overview .....	3-7
3.4.1	PCD1.M1xx .....	3-7
3.4.2	Block diagram : PCD1.M1xx .....	3-8
3.4.3	Hardware and firmware versions for the PCD1.....	3-9
3.4.4	Firmware Upgrade for the PCD1.M110, PCD1.M120 and PCD1.M130.....	3-10
3.4.5	Firmware Upgrade for the PCD1.M125 and PCD1.M135 .....	3-10
3.4.6	PCD2.M1x0/M480 Hardware and Firmware .....	3-11
3.4.7	Block diagram : PCD2.Mxx0 .....	3-14
3.4.8	Hardware and firmware versions for the PCD2.M110/M120 .....	3-16
3.4.9	Hardware and firmware versions for the PCD2.M150, FW < V0D0 (until early 2007) .....	3-16
3.4.10	Hardware and firmware versions for the PCD2.M150, FW ≥ V0D0 (since early 2007) .....	3-17
3.4.10	Hardware and firmware versions for the PCD2.M170/M480.....	3-17
3.5	Mounting .....	3-18
3.5.1	Mounting position and ambient temperature .....	3-18
3.6	Expansion housings and bus cables.....	3-19
3.6.1	Expansion with PCD2 components.....	3-20
3.6.2	Expansion with PCD3 components.....	3-22
3.6.3	Expansion with PCD4 components.....	3-23

3.7	Installation and addressing of PCD2 I/O modules .....	3-24
3.7.1	Insertion of I/O modules .....	3-24
3.7.2	Address and terminal designation .....	3-24
3.7.3	Cable layout .....	3-25
3.8	Dimensions .....	3-26
3.9	Power supply and connection plan .....	3-27
3.9.1	External power supply .....	3-27
3.9.2	Earthing and connection plan.....	3-28
3.9.3	Internal power supply .....	3-30
3.9.4	Capacity of internal power supply .....	3-30
3.10	PCD1.M1x0 and PCD1.M1x5 operating states.....	3-31
3.11	PCD2.M1x0/M480 operating states .....	3-32
3.12	Pin Configuration PCD1 .....	3-33
3.13	Pin Configuration PCD2 .....	3-34
3.14	Expansion of user memory .....	3-35
3.14.1	Basics.....	3-35
3.14.2	Memory location of the user program, the resources, texts and DBs .....	3-35
3.14.3	Example of a memory configuration.....	3-35
3.14.4	PCD1.M1x0 .....	3-38
3.14.5	PCD1.M125 and PCD1.M135 .....	3-40
3.14.6	PCD2.M110/M120/M150 .....	3-42
3.15	Partitioning options for user memory .....	3-45
3.16	Data storage in case of power outage .....	3-46
3.17	Backup of the user program (flash card for PCD2.M170/M480).....	3-47
3.17.1	General.....	3-47
3.17.2	Copying the application to the flash card (backup) .....	3-48
3.17.4	Backup/restore of RAM texts/DBs at run-time.....	3-50
3.18	Hardware clock (Real Time Clock).....	3-55
3.18.1	Clock module PCD2.F500 (obsolete, PCD2.M110/M120 only).....	3-55
3.19	Monitoring the CPU (watchdog).....	3-56
3.19.1	PCD1 hardware watchdog .....	3-56
3.19.2	PCD2 hardware watchdog .....	3-57
3.19.3	Software watchdog for PCD1 and PCD2 .....	3-59
3.20	Internal LED displays and small terminals .....	3-60
3.20.1	Outphased displays and small terminals .....	3-60
3.20.2	PCD2.F510 7-segment LED display (PCD2.M110/M120/M150 only) .....	3-60
3.20.3	PCD2.F530 7-Segment LED display (PCD2.M120/M150 only) .....	3-62
3.20.4	PCD7.D16x Small terminal kits .....	3-63
3.21	Interrupt inputs .....	3-64
3.21.1	Basics.....	3-64
3.21.2	PCD1.M120/M130 and PCD1.M125/M135 .....	3-64
3.21.3	PCD2.M120/M150/M170 .....	3-65
3.21.4	PCD2.M480.....	3-65
3.22	Run/Stop or Run/Halt switch (PCD2.M170/M480 only) .....	3-67
3.23	HALT switch on PCD1.M125 and PCD1.M135 .....	3-68
3.23.1	HALT switch on PCD1.M125 and PCD1.M135 as input.....	3-68
3.24	Storing data in EEPROM .....	3-69
3.25	Resetting the outputs on STOP or HALT (PCD2 only).....	3-70

3.26	Presence/voltage monitoring for expansion unit (PCD2 only) .....	3-71
------	--	------

#### 4 Saia PCD® Classic communication interfaces

4.1	General informations .....	4-1
4.1.1	Outphased interface modules .....	4-1
4.1.2	SBCS-Net .....	4-2
4.2	Summary of PCD1/PCD2 onboard interfaces .....	4-3
4.3	Summary of PCD1 plug-in interface modules.....	4-4
4.4	Summary of PCD2 plug-in interface modules.....	4-5
4.5	Onboard interfaces .....	4-6
4.5.1	PGU connection (PORT#0, PCD1 and PCD2) (RS-232) for connecting programming devices .....	4-6
4.5.2	PGU connection (PORT#0, PCD1 and PCD2) (RS-232) as communication interface.....	4-7
4.5.3	PGU connection (PORT#0, only on PCD2.M1x0) (RS-485) as communication interface.....	4-8
4.5.4	RS-485 communication interface PORT#1, only on PCD1.M110.....	4-9
4.5.5	RS-485 communication interface PORT#6, only on PCD2.M480 .....	4-10
4.5.6	USB interface as PGU interface. on PCD2.M480 .....	4-11
4.5.7	Profi S-Net on PCD2.M480 .....	4-12
4.6	Plug-in interfaces modules: Socket A.....	4-13
4.6.1	RS-485/422 with PCD7.F110, Port#1 (with PCD1.M110 hard-wired) .....	4-13
4.6.2	RS-232 with PCD7.F120 (suitable for modem), Port#1 (without PCD1.M110) .....	4-15
4.6.3	RS-232 with PCD7.F121, Port#1 (without PCD1.M110).....	4-16
4.6.4	Current loop with PCD7.F130, Port#1 (without PCD1.M110) .....	4-17
4.6.5	RS-485 with PCD7.F150, Port#1 (without PCD1.M110).....	4-19
4.6.6	MP-Bus with PCD7.F180, Port#1 (without PCD1.M110) .....	4-20
4.6.7	Modem communication .....	4-22
4.7	Serial interfaces: socket B(1) or B2 .....	4-23
4.7.1	RS-485 with PCD2.F520 (PCD2 only) .....	4-23
4.7.2	RS-422 with PCD2.F520 .....	4-25
4.7.3	RS-232 with PCD2.F520/F522 .....	4-27
4.7.4	RS-232 full with PCD2.F522 (suitable for modem) .....	4-30
4.8	Ethernet TCP/IP .....	4-32
4.9	Profibus.....	4-33
4.9.1	Profibus DP Master, module PCD7.F750.....	4-34
4.9.2	Profibus DP Slave, module PCD7.F77x.....	4-36
4.9.4	Profibus FMS, module PCD7.F700 .....	4-38
4.10	LONWORKS® (freely configurable LON nodes) .....	4-40

4.11	Connection module for MP-Bus PCD2.T500 .....	4-42
4.11.1	Communications signals .....	4-42
4.11.2	Controls on PCD2.T500 .....	4-42
4.11.3	Connection and wiring .....	4-43
4.11.4	Supply possibilities .....	4-44
4.11.5	Configuration examples .....	4-45
4.11.6	Communications times for MP-Bus .....	4-46
4.11.7	Calculation of line length .....	4-46
4.11.8	Maximum line length for 24 VAC supply .....	4-47
4.11.9	Maximum line length for 24 VDC supply .....	4-47
4.11.10	Maximum line length for 24 VAC supply (in situ) .....	4-48
<b>5</b>	<b>Input/output (I/O) modules</b>	
<b>6</b>	<b>System cables and adapters</b>	
6.1	System cables with I/O module connections to the Saia PCD® .....	6-1
<b>7</b>	<b>Maintenance</b>	
7.1	Changing the battery on the PCD1.M13x and PCD2.Mxxx CPUs .....	7-1
7.2	Updating firmware .....	7-3
7.2.1	Updating firmware on the PCD2.M110/M120 .....	7-3
7.2.2	Updating firmware on the PCD2.M150 .....	7-3
7.2.3	Updating firmware on the PCD1.M1x5, PCD2.M170 and PCD2.M480 .....	7-3
<b>A</b>	<b>Appendix</b>	
A.1	Icons .....	A-1
A.2	Definitions of serial interfaces .....	A-2
A.2.1	RS-232 .....	A-2
A.2.3	TTY/current loop .....	A-4
A.3	Protocols on serial ports .....	A-5
A.3.1	Protocols supported by the firmware .....	A-5
A.3.2	Protocols implemented in the user program .....	A-5
A.4	Order codes .....	A-6
A.5	Contact .....	A-11



## 0.1 Document History

0

Date	Version	Changes	Remarks
EN11a	2004-12-24	Whole Doc. Chapt. 4.8.1 Page 57	- translation from D11 - error in Profibus: 4.8.1 new - error in formulas: Page 57
EN12	2005-02-01	Chapt. 0 Chapt. 1 Chapt. 3	- error in index (Acrobat) - error in graphical index M480 - watch-Dog IL-Example.: new
EN13	2005-10-11	Chapt. 5	- corrected error in pin allocation PCD2.A465
EN14	2007-07-25	Chapt. 3 Chapt. 4  Chapt. 5       Chapt. A	- inserted new controllers PCD1.M1x5 - added communication modules PCD7.F121 and PCD2.T500 - new order for the I/O-modules, according to the price list - maximal current of the I/O-modules instead of typical current. - added new I/O-Modules PCD2.E112, PCD2.E116, PCD2.E613, PCD2.E616 - PCD2.A465 pinout corrected - new TIP by PCD2.W2x0, wrong polarity on input - description of the Jumper positions for PCD2.K525 - calculation of the spark deletion in the appendix
EN15	2008-07-22	Chapt. 5 Chapt. 5	- Added new module PCD2.W525 - «Definition of input signals» revised
EN16	2008-12-17	Chapt. 3.4 Chapt. 5.7 Chapt. 5.12.1 Chapt. 6 Chapt. 7.1	- PCD2.M150 now with FW update - Wiring PCD2.W2x0 corrected - Digital / analog values PCD2.W2x0 corrected - New in its own handbook 26/792 - New indication for battery change
EN17	2009-12-15	all	Conversion in CS4 and error correction
EN18	2010-02-15	Chapt. 3	New chapt. 3.12/3.13
EN19	2011-01-05	Chapt. 4	PCD7.F121 for all CPU types other than PCD1.M110
EN20	2011-06-01  2011-11-23	Chapt. 3 -5  Chapt. 4.1.2. Chapt. 3-19	- External and 24V power supply of the modules, PGND assignments Use of SBC S-Bus Correction HW watchdog error.
EN21	2012-03-29  2012-06-20	Chapt. 3 Chapt. 5.2.1 Chapt.3	Minimal storage temperature -20 °C → -25 °C PCD2.E112 not PCD2.E113 User memory HW version <H
EN22	2013-04-23 2013-11-26	Chapt. 4 -	- internal wiring PCD2.K111 - new logo and new company name
EN23	2014-07-22	Chapt. 5.2.3	Changed wrong connection diagramm
EN24	2014-07-30	Chapt. 5	Chapter 5 outsourced to doc.: 27-600

## 0.2 Brands and trademarks

0

Saia PCD® and Saia PG5®  
are registered trademarks of Saia-Burgess Controls AG.

Technical modifications are based on the current state-of-the-art technology.

Saia-Burgess Controls AG, 2003 © All rights reserved.

Published in Switzerland



# 1 Graphical index

The graphical index singles out some highlights from the Hardware manual for the PCD1/PCD2 Series, and allows you to click on a component/connector to jump straight to the corresponding section. The facility to jump to any section from the table of contents is still to be completed.

1

## 1.1 PCD1.M110/M120/M130/M125/M135



1.2 PCD2.M110/M120/M150

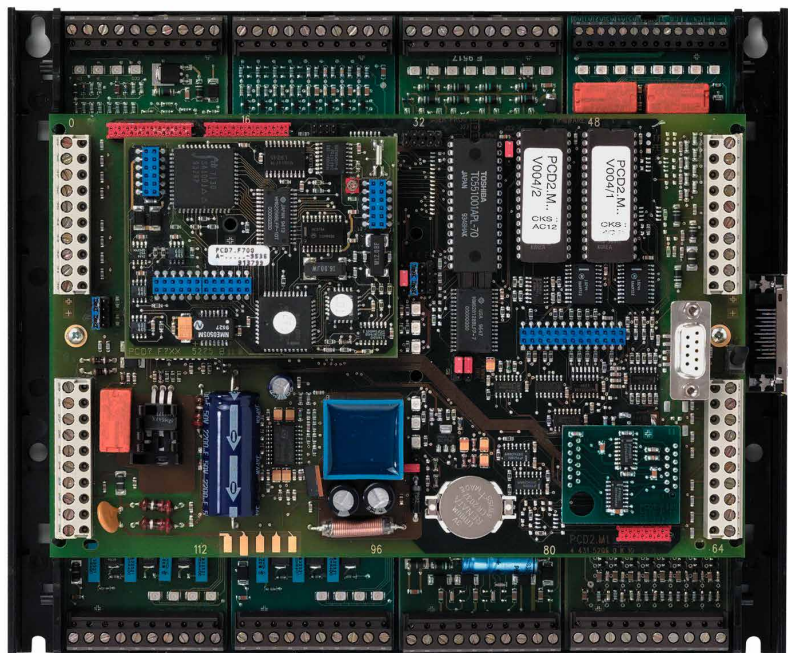
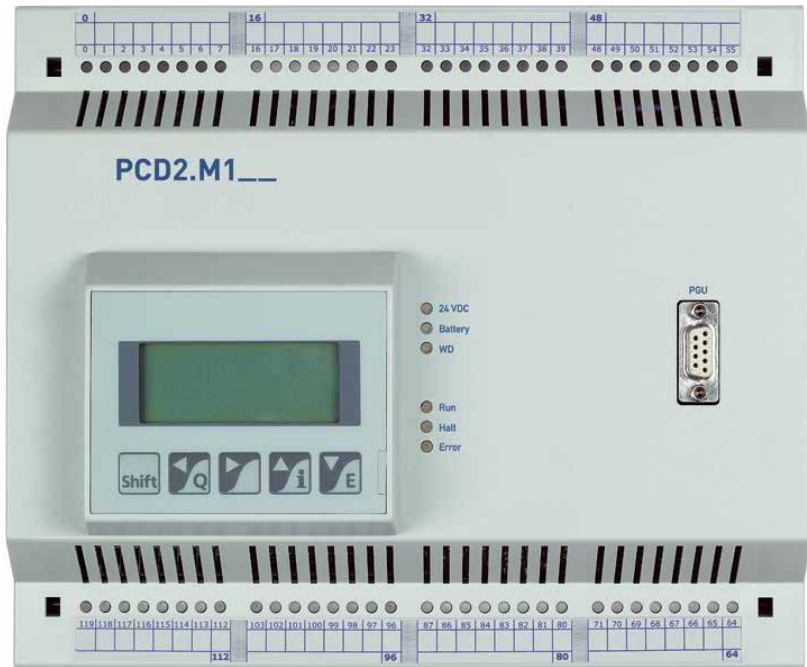

1.3 PCD2.M170

1

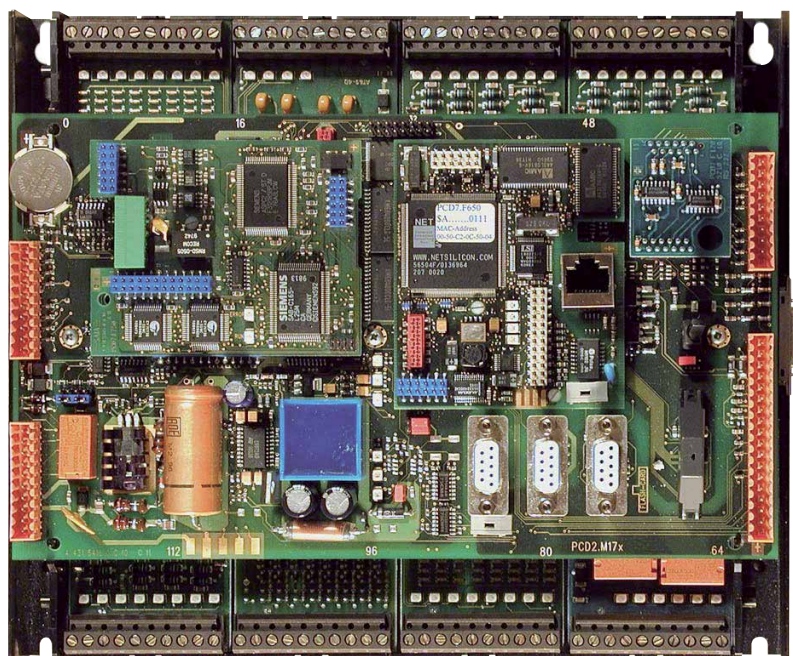
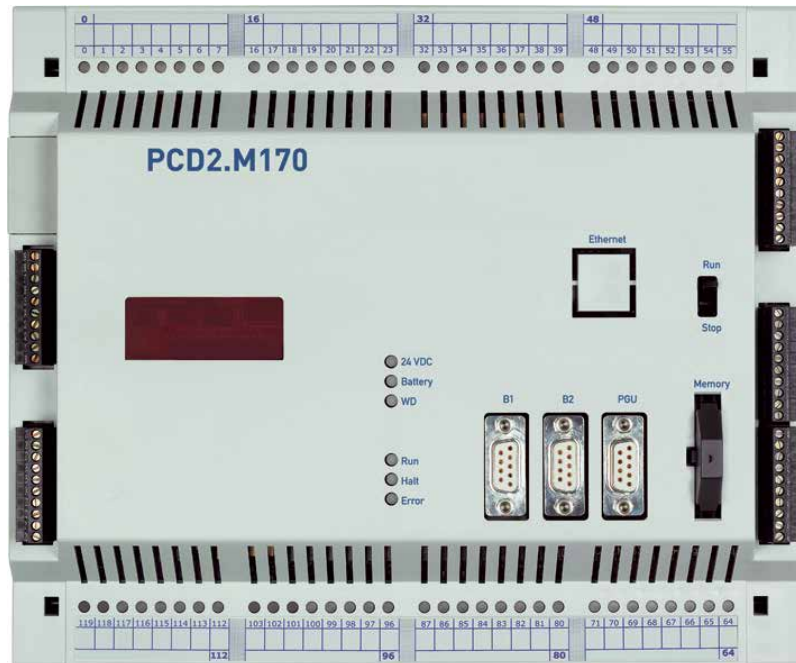

1.4 PCD2.M480

1

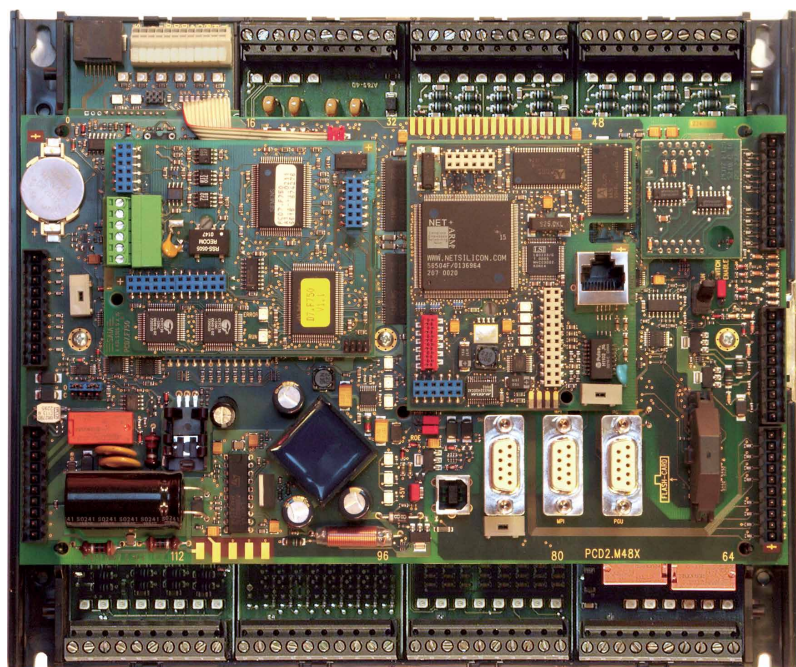
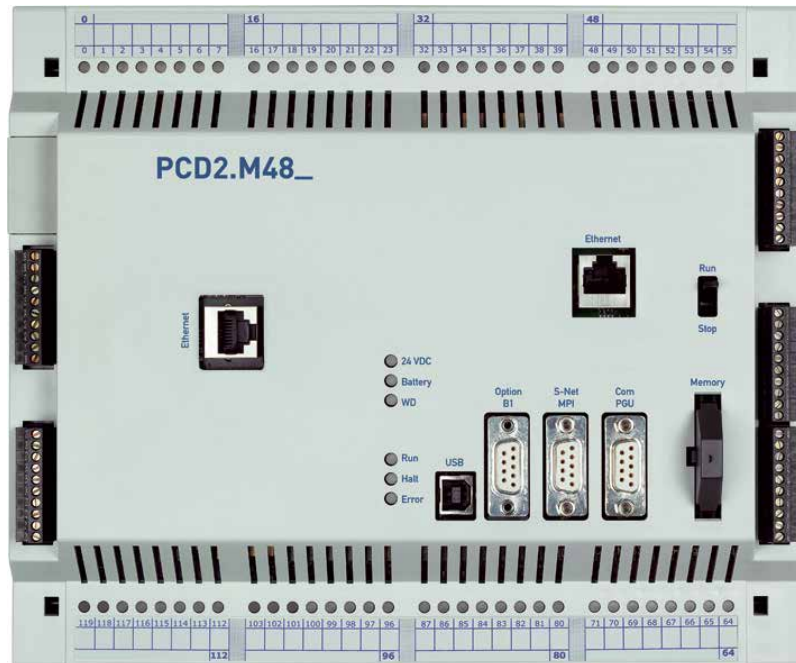

## 2 Guidance

### 2.1 Introduction

This manual covers the technical aspects of the PCD1 and PCD2 components. The following terms are used frequently:

- CPU Central processing unit: the heart of the Saia PCD®
- RIOs Remote I/Os: inputs and outputs connected to the CPU via a field bus such as Profibus
- LIOs Local I/Os: these are connected to the CPU via the I/O bus or a RIO (i.e. with the shortest possible cables)
- Modules Input/output elements, mounted in a housing, matched to the PCD1/2 system
- Module holders CPUs, RIOs or LIOs, to which modules may be attached

The aim of the Overview section is to present the essentials of planning and installing control systems with PCD1/2 components. It covers the following topics:

- [Planning an application](#)
- [Cabling](#)

Details of hardware, software, configuration, maintenance and troubleshooting are described in separate sections.

**2.2 Planning an application with PCD1/2/3 components**

The following aspects should be considered when planning PCD1/2 applications:

- The internal load current taken by the I/O modules from the +5 V and V+ supply must not exceed the maximum supply current specified for the CPUs
- The CPU type determines the maximum number of modules
- The total length of the I/O bus is limited by technical factors; the shorter, the better

**When planning an application, we recommend the following procedure:**

- 1 Select the I/O modules according to requirements.
- 2 Check that the number of modules is allowed:

PCD Type	Max. number of I/O modules				Max. number <sup>1)</sup> of digital I/Os		
	PCD1/PCD2 CPU	PCD2 expansion	PCD3 expansion	Total	PCD1/PCD2 CPU	Expansion	Total
PCD1	4	–	–	4	64	–	64
PCD2.M120/150	8	8	8	16	128	128(-1)	256(-1)
PCD2.M170	8	8	24	32	128	384(-2)	512(-2)
PCD2.M480	8	8	56	64	128	896(-1)	1024(-1)

<sup>1)</sup> PCD2 modules and PCD3 modules with 16 I/Os each



The values in brackets have to be subtracted from the maximum number of digital I/Os because of the watchdog relay.



If you want to expand PCD2 CPUs with PCD3 LIOs/RIOs, please refer to the planning instructions in the PCD3 manual.

If the number of modules is allowed, continue from 3; if not, select a different CPU

- 3 If necessary, select the PCD2 expansion housing:
  - PCD2.C100 with 8 module sockets
  - PCD2.C150 with 4 module sockets
  - PCD2.K100 26-core extension cable for connecting PCD2 base units mounted beneath each other.
  - PCD2.K110 26-core extension cable for connecting PCD2 base units mounted side-by-side.
  - PCD2.K120 26-core extension cable for specific applications (length 2 m).
  - PCD2.K106 26-core extension cable for connecting PCD2 CPUs with PCD3 module holders.
- 4 Where PCD2.Wxxx and PCD2.Hxxx modules are used, calculate the load current from the internal +5 V and V+ supply (use the worst-case / highest values)

- 5 Check that the max. supply current for the CPU is sufficient; it generally should be. In extreme cases, switch to PCD3 expansion units.
- 6 Estimate consumption from the 24 V supply. Use estimated values from the section on “Hardware”.  
These estimated values can be found in section 3.8.5, “Power consumption of PCD2/PCD3 input/output modules”.

2



Note that in most applications the outputs place the heaviest load on the 24 V supply. For 16 outputs with a load current of 0.5 A each, the loading will be 8 A with all outputs connected.

## 2.3 Cabling

### 2.3.1 Cable routing

- 230 V supply lines and signal lines must be laid in separate cables at least 10 cm apart. Even within the switching cabinet, it is advisable to leave space between power and signal lines.
- Digital signal /bus lines and analogue signal /sensor lines should be laid in separate cables
- It is advisable to use shielded cables for analogue signal lines.
- The shield should be earthed at the entry or exit to the switching cabinet. The shields should be as short as possible and of the largest possible cross-section. The central earthing point should be  $> 10 \text{ mm}^2$  and connected to the PE ground wire by the shortest route
- The shield is generally connected to one side of the switching cabinet only, unless there is a potential equalization with significantly lower resistance than the shield resistance
- Inductivities installed in the same switching cabinet, e.g. contactor coils, should be provided with suitable suppressors (RC elements)
- Switching cabinet components with high field intensity, e.g. transformers or frequency inverters, should be shielded with separator plates with a good ground connection.

#### ***Surge protection for long distances or external lines***

- Where lines are laid outside the building, or over longer distances, suitable surge protection measures should be applied. For bus lines in particular, these measures are essential.
- With lines laid outside, the shield must have adequate current-carrying capacity and be earthed at both ends.
- The surge conductors should be installed at the input to the switching cabinet.



### 3 Saia PCD® Classic CPUs and expansion housings



The CPUs in the xx7 Series are described in a separate manual, 26/757.

#### 3.1 System overview

##### 3.1.1 Outphased Saia PCD®s

3

Article	Active	Not recommended for new projects	Outphased (no longer produced)
PCD1.M110		x	
PCD1.M120			x
PCD1.M125	x		
PCD1.M130			x
PCD1.M135	x		
PCD1.M135F655	x		
...			
PCD2.M110	x		
PCD2.M120			x
PCD2.M150	x		
PCD2.M170	x		
PCD2.M170F655	x		
PCD2.M480	x		
PCD2.M480F655-2	x		

##### 3.1.2 Saia PCD® Web-Server

The Saia PCD® controllers PCD1.M125, PCD1.M135, PCD2.M150, PCD2.M170, PCD2.M480 and PCD3.Mxxx0 come with an integrated web server as standard:

- Web browser as a tool for commissioning, support and visualization:  
Access to the SBCWeb server is via standard web browsers such as Internet Explorer or Netscape Navigator. This makes the web browser, which can be operated intuitively by anyone, the standard tool for commissioning, service, support and visualization of machines, units and installations. The user can retrieve pre-defined device and system-specific HTML pages, giving access to all data on controllers and RIOs. Graphical elements (images, diagrams etc.) as well as text documents (operating and repair manuals) can also be integrated into the HTML pages, to provide a personalized user interface
- General access to any desired interfaces and networks:  
Access to the web server is available not only via Ethernet TCP/IP, but also via cost-effective standard serial interfaces (RS-232, RS-485, modem etc.) and via Profibus networks, throughout the system and at different levels in the network. This makes it economical to use web technology to operate and monitor even the smallest applications.
- The Saia PCD® web server is integrated into all products:  
Having a web server integrated as standard eliminates the cost of run-time licenses or additional modules. In the PCD3 controllers enumerated above and the PCD3 RIOs, the web server is already included in the base units, at no extra cost.

### 3.2 General technical details

Supply (external and internal)	
Supply voltage (according EN / IEC 61 131-2)	24 VDC -20 / +25% incl. 5% ripples
Power consumption <sup>1)</sup>	PCD1 and PCD2: typically 625 mA / 15 W for 64 I/Os PCD2: typically 833 mA / 20 W for 128 I/Os
Capacity of internal 5 V bus <sup>2)</sup>	PCD1: 750 mA PCD2.M110/M120 hardware version <H: 1100 mA PCD2.M110/M120 hardware version >=H: 1600 mA PCD2.M150: 1600 mA PCD2.M170: 1600 mA PCD2.M480: 2000 mA
Capacity of internal +V bus (16...24 V) <sup>2)</sup>	PCD1: 100 mA PCD2: 200 mA
Short voltage interruptions (according EN / IEC 61 131-2)	≤ 10 ms with interval ≥ 1 s

1) The loads on the outputs are generally more significant for sizing the supply than the internal power leakage within the controller

2) When planning PCD2 systems, it is essential to check that the two internal supplies are not overloaded. This check is especially important where analogue, counter and motion control modules are used, as these may consume a lot of power.

Atmospheric conditions	
Ambient temperature	Mounting on vertical surface with vertically aligned connection terminals: 0...+55 °C In all other mounting positions, a reduced temperature range of 0...+40 °C applies
Storage temperature	-25...+85 °C
Relative humidity	30...95% without condensation

Vibration resistance	
Vibration	according to EN/IEC61131-2: 5... 13.2 Hz constant amplitude 1.42 mm 13.2... 150 Hz, constant acceleration (simple gravitational acceleration)

Electrical safety	
Protection type	IP 20 according to EN60529
Air/leakage paths	according to EN61131-2 and EN50178: between circuits and bodies and between electrically isolated circuits: surge category II, fouling level 2
Test voltage	350 V / 50Hz AC for nominal unit voltage 24 VDC

Electromagnetic compatibility	
Electrostatic discharge	according to EN61000-4-2: 8 kV: air discharge 8 kV: contact discharge
Electromagnetic fields	according to EN61000-4-3: field intensity 10 V/m, 80... 1000 MHz
Bursts	according to EN61000-4-4: 4 kV on DC supply lines, 1/2 kV on I/O signal lines, 1 kV on interface lines
Noise emission PCD1, PCD2.M110/M120/M170	according to EN50081-1: Class B (residential areas)

Noise emission PCD2.M150/M480	according to EN50081-2: Class A (for industrial areas) Guidance on the correct use of these controls in residential areas can be found at <a href="http://www.sbc-support.com">www.sbc-support.com</a> (additional measures).
Noise immunity PCD1/ PCD2	according to EN50082-2

<b>Mechanism and mounting</b>	
Housing material	Base: Cover: Fibre optics: PC, crystal-clear
Mounting rail	Double top-hat rail as per EN50022-35 (2 x 35 mm)

3

<b>Connections</b>	
Screw terminals	Unless specified otherwise: for wires of 1.5 mm <sup>2</sup> (AWG 16) or 2 x 0.5 mm <sup>2</sup> (2 x AWG 20)
Plug-in screw terminals	The terminal block may only be plugged onto 20 times. It must then be replaced, to guarantee a reliable contact

<b>Standards / approvals</b>	
EN/IEC	EN/IEC61131-2 "Programmable controllers"
Shipbuilding	ABS, BV, DNV, GL, LRS, PRS. Please verify if your chosen product is mentioned in the list of corresponding Type-Approval-Company under <a href="http://www.sbc-support.com">www.sbc-support.com</a> .
cULus-listed	Please verify if your chosen product is listed in the corresponding Certificate under <a href="http://www.sbc-support.com">www.sbc-support.com</a> . The condition for cULus Compliance are mentioned on the sheet annexed to the product or can be required under <a href="http://www.sbc-support.com">www.sbc-support.com</a> .

### 3.3 System resources

#### 3.3.1 Program blocks

Type	Number	Addresses	Remarks
Cyclic organization blocks (COB)	16	0...15	Main program elements
Exception/system-dependent organization blocks (XOB)	32	0...31	called from the system
Program blocks (PB)	300	0...299	Sub-programs
Function blocks (FB)	1000	0...999	Sub-programs with parameters
Sequential blocks (SB)			for Grafctec programming of sequential processes
PCD1, PCD2.M110/M120/M150: total 2000 steps and transitions each	32	0...31	
PCD2.M170, PCD2.M480: total 6000 steps and transitions each (with PG5 ≥ 1.2 and firmware version ≥ 010)	96	0...95	

3

#### 3.3.2 Computation ranges for count types

Type		Remarks
Integers	– 2,147,483,648 to + 2,147,483,647	Format: decimal, binary, BCD or hexadecimal
Floating point numbers	– 9.22337 x 10 <sup>18</sup> to – 5.42101 x 10 <sup>-20</sup> + 9.22337 x 10 <sup>18</sup> to + 5.42101 x 10 <sup>-20</sup>	Instructions are provided to convert values held in SBC format (Motorola Fast Floating Point, FFP) to IEEE 754 format and vice versa.

### 3.3.3 Media

Type	Number	Addresses	Remarks
Flags (1 bit)	8192	F 0...8191	By default, flags are not volatile, but a volatile range can be configured, beginning with address 0
Register (32 bit) PCD1 PCD2.M110/120/M150/M170 PCD2.M480	4096 4096 16384	R 0...4095 R 0...4095 R 0...16383	For integer or floating point values
EEPROM register (32 bit) PCD1.M110/120/130 PCD1.M1x5 PCD2	5 50 50		Allow values to be stored that are retained even when the battery or the buffer capacitor are empty. SYSRD/SYSWR instructions can be used to read and write these values. The mechanism is intended for configuration data that does not change often; the number of write cycles is restricted.
Text/data blocks with/out extended user memory PCD1 PCD2.M110/M120/M150 PCD2.M170 PCD2.M480	4000/5000 4000/6000 8000 8191	X or DB 0...3999/4099 0...3999/5999 0...7999 0...8190	The texts 0..3999 are always written to the same memory area as the user program. Where the user memory has been extended, the base memory can be configured to hold RAM texts and DBs. The texts and DBs held in this way have addresses $\geq 4000$
Timers/counters (31 bit)	1600 <sup>1)</sup>	T/C 0...1599	The breakdown of timers and counters is configurable. Timers are periodically decremented by the operating system; the basic time unit can be set between 10 ms and 10 s
Constants with media code K	any number		Values 0..16383; may be used in instructions instead of registers
Constants with no media code	any number		Values - 2,147,483,648 to +2,147,483,647. Can only be loaded into a register with an LD command, and cannot be used in instructions instead of registers
Semaphores	100	0...99	Not relevant to PCD1/PCD2; used for locking resource accesses in multi-CPU systems like the PCD6

1) The number of timers configured should be only as many as required, to prevent unnecessary CPU loading

**3.3.4 Program structure for the Saia PCD® Classic family**

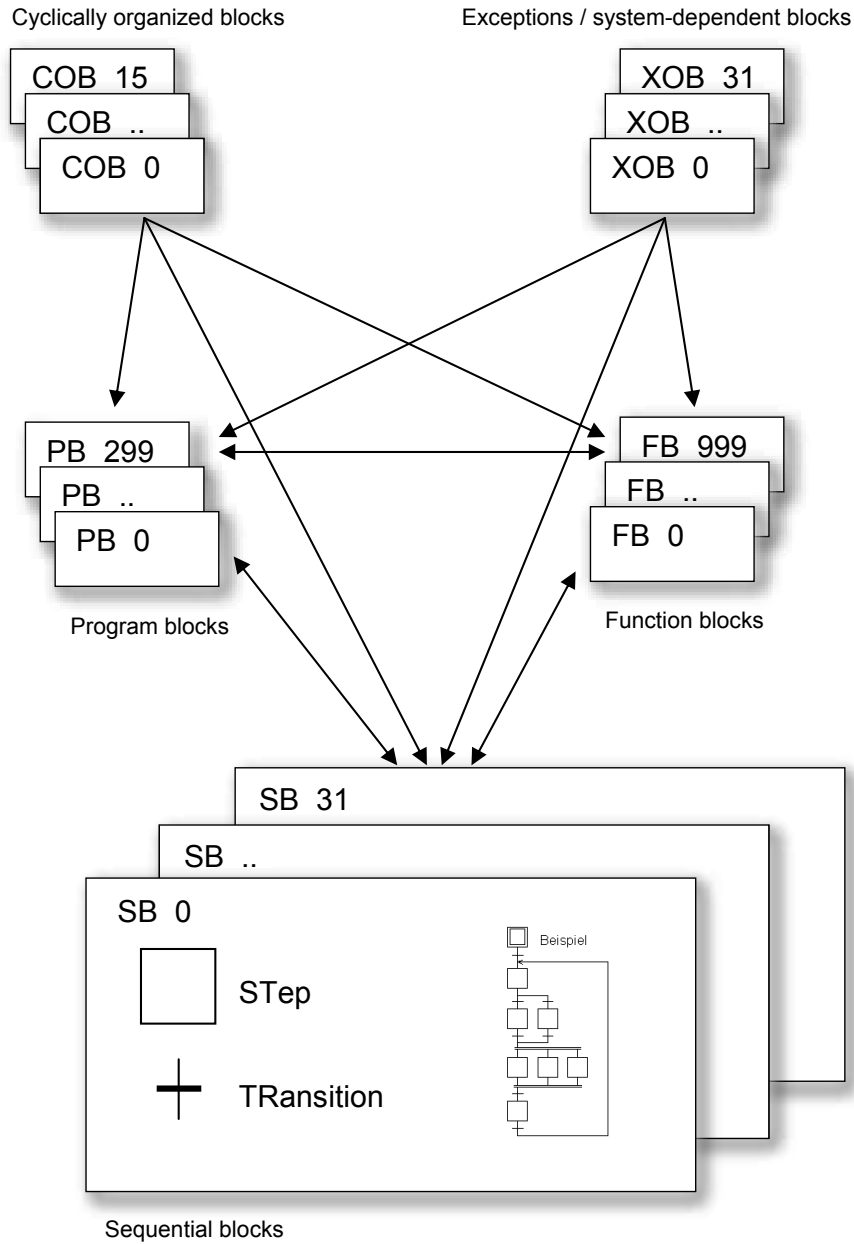

More information on this subject can be found in TIs 26/362 (PG5) and 26/354 (Operating system)

**3.4 CPU overview**

**3.4.1 PCD1.M1xx**

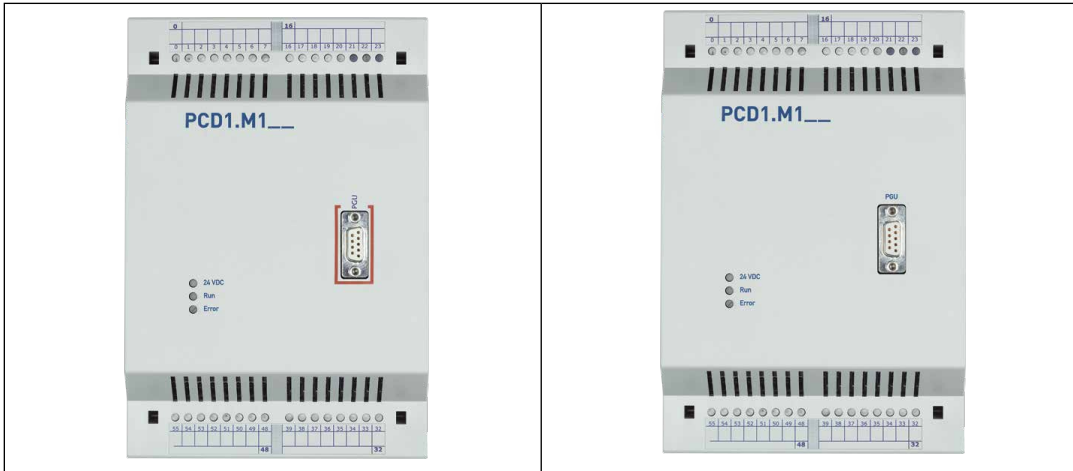

3

Differentiation of base units (general)	PCD1.M110	PCD1.M120	PCD1.M130	PCD1.M125	PCD1.M135
Number of inputs/outputs or I/O module sockets	64 <sup>1)</sup> 4				
I/O modules	all PCD2 I/O modules except PCD2.Gxxx				
Processor	68340 @ 16 MHz				
Processing time					
Bit instruction	z.B.	ANH	F 0	5 µs <sup>2)</sup>	
Word instruction	z.B.	ADD	R 0 R 1 R 2	20 µs <sup>2)</sup>	
Firmware	1 PROM in socket; from first half of 2004 soldered PROMs			soldered Flash Memory modules <sup>7)</sup>	
Minimum PG5 version	1.0, for TCP/IP 1.1			1.3.120	1.3.120
User memory					
RAM basic set up	17 Kbytes <sup>3)</sup>			128 KByte	
Expansion with RAM, EPROM or Flash EPROM	up to 128 Kbytes added up to 128 Kbytes added up to 112 Kbytes added			128 ... 512 KBytes 128 KBytes 112 ... 448 KBytes	
Clock (RTC)	no <sup>4)</sup>	yes, deviation < 30 ppm (80 secs/month)			
Data protection	30 days with Super Cap	7 days with Super Cap	1-3 years <sup>5)</sup> with CR2032 lithium battery	7 days with Super Cap	1-3 years <sup>5)</sup> with CR2032 lithium battery
Interrupt inputs	no	2			
Maximum input frequency	-	1 kHz <sup>6)</sup>			

1) Using digital I/O modules PCD2.E16x or A46x with 16 I/Os each  
 2) Typical values; the processing time is dependent on the load on the communication ports  
 3) When extended memory is used, 13 Kbytes of the base memory can be used to store RAM texts and DBs (text/DB addresses ≥ 4000)  
 4) When the HeaVAC library is used: The absence of the clock is reported as an error when processing the HeaVAC initialization block, and the clock timers cannot be used  
 5) The period given is a buffer time; it is dependent on the ambient temperature (a higher temperature means a shorter buffer time)  
 6) The 1 kHz applies with a pulse/pause ratio of 1:1 and refers to the total frequencies of the two inputs  
 7) Updates of the firmware via PGU possible

Differentiation of base units (ports)	PCD1.M110	PCD1.M120	PCD1.M130	PCD1.M125	PCD1.M135
Programming interface	PGU port D-Sub socket, 9-pole <sup>1)</sup> (for PCD8.K111 programming cable)				
Serial data port Socket A	1 RS-422, RS-485, built-in	1 RS-232, RS-422/485, MP bus or TTY current loop 20mA, plug-in (PCD7.F1xx modules)			
Field bus connections	SBC S-Bus				
	-	Ethernet-TCP/IP (Ether-S-Bus) <sup>2)</sup>	-	Ethernet-TCP/IP (Ether-S-Bus) <sup>2)</sup>	
	-	Profibus DP LonWorks <sup>®</sup> yes <sup>3)</sup>			
Socket B for network and/or data port, LED display, small terminal	for PCD7.D162 terminal kit only <sup>3)</sup>				

- 1) Can also be used as a serial data port, e.g. to connect a terminal; but this hampers troubleshooting with the debugger
- 2) Ethernet TCP/IP available as a configured system: PCD1.M130F655/PCD1.M135F655. If installed later, the cover must be replaced (item-no. 4 104 7409 0)
- 3) We recommend ordering the PCD2.D16x terminal kit mounted on the controller. If installed later, the cover must be replaced (item-no. 4 104 7338 0)

**3.4.2 Block diagram : PCD1.M1xx**

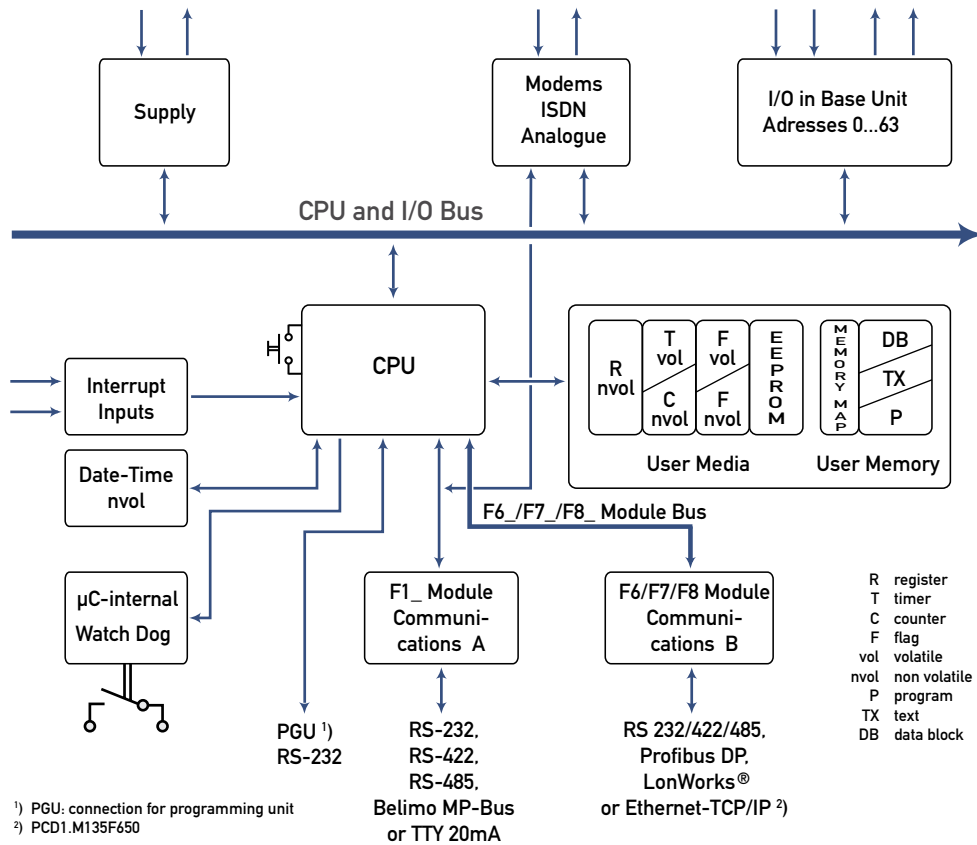



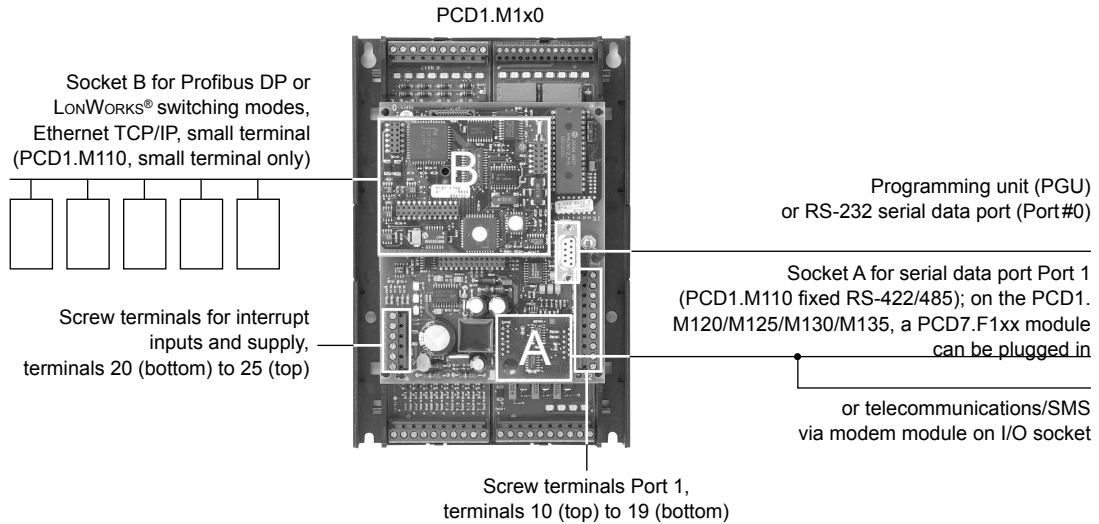

Removing the cover exposes components that are sensitive to electrostatic discharges.

**Recommendations:** Immediately before touching the electronic circuits, briefly touch the metal housing of the PGU connection. It is safer to use an anti-static wrist band, connected to the Minus of the system.



I/O modules and I/O terminal blocks may only be plugged in and removed when the Saia PCD® and the external +24 V are disconnected from the power supply.



Removing the cover exposes components that are sensitive to electrostatic discharges.

### 3.4.3 Hardware and firmware versions for the PCD1

The firmware versions for the PCD1.M1xx are generally upwardly compatible in terms of hardware, so old CPUs can be fitted with new firmware, in order to take advantage of new functions. This feature is highly valued, and we will try to retain it for as long as possible; however, we cannot guarantee this.

At this point, the following known restrictions apply:

- The use of intelligent communication modules such as Profibus DP, LON and Ethernet requires the minimum hardware and firmware versions. Please refer to the manuals for the relevant communication modules

### 3.4.4 Firmware Upgrade for the PCD1.M110, PCD1.M120 and PCD1.M130

The firmware for the PCD1.M1x0 is stored in a PROM. These chips can only be programmed once. With blank chips (item-no. 4 502 7178 0) and an EPROM burner with adapter for PLCC44 chips (e.g. Galep-4 with adapter 210841), new firmware chips can be burnt at any time. The file with the latest firmware version can be downloaded from [www.sbc-support.com](http://www.sbc-support.com).

At this point, the following known restrictions apply:

- In the course of 2004, soldered firmware chips were adopted; for a firmware update, these controls have to be returned to the factory

### 3.4.5 Firmware Upgrade for the PCD1.M125 and PCD1.M135

The Firmware is stored in a Flash EPROM, soldered to the motherboard. A firmware update can be applied by downloading a new version with the PG5. The procedure is as follows:

- Go to [www.sbc-support.com](http://www.sbc-support.com) and download the latest firmware version.
- Establish a connection between PG5 and the CPU, as for a download of an application (depending on the facilities available, serially via PGU cable, modem<sup>1)</sup>, USB, Ethernet).
- Open the Online Configurator and go offline.
- From the Tools menu, select "Download Firmware", then use the Browse function to select a path to the file for the new firmware version. Ensure that only one file is selected for downloading.
- Start the download.
- After the download, the power supply to the Saia PCD<sup>®</sup> must not be interrupted for 3 minutes (CPLD programming sequence). Otherwise, the CPU may be blocked in such a way that it needs to be returned to the factory.

1) A modem connection is not always reliable. A modem may become blocked in such a way that remote access is no longer possible. In such cases, an on-site visit will be necessary. Other connection options are preferable.

3.4.6 PCD2.M1x0/M480 Hardware and Firmware

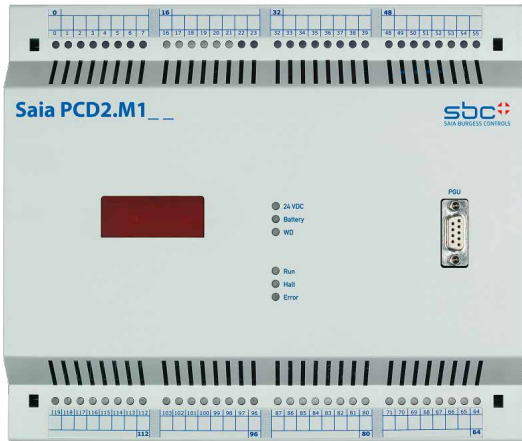

PCD2.M1x0

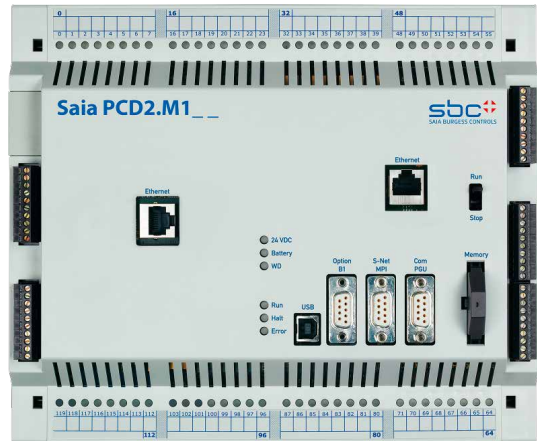

PCD2.M480

3

Differentiation of PCD2 base units (general, part 1)	M110	M120	M150	M170	M480
I/O bus connection for expansion units	No	Yes			
Number of inputs/outputs or I/O module sockets:					
When PCD2 components used exclusively	128 <sup>1)</sup> 8	255 <sup>1)2)</sup> 16			
When expanded with PCD3 components	-	255 <sup>2)</sup> 16	510 <sup>2)</sup> 32	1023 <sup>2)</sup> 64	
When expanded with PCD4 components	-	255 <sup>1)2)3)</sup> 16			
Processor (Motorola)	68340 16 MHz		68340 25 MHz		CF 5407 162 MHz
Processing time					
Bit instr, e.g. ANH F 0	3.8 µs <sup>4)</sup>		1.8 µs <sup>4)</sup>		0.12 µs <sup>4)</sup>
Word instr, e.g. ADD R 0	20 µs <sup>4)</sup>		10 µs <sup>4)</sup>		0.4 µs <sup>4)</sup>
Firmware, firmware update	2 EPROMs on DIL socket, plug-in		*	Firmware memory soldered on, download from PG5 environment	
Minimum PG5 version	1.0.xxx	1.0.xxx	1.0.xxx	1.1.xxx	1.2.xxx

- 1) Using digital I/O modules PCD2.E16x or A46x with 16 I/Os each
- 2) On all PCD2s, address 255 is reserved for the watchdog; on the M170, address 511 is also reserved for this purpose. The I/Os reserved for the watchdog cannot be used by the user, and no analogue or H modules may be attached to sockets with base address 240 (and on the M170, 496 also)
- 3) Not all PCD4 I/O modules are suitable for use with PCD2 CPUs; please refer to the section on "Expansion with PCD4 components"
- 4) Typical values; the processing time is dependent on the load on the communication ports

*	Firmware Update for PCD2.M150
FW < V0D0	2 Flash EPROM on DIL socket, plug-in
FW ≥ V0D0	soldered Flash Memory modules (Updates of the firmware via PGU possible)

Differentiation of PCD2 base units (general, part 2)	M110	M120	M150	M170	M480
User memory RAM basic set up  Expansion with RAM, EPROM or Flash EPROM	Hardware version >= J: 128 Kbytes <sup>1)</sup> up to 512 Kbytes added Hardware version H: 32 Kbytes <sup>1)</sup> up to 512 Kbytes added Hardware version < H: 32 Kbytes <sup>1)</sup> up to 128 Kbytes added		128 Kbytes <sup>1)</sup> up to 512 Kbytes added	1 MByte RAM	
PCD7.R400 flash card as plug-in (backup of user program)	no			yes	
Clock (RTC)	yes, deviation < 15 ppm (40 secs/month)				
Data protection	CR 2032 lithium battery 1-3 years <sup>2)</sup>				
Number of interrupt inputs	no	2	2	2	4
Maximum input frequency	-	1 kHz <sup>3)</sup>	1 kHz <sup>3)</sup>	1 kHz <sup>3)</sup>	1 kHz <sup>4)</sup>

1) When extended memory is used, a large part of the base memory can be used to store RAM texts and DBs (text/DB addresses ≥ 4000)

2) The period given is a buffer time; it is dependent on the ambient temperature (a higher temperature means a shorter buffer time)

3) The 1 kHz applies with a pulse/pause ratio of 1:1 and refers to the total frequencies of the two inputs

4) The 1 kHz applies with a pulse/pause ratio of 1:1

Differentiation of PCD2 base units (ports)	M110	M120	M150	M170	M480
Programming interface	PGU port D-Sub socket, 9-pole <sup>1)</sup> (for PCD8.K111 programming cable) PCD2.M480, also USB port <sup>2)</sup>				
Serial data port Socket A	1 x RS-232, RS-422/485 or TTY loop circuit 20mA, plug-in (PCD7.F1xx modules)				
Port#0 (PGU) also available as RS-485 interface (either RS-232 or RS-485)		✓			✗
Additional serial data port RS-485 (Port 6, up to 115 kbps)		✗			✓
Profi-S-Net interface (up to 1.5 Mbps)		✗			✓
Field bus connections:					
Serial-S-Bus (SBC S-Bus)	✓				
Ether-S-Bus (Ethernet-TCP/IP)	✗		✓ <sup>3)</sup>		✓
Profi-S-Bus	✗				✓
Profibus FMS	✗		✓		✗ <sup>4)</sup>
Profibus DP Master	✗	✓			
Profibus DP Slave	✗		✓		(✓) <sup>4)</sup>
LONWORKS®	✗		✓		✗ <sup>4)</sup>
Socket for network and/or data port, LED display, small terminal	(1 × B) <sup>5)6)</sup>	1 × B <sup>6)</sup>	1 × B <sup>6)</sup>	B1 and B2 <sup>6)7)8)</sup>	

- 1) Can also be used as a serial data port, e.g. to connect a terminal; but this hampers commissioning and troubleshooting with the debugger
- 2) The USB port is type "USB 1.1 Slave Device 12 Mbps" and can only be used for programming and as an S-Bus Slave, together with certain software products (Webconnect, ViSi-PLUS with S-Driver)
- 3) Ethernet TCP/IP available as a configured system on the PCD2.M150: PCD2.M150F655. If installed later, the cover must be replaced (item-no. 4 104 7410 0)
- 4) Implementation of LONWORKS and Profibus FMS is technically feasible, but not planned. Profibus DP Slave with Profi S-Net port up to 1.5 Mbps; a 12 Mbps solution with PCD7.F770 is not feasible
- 5) On the PCD2.M110, Socket B can only be used to attach the PCD7.D16x terminal kit and the PCD2.F510 LED display
- 6) We recommend ordering the PCD7.D16x terminal kit mounted on the control. If installed later, the red viewing window must be removed, and four holes drilled for the terminal fixing screws (guide holes are provided on the inside of the cover)
- 7) Not all communication modules can be mounted on both sockets; please refer to the section on "Communication"
- 8) The PCD2.F510 and PCD2.F530 LED displays cannot be used with the PCD2.M170 and PCD2.M480

3.4.7 Block diagram : PCD2.Mxx0

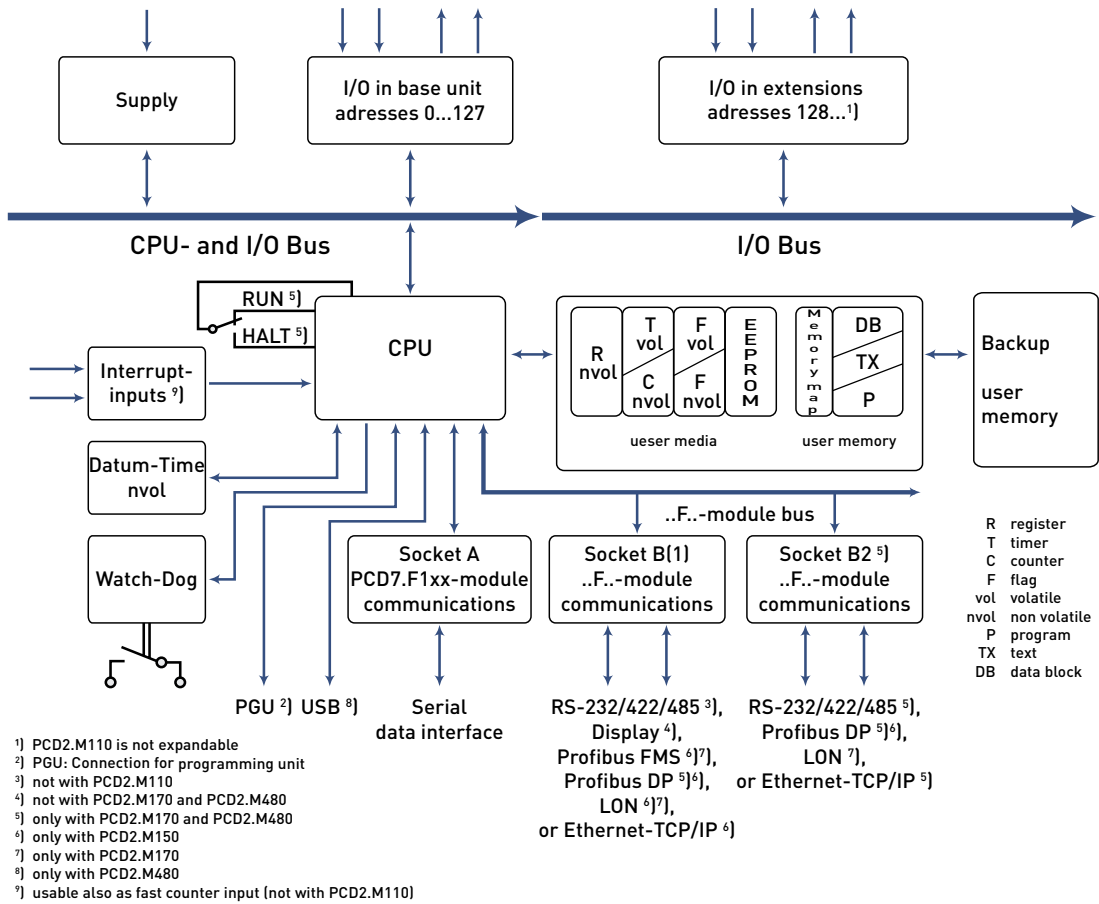

Socket B for Profibus DP/FMS or LonWorks® switching mode, for serial data ports, 6-digit display, small terminal

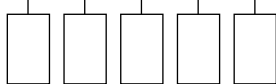

Screw terminals for supply, watch-dog and Port#0 as RS-485

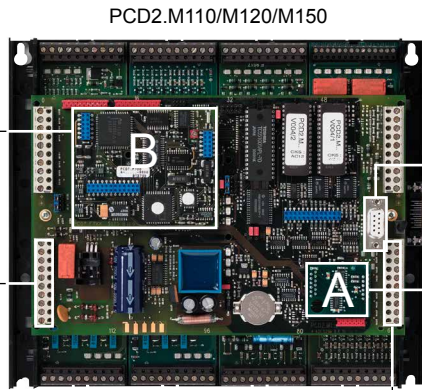

Programming unit (PGU) or RS-232 serial data port (Port#0)

Socket A for serial data port Port 1

or telecommunications/SMS via modem module on I/O socket

Screw terminals Port 1

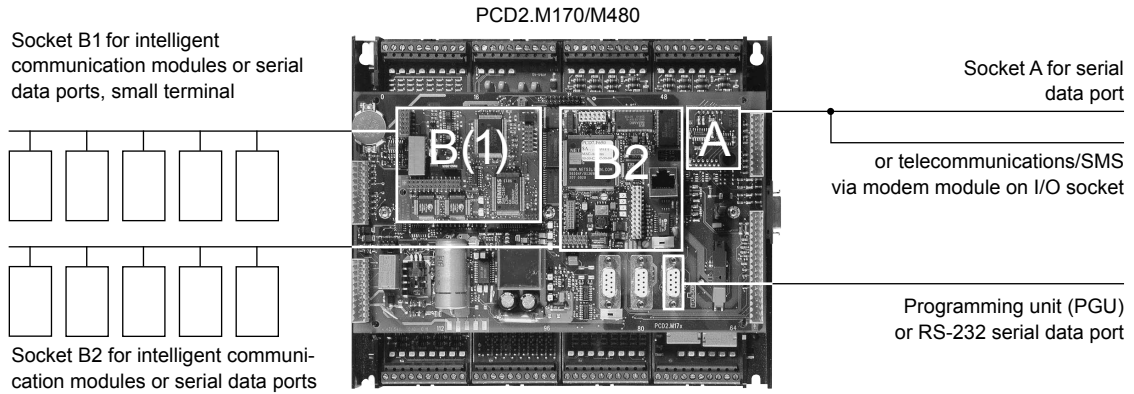

3



Removing the cover exposes components that are sensitive to electrostatic discharges.

**Recommendations:** Immediately before touching the electronic circuits, briefly touch the metal housing of the PGU connection. It is safer to use an anti-static wrist band, connected to the Minus of the system.



I/O modules and I/O terminal blocks may only be plugged in and removed when the Saia PCD® and the external +24 V are disconnected from the power supply.



Removing the cover exposes components that are sensitive to electrostatic discharges.

### 3.4.8 Hardware and firmware versions for the PCD2.M110/M120

The firmware versions for the PCD2.M110/M120 are generally upwardly compatible in terms of hardware, so old CPUs can be fitted with new firmware, in order to take advantage of new functions. This feature is highly valued, and we will try to retain it for as long as possible; however, we cannot guarantee this.

At this point, the following known restrictions apply:

- Hardware version D1 from July/August 1995 only works with firmware version \$34; a firmware update is not possible with these controllers
- The use of intelligent communication modules such as Profibus DP, LON and Ethernet requires the minimum hardware and firmware versions. Please refer to the manuals for the communication modules

**Hardware version H** introduced significant changes:

- Hardware clock on the base circuit board (previously on the PCD2.Fxx0 communication modules)
- CR2032 lithium buffer battery (older hardware versions can be easily recognized by the two round LR03 batteries)
- Internal 5 V supply now rated up to 1.6 A (previously 1.1 A)
- Option to extend memory with 4 MBit chips (giving 512 Kbytes)

From **hardware version J**, the default set up of the base memory is 128 Kbytes (previously 32 Kbytes).

The firmware for the PCD2.M110/M120 is stored in two EPROMs. **With an EPROM burner (e.g. Galep-4), new firmware chips can be burned at any time.** The file with the latest firmware version can be downloaded from [www.sbc-support.com](http://www.sbc-support.com). Blank firmware chips can be obtained under item-no. 4 502 7126 0 (two chips per CPU need to be ordered).

### 3.4.9 Hardware and firmware versions for the PCD2.M150, FW < V0D0 (until early 2007)

The firmware versions for the PCD2.M150 are generally upwardly compatible in terms of hardware, so old CPUs can be fitted with new firmware, in order to take advantage of new functions. This feature is highly valued, and we will try to retain it for as long as possible; however, we cannot guarantee this.

The firmware for the PCD2.M150 is stored in two Flash EPROMs. **With an EPROM burner (e.g. Galep-4), new firmware chips can be burned at any time;** updating via download, as with the M170/M480 is not possible. The file with the latest firmware version can be downloaded from [www.sbc-support.com](http://www.sbc-support.com). Blank firmware chips can be obtained under item-no. 4 502 7341 0 (two chips per CPU need to be ordered).



### 3.4.10 Hardware and firmware versions for the PCD2.M150, FW ≥ V0D0 (since early 2007)

The Firmware is stored in a Flash EPROM, soldered to the motherboard. A firmware update can be applied by downloading a new version with the PG5. The procedure is as follows:

- Go to [www.sbc-support.com](http://www.sbc-support.com) and download the latest firmware version.
- Establish a connection between PG5 and the CPU, as for a download of an application (depending on the facilities available, serially via PGU cable, modem<sup>1)</sup>, USB, Ethernet).
- Open the Online Configurator and go offline.
- From the Tools menu, select “Download Firmware”, then use the Browse function to select a path to the file for the new firmware version. Ensure that only one file is selected for downloading.
- Start the download.
- After the download, the power supply to the Saia PCD® must not be interrupted for 3 minutes (CPLD programming sequence). Otherwise, the CPU may be blocked in such a way that it needs to be returned to the factory.

1) A modem connection is not always reliable. A modem may become blocked in such a way that remote access is no longer possible. In such cases, an on-site visit will be necessary. Other connection options are preferable.

### 3.4.10 Hardware and firmware versions for the PCD2.M170/M480

The firmware versions for the PCD2.M170/M480 are generally upwardly compatible in terms of hardware, so old CPUs can be fitted with new firmware, in order to take advantage of new functions. This feature is highly valued, and we will try to retain it for as long as possible; however, we cannot guarantee this.

The firmware for the PCD2.M170/M480 is stored in a Flash EPROM, soldered to the motherboard. A firmware update can be applied by downloading a new version with the PG5. The procedure is as follows:

- Go to [www.sbc-support.com](http://www.sbc-support.com) and download the latest firmware version.
- Establish a connection between PG5 and the CPU, as for a download of an application (depending on the facilities available, serially via PGU cable, modem<sup>1)</sup>, USB, Ethernet).
- Open the Online Configurator and go offline.
- From the Tools menu, select “Download Firmware”, then use the Browse function to select a path to the file for the new firmware version. Ensure that only one file is selected for downloading.
- Start the download.
- After the download, the power supply to the Saia PCD® must not be interrupted for 3 minutes (CPLD programming sequence). Otherwise, the CPU may be blocked in such a way that it needs to be returned to the factory.

1) A modem connection is not always reliable. A modem may become blocked in such a way that remote access is no longer possible. In such cases, an on-site visit will be necessary. Other connection options are preferable.

### 3.5 Mounting

The PCD1 and PCD2 can be snapped onto two 35 mm top-hat rails according to DIN EN60715TH35 (formerly DIN EN50022). The PCD1/PCD2 can also be screwed to any other flat surface with 4 M4 screws; the grooves provided for this purpose can be accessed by lifting off the snap-on cover.

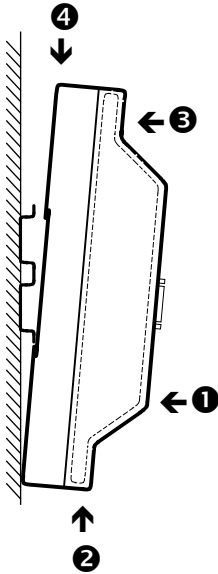

#### Mounting the PCD1/PCD2 on the top-hat rail

- ❶ Press bottom of housing onto the mounting surface
- ❷ Press upwards against the top-hat rail
- ❸ Press top of housing against the mounting surface and snap into place
- ❹ Push the housing down onto the top-hat rail to ensure that it is secure

#### Removal

To remove the housing, push upwards and pull out.

#### 3.5.1 Mounting position and ambient temperature

A vertical surface is normally used to mount the module holder; the I/O connections to the modules then also run vertically. In this mounting position, the ambient temperature may be from 0 °C to 55 °C. In all other positions, air convection works less well, and an ambient temperature of 40 °C should not be exceeded.

### 3.6 Expansion housings and bus cables

The PCD2.M120/M150/M170/M480 can be expanded with PCD2, PCD3 or PCD4 components, and additional module sockets are provided:

Type	M120/M150	M170	M480
Maximum number of inputs/outputs or I/O module sockets for the system:			
When PCD2 components used exclusively		255 <sup>1)2)</sup> 16	
When expanded with PCD3 components	255 <sup>1)2)</sup> 16	510 <sup>1)2)</sup> 32	1023 <sup>1)2)</sup> 64
When expanded with PCD4 components		255 <sup>2)3)</sup> 16	

1) Using digital I/O modules PCD2/3.E16x or A46x with 16 I/Os each

2) On all PCD2s, address 255 is reserved for the watchdog; on the M170, address 511 is also reserved for this purpose. The I/Os reserved for the watchdog cannot be used by the user, and no analogue or H modules may be attached to sockets with base address 240 (and on the M170, 496 also)

3) Not all PCD4 I/O modules are suitable for use with PCD2 CPUs; please refer to the section on [“Expansion with PCD4 components”](#)

### 3.6.1 Expansion with PCD2 components

The PCD2.C100 expansion housing provides space for 8 additional I/O modules. The dimensions of the housing match those of the PCD2.Mxx0 base unit.

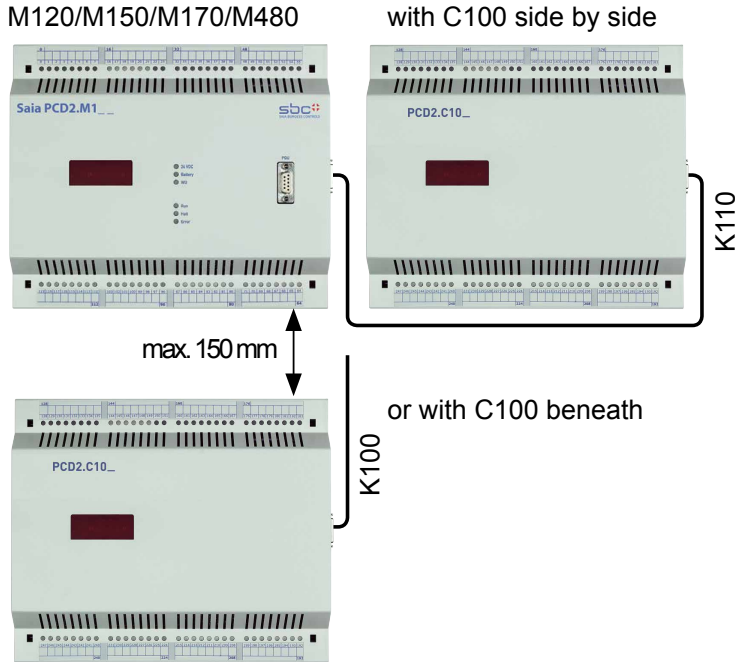

The PCD2.C150 expansion housing provides space for 4 additional I/O modules. The dimensions of the housing match those of the PCD2.Mxx0 base unit.

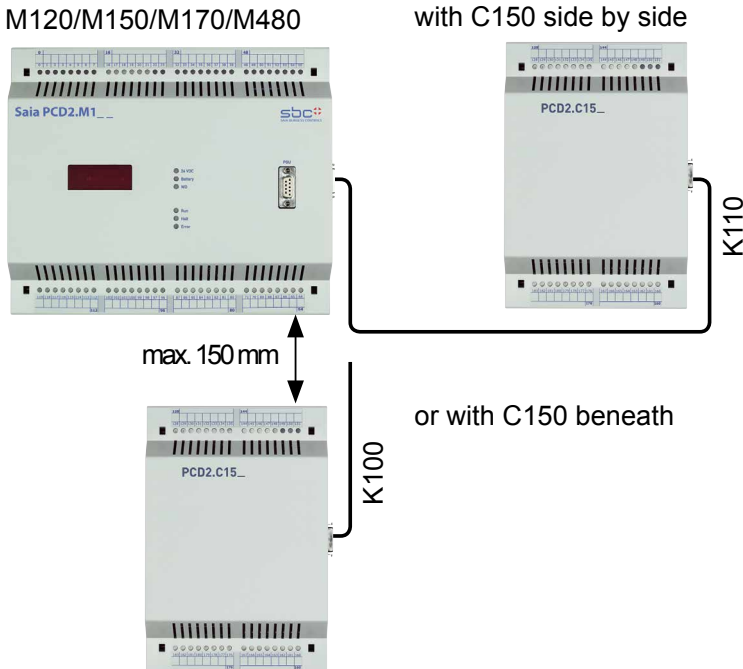

The connection to the base unit is via the 26-core extension cable

- PCD2.K100 for mounting beneath each other, or
- PCD2.K110 for mounting side-by-side
- PCD2.K120 for specific applications (length 2 m)

The PCD2.Mxx0 base units have 8 sockets for input/output modules. The sockets are numbered clockwise from the top left, from 0 to 7.

The controllers can also be expanded with PCD2.C150 (4-socket) and PCD2.C100 (8-socket) expansion housings to provide up to 15 sockets.

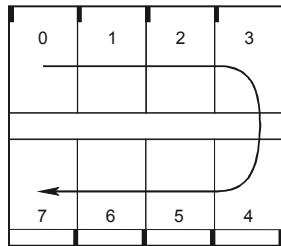

**Base unit PCD2.Mxx0**

Sockets numbered clockwise from 0 to 7.  
 All modules of types E, A, W and H can run in any socket.  
 The PCD2.T8xx modems cannot be used in all sockets; please refer to the manual [26/771](#) for these modules

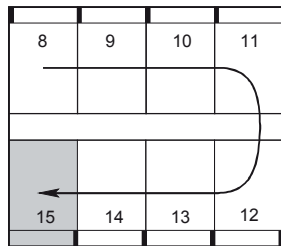

**PCD2.K100 or K110 bus extension cable**

**PCD2.C100 expansion housing**

Sockets numbered clockwise from 8 to 15.  
 Socket 15 (shaded) cannot be used for modules of types W or H.

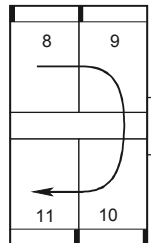

**PCD2.C150 expansion housing**

Sockets numbered clockwise from 8 to 11

**3.6.2 Expansion with PCD3 components**

For local expansion, the PCD3 LIO (Local I/O) modules can be used:

- PCD3.C200 4 plug-in I/O modules, integrated 24 VDC / 5 VDC supply for modules and signal refresh.
- PCD3.C100 4 plug-in I/O modules
- PCD3.C110 2 plug-in I/O modules

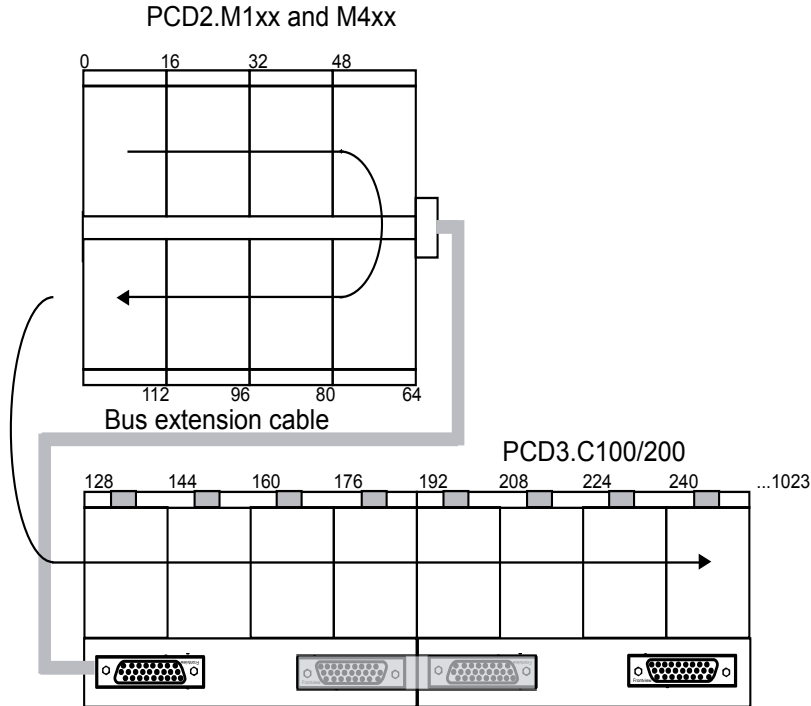

For decentralized expansion, the PCD3 RIO (Remote I/O) modules can be used:

- PCD3.T760 Integrated Profibus DP Slave / Profi S-Net Slave connection up to max. 1.5 MBit/s
- 4 plug-in I/O cassettes
- Integrated web server for diagnostics, support and comissioning (Connection to PC via optional PCD3.K225 connector cable)

The maximum number of I/Os is dependent on the controller being used:

Saia PCD® type	Maximum number PCD3 I/Os	Maximum number I/Os per system
PCD2.M120/150	127	255
PCD2.M170	382	510
PCD2.M480	897	1023
PCD3.RIO nodes	256 per node	Determined by the maximum size of the I/O process map for DP Master

When selecting I/O cassettes, ensure that the internal 5 V and +V supply is not overloaded.

Detailed information on planning combined PCD2/PCD3 systems can be found in the PCD3 manual [26/789](#).

**3.6.3 Expansion with PCD4 components**

Starting from a PCD2.M120/M150/M170/M480, the PCD4.C225 coupling bus module makes it possible to run the following I/O modules and manual control modules from the PCD4 series:

Digital input/output modules	Manual control modules
PCD4.E11x	PCD4.A810
PCD4.E60	PCD4.A820
PCD4.A200	
PCD4.A250	
PCD4.A350	
PCD4.A400	
PCD4.A410	
PCD4.B90x	



Any PCD4 I/O modules not listed are not supported.

As shown in the illustration below, the PCD4.C225 is connected to the PCD2 via a PCD2.K100/K110/K120 extension cable.

Using standard PCD4.C220 or PCD4.C260 bus modules, up to 6 additional module sockets can be attached to the right-hand side of the PCD4.C225 coupling bus module (making a total of 8 PCD4 sockets).

It is necessary to ensure that the internal 5 V and +V supply for the PCD2 is not overloaded. The power consumption for the PCD4 modules can be found in manual 26/734.

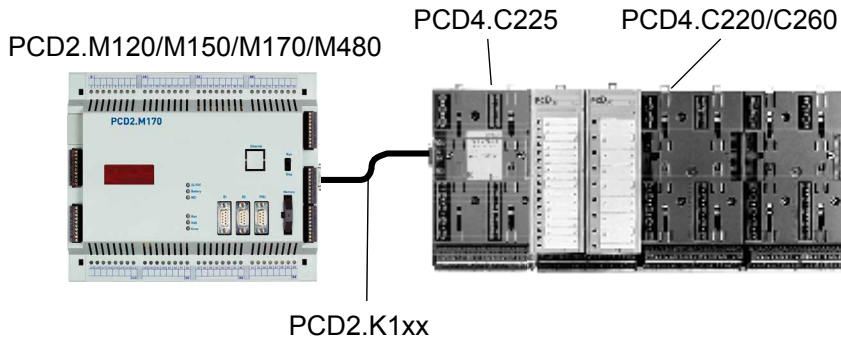

### 3.7 Installation and addressing of PCD2 I/O modules

#### 3.7.1 Insertion of I/O modules

The I/O module is inserted from the side, pushed towards the middle of the unit until it reaches the end stop, and snapped into the retaining catch.

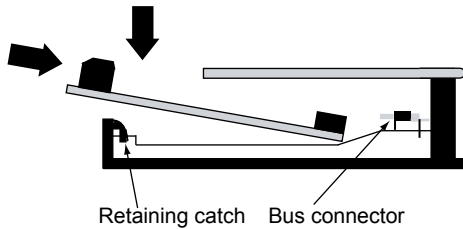

I/O modules and I/O terminal blocks may only be plugged in and removed when the Saia PCD® and the external +24 V are disconnected from the power supply.

#### 3.7.2 Address and terminal designation

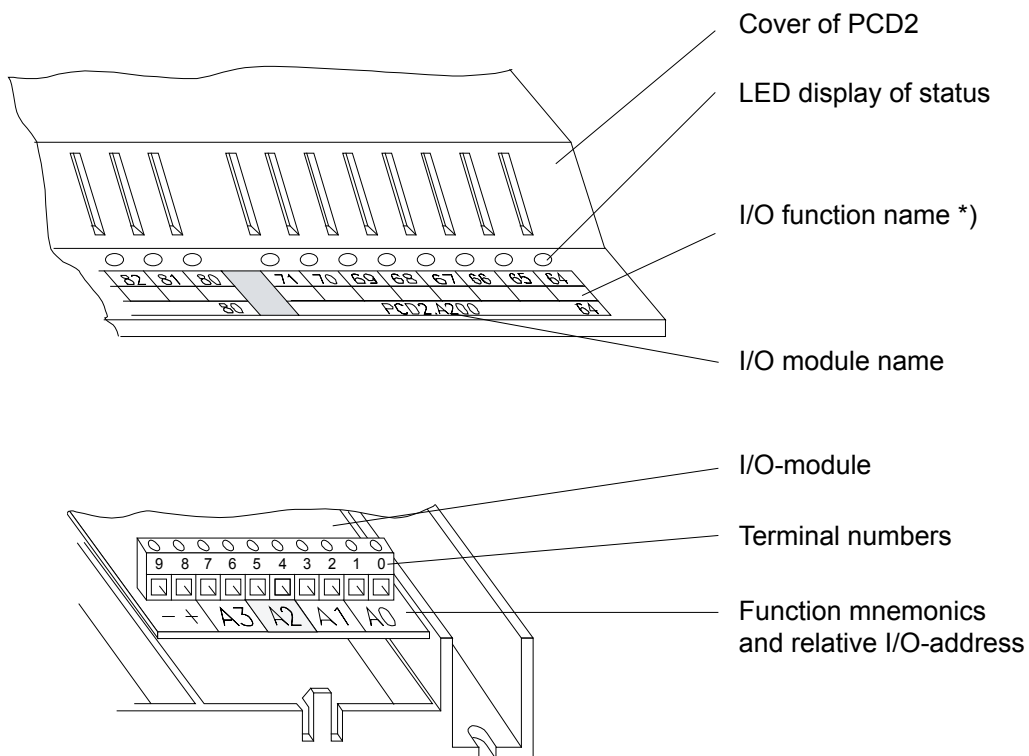

\*) All PCD1/PCD2 units are suitably labelled



Removing the cover gives access to terminals, but also exposes components that are sensitive to electrostatic discharges.



### 3.7.3 Cable layout

Wiring to the I/O modules can be laid in the cable channels on both sides.

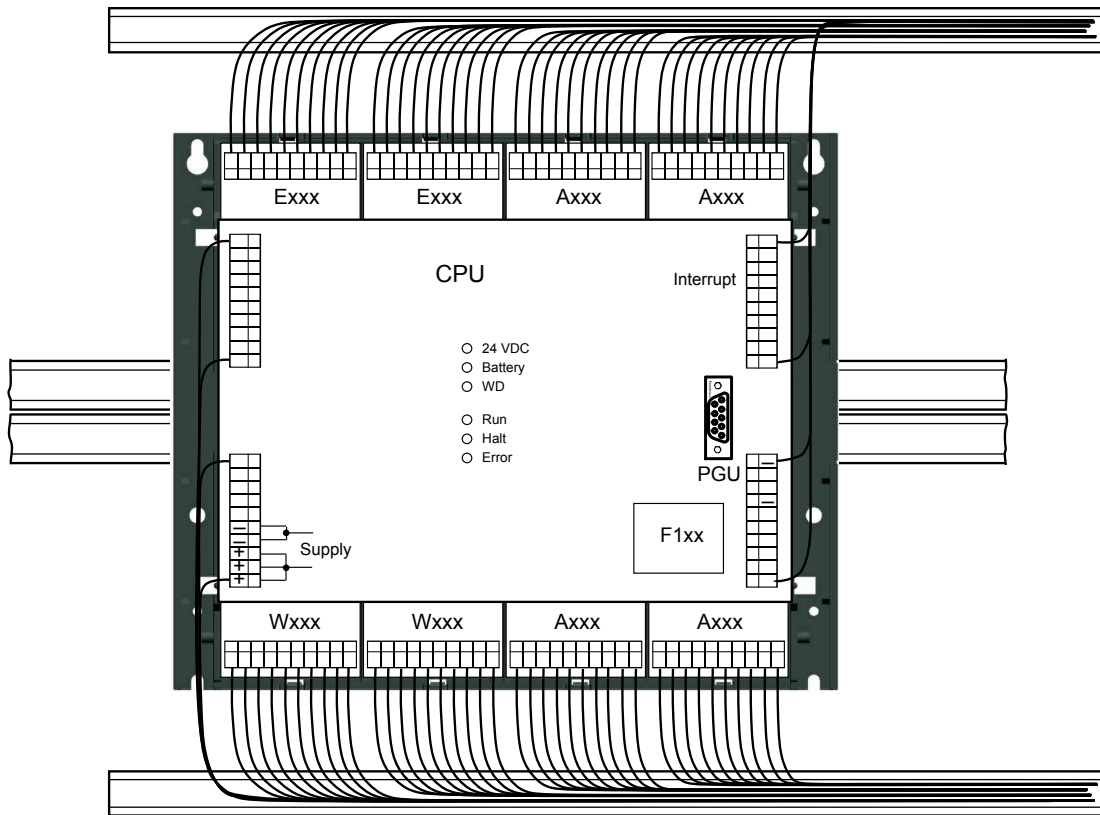

3

The cables to the terminals on the motherboard are run through the two side channels from the bottom or from the top.

On the PCD2.M170 and the PCD2.M480, the terminals on the motherboard are accessible without removing the cover.

Following these rules will ensure that the LEDs are visible and the bus connections remain accessible.

**3.8 Dimensions**

**PCD1.M1xx/PCD2.C150**

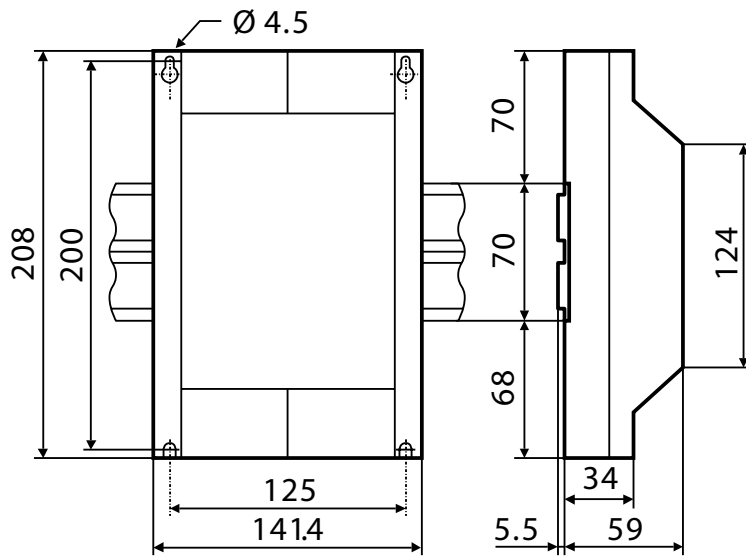

**PCD2.Mxx0/PCD2.C100**

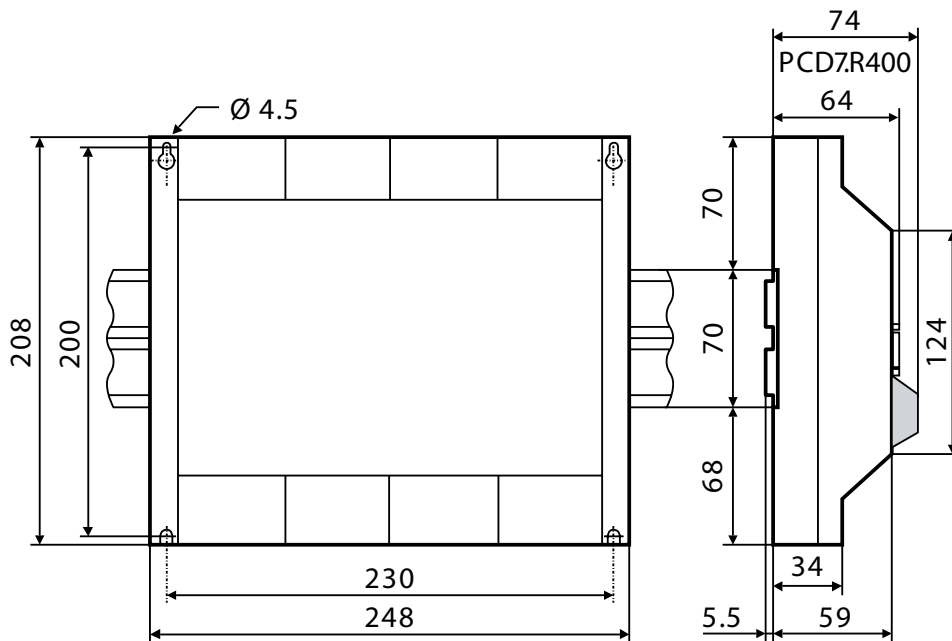

### 3.9 Power supply and connection plan

#### 3.9.1 External power supply

##### Simple, small installations

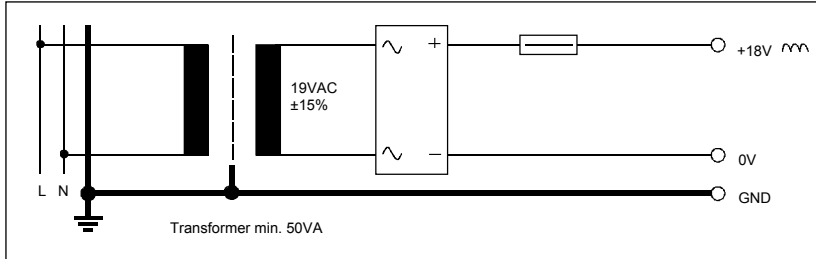

3

- Sensors: Electro-mechanical switches
- Actuators: Relays, lamps, small valves with < 0.5 A switching current



The transformer voltage of 19 VAC ±15% must be maintained. If not, the supply voltage at the input to the Saia PCD® may become too high and destroy it.



The PCD2. H1xx, H2xx, H3xx, PCD7.D1xx, D2xx and PCA2.D12/D14 modules must be connected to a smoothed 24 VDC supply

##### Small to medium installations

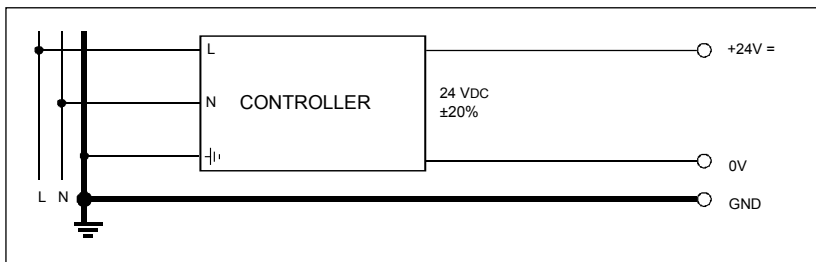

Controller: usual primary switched network component

- Sensors: Electro-mechanical and proximity switches, photoelectric barriers
- Actuators: Relays, lamps, displays, small valves with < 0.5 A switching current

**3.9.2 Earthing and connection plan**

**Ground wire plan with earthing bar**

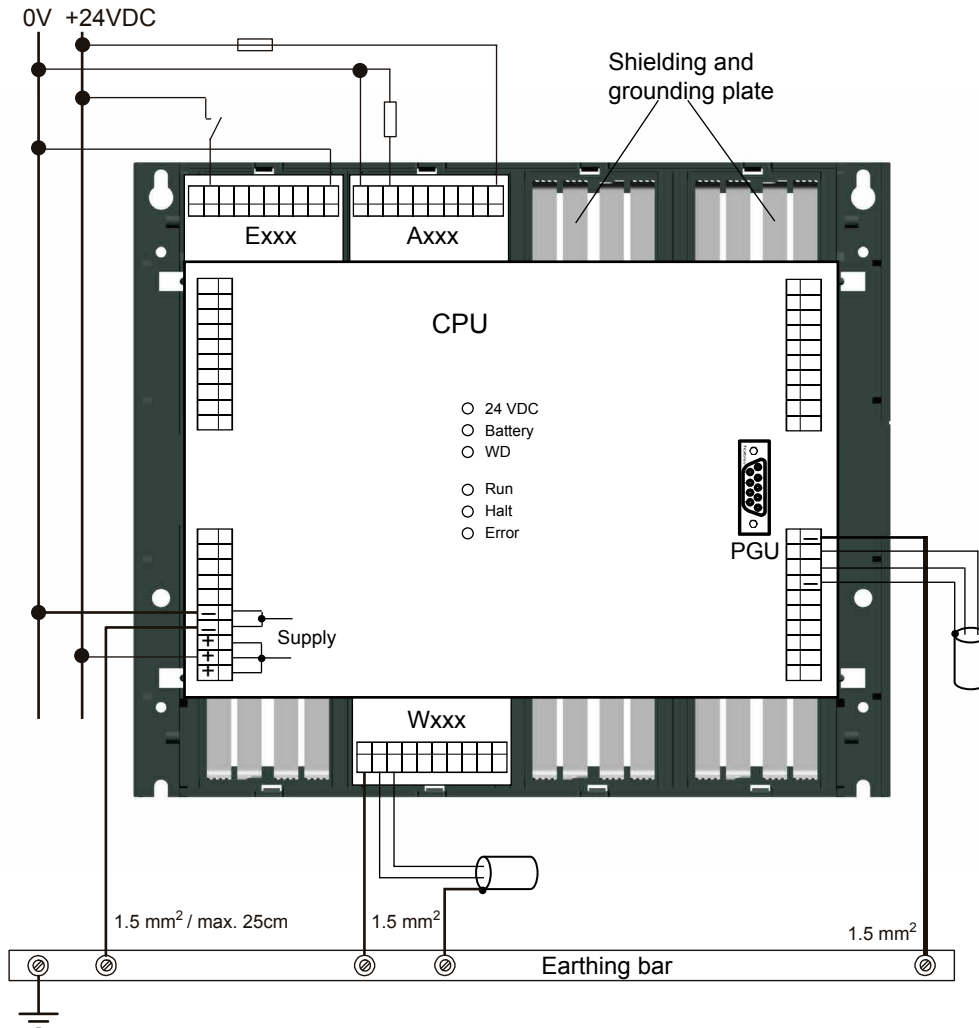

In the bottom part of the PCD1/PCD2 housing there is a shielding and earthing plate. This constitutes the common, large-area ground for all I/O modules and for the external power supply.

When a module is plugged in at the I/O level, the blades on this plate ensure a reliable multi-point contact to the relevant module.

The zero-potential (Minus pole) of the 24 V supply is connected to the Minus terminal of the PCD1/PCD2 supply. This should be connected to the earthing bar with the shortest possible wire (< 25 cm) of 1.5 mm<sup>2</sup>. The same applies to the Minus connection to the F1xx or the interrupt terminal.

Any shielding of analogue signals or communication cables should also be brought to the same earth potential, either via a Minus terminal or via the earthing bar.

All Minus connections are linked internally. For problem-free operation, these connections should be reinforced externally with short wires of 1.5 mm<sup>2</sup>.

**Star-shaped ground wire plan (alternative to earthing bar)**

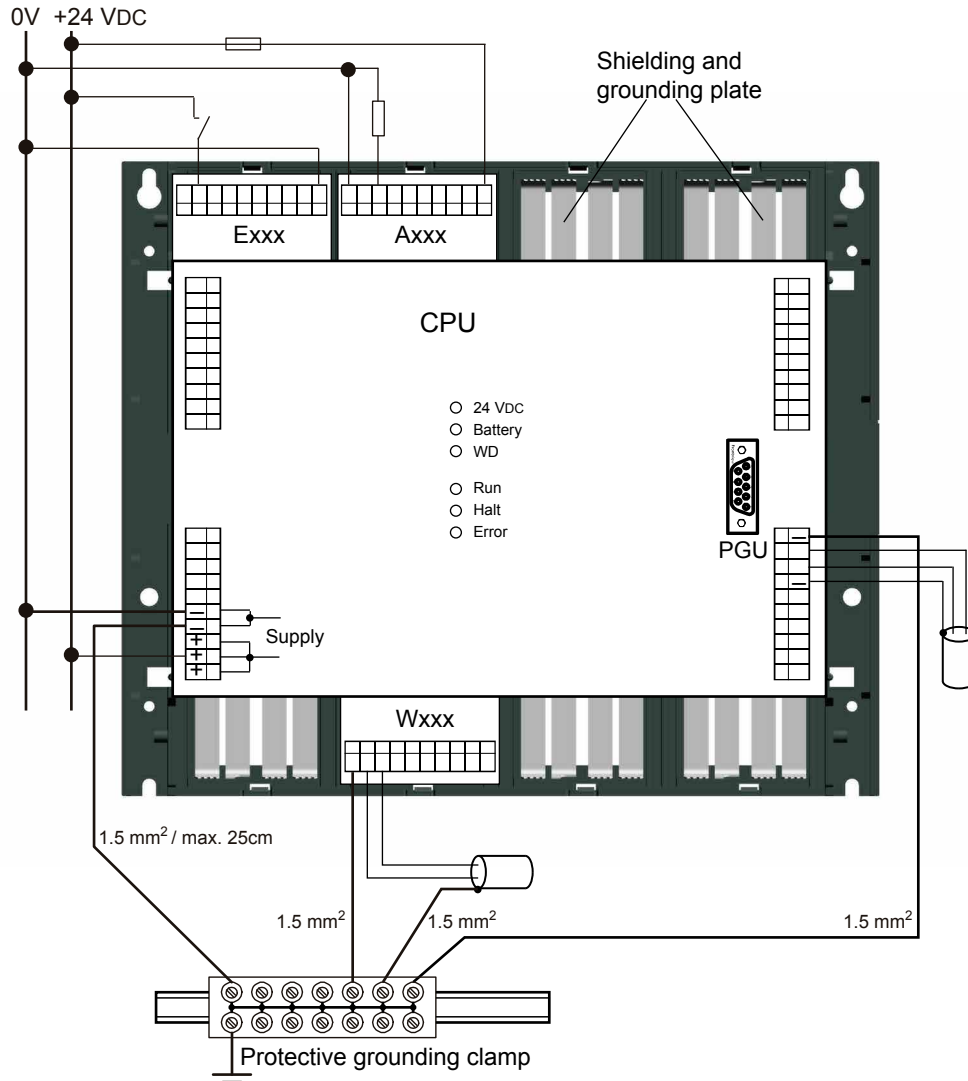

3

The star-shaped ground wire plan should only be used where there is no earthing bar.

**Examples of ground wire terminals for 35 mm mounting rails<sup>1)</sup>**

Manufacturer	Connection type	Type	End plate	End bracket/ end clamp
Weidmüller	Screw connection	WPE4 101 010 0000		
Weidmüller	Screwless spring clip	ZPE4 163 208 0000	ZAP/TB4 163 209 0000	ZEW 954 000 0000
Wago	Screwless cage clamp	default: 281-107	grey: 281-301 orange: 281-302	6 mm: 249-117 10 mm: 249-116
Wieland	Screw connection	WKI4SL/35	AP2.5-4 grey	9708/2 S 35
Wieland	Spring clip	WKI4SL/35	APF2.5-4 GN	WEF 1/35

1) DIN EN 60715 TH35

### 3.9.3 Internal power supply

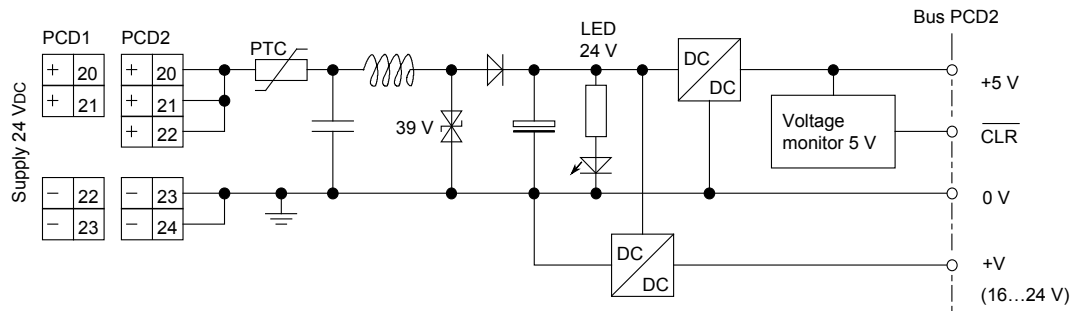

3

### 3.9.4 Capacity of internal power supply

Starting from the base units, the following currents are available for the plug-in modules:

#### +5 V:

PCD1:	:	750 mA
PCD2.M110/M120	:	1600 mA (before hardware version H: 1100 mA)
PCD2.M150/M170	:	1600 mA
PCD2.M480	:	2000 mA

#### +V (16...24 V)

PCD1:	:	100 mA
PCD2:	:	200 mA



### 3.11 PCD2.M1x0/M480 operating states

The CPU can assume the following operating states: START, RUN, CONDITIONAL RUN, STOP, HALT and RESET

The display uses 3 LEDs:    RUN                                LED yellow  
     HALT                                LED red  
     ERROR                                LED yellow

3

	START	RUN	COND. RUN	STOP	HALT	RESET
RUN	●/○	●	●/○	○	○	●
HALT	●/○	○	○	○	●	●
ERROR	●/○	1)	1)	1)	1)	●

- <sup>1)</sup> An ERROR may be signalled by the LED in operating states RUN, CONDITIONAL RUN, STOP or HALT. In the event of an error, the LED only lights up if there is no XOB 13 programmed to deal with this error.
- LED on
  - /○ LED flashing
  - LED off

- START                    Self-diagnosis for approx. 1s after switching on or after a Restart
- RUN                    Normal processing of the user program after START. Where a programming device is connected via a PCD8.K11x in PGU mode (e.g. PG5 in PGU mode), the CPU automatically goes into the STOP state and not the RUN state; this is for safety reasons
- COND. RUN            Conditional RUN state. A condition has been set in the debugger (RUN until...), which has not yet been met
- STOP                    The STOP state occurs in the following cases:
  - Programming device in PGU mode connected when the CPU was switched on
  - PGU stopped by programming device
  - Condition for a COND.RUN has been met
- HALT                    The HALT state occurs in the following cases:
  - HALT instruction processed
  - Serious error in user program
  - Hardware fault
  - No program loaded
  - No communication module on a S-Bus PGU or Gateway Master port
- RESET                    The RESET state has the following causes:
  - Supply voltage too low
  - Firmware not starting up



### 3.12 Pin Configuration PCD1

Situation of sockets and screw terminal blocks on PCD1

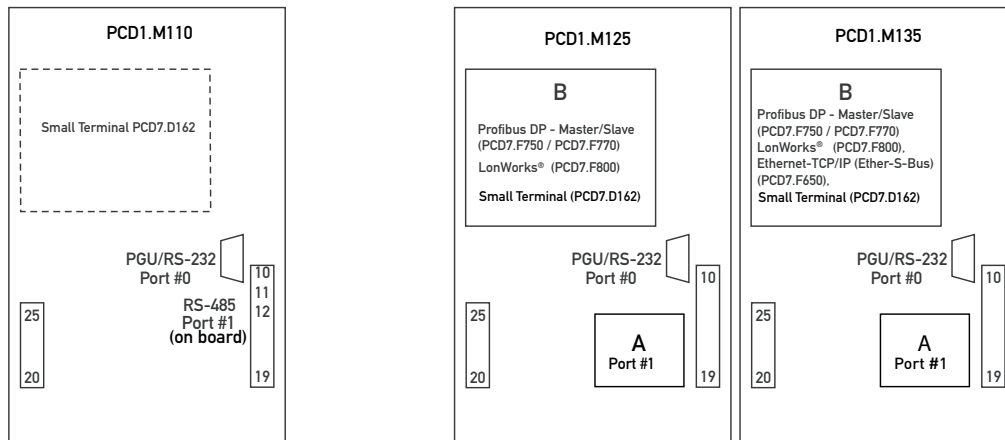

Supply/Interrupts		Optional serial data ports, socket A, Port #1 (Screw terminal block)							
Pin	Signal	Pin	RS-485 <sup>2)</sup>	RS-422	RS-232	TTY/20 mA	RS-485 <sup>3)</sup>	MP-Bus	
20...25		10...19	PCD7.F110	PCD7.F110	PCD7.F120	PCD7.F130	PCD7.F150	PCD7.F180	
20	+24V	10	PGND	PGND	PGND	PGND	PGND	PGND	
21	+24V	11	RX-TX	TX	TXD	TS	RX-TX	MP	
22	PGND	12	/RX-/TX	/TX	RXD	RS	/RX-/TX	,MFT'	
23	PGND	13	-	RX	RTS	TA	-	,IN'	
24	INB2 <sup>1)</sup>	14	-	/RX	CTS	RA	-	,GND'	
25	INB1 <sup>1)</sup>	15	PGND	PGND	PGND	PGND	PGND	PGND	
		16	-	RTS	DTR	TC	-		
		17	-	/RTS	DSR	RC	-		
		18	-	CTS	RSV	TG	SGND		
		19	-	/CTS	DCD	RG	-		

<sup>1)</sup> Not valid for the PCD1.M110

<sup>2)</sup> Also valid for the built-in RS-485 interface of PCD1.M110

<sup>3)</sup> galvanically isolated

PGU/RS-232, Port #0 see table PCD2

#### Moduls at socket B

##### Profibus DP and LonWORKS®

The bus should be connected directly to the PCD7.F7x0 module.

Connection can be achieved via screw terminal blocks. For details see manuals 26/737, 26/742, 26/765, 26/767

##### Ethernet-TCP/IP module

Ethernet-TCP/IP as configured system PCD1.M135F655 (with special cover no. 4 104 74090).

Connection can be achieved via RJ45 plug of category 5. For details see manual 26/776

### 3.13 Pin Configuration PCD2

Situation of sockets and screw terminal blocks on PCD2

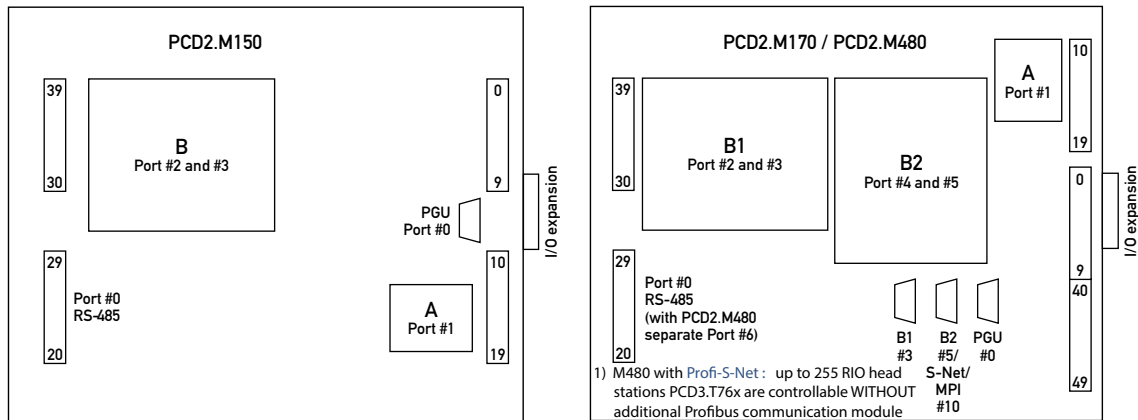

3

Supply/WD Port #0/#6, RS-485		Optional serial data ports on socket A, Port #1, Screw terminal block							Interrupt/counter (On board)		
Pin	Signal	Pin	RS-485 PCD7. F110	RS-422 PCD7. F110	RS-232 PCD7. F120	TTY/20 mA PCD7. F130	RS-485* PCD7. F150	MP-Bus PCD7. F180	Pin	Signal	PCD2. M480
20	+24V	10	PGND	PGND	PGND	PGND	PGND	PGND	0	INA1	IN0
21	+24V	11	RX-TX	TX	TXD	TS	RX-TX	MP	1	INB1	IN1
22	+24V	12	/RX-/TX	/TX	RXD	RS	/RX-/TX	,MFT'	2	INA2	IN2
23	PGND	13	-	RX	RTS	TA	-	,IN'	3	INB2	IN3
24	PGND	14	-	/RX	CTS	RA	-	,GND'	4	OUT1	OUT4
25	WD	15	PGND	PGND	PGND	PGND	PGND	PGND	5	OUT2	OUT5
26	WD	16	-	RTS	DTR	TC	-	-	6	+	+
27	PGND	17	-	/RTS	DSR	RC	-	-	7	L	L
28	/D	18	-	CTS	RSV	TG	SGND	-	8	PGND	PGND
29	D	19	-	/CTS	DCD	RG	-	-	9	PGND	PGND

\* galvanically isolated

Port #	B/B1 Pin	B2 Pin	RS-232 + RS-485 PCD2.F520/F530	RS-485, PCD7.F772/F802	RS-232 + RS-422 PCD2.F520/F530	2xRS-232 PCD2.F522	RS-232 full PCD2.F522
Port #2/4	30	40	PGND	PGND	PGND	PGND	PGND
	31	41	TXD	RX - TX	TXD	TXD	TXD
	32	42	RXD	/RX - /TX	RXD	RXD	RXD
	33	43	RTS	-	RTS	RTS	RTS
Port #3/5	34	44	CTS	-	CTS	CTS	CTS
	35	45	PGND	-	PGND	PGND	PGND
	36	46	RX - TX	-	TX	TXD	DTR
	37	47	/RX - /TX	-	/TX	RXD	DSR
	38	48	-	-	RX	RTS	-
	39	49	-	-	/RX	CTS	DCD

D-Sub, Pin	On board	Optional serial ports on sockets B1 and B2, 9 pole D-Sub connector					S-Net/MPI
	Port #0 PGU RS-232	Optional Ports #3 and #5					Port #10 <sup>1)</sup> with PCD2.M480 only (instead of B2)
1	PGND	RS-232 PCD2.F522	RS-422 PCD2.F520/F530	RS-485 PCD2.F520/F530	Profibus	LONWORKS®	not used
2	RXD	PGND	PGND	PGND	PGND	PGND	M24V
3	TXD	RXD	/TX	/RX - /TX	RXD/TXD-P	LON A	RXD/TXD-P <sup>2)</sup>
4	-	-	-	-	CNTR-P/RTS	-	CNTR-P <sup>2)</sup>
5	GND	RTS	RX	-	GND	LON GND	DGND <sup>2)</sup>
6	DSR	CTS	/RX	-	+5V	-	VP <sup>2)</sup>
7	RTS	-	-	-	-	-	P24
8	CTS	TXD	TX	RX - TX	RXD/TXD-N	LON B	RXD/TXD-N <sup>2)</sup>
9	+5V	-	-	-	-	-	not used

For details see manual 26/737 <sup>1)</sup> Profi-S-IO: up to 255 PCD3.T76x are controllable W/O Profibus modules

<sup>2)</sup> obligatory

### 3.14 Expansion of user memory

#### 3.14.1 Basics

The main reasons to expand the user memory for a PCD1/PCD2 are:

- The base memory is too small to store the user program and the texts
- The user program and the non-modifiable texts and data blocks are to be held in Flash EPROM as a failsafe measure (the base memory is always RAM)
- The benefits of data blocks with addresses  $\geq 4000$  are to be used:
  - up to 16,384 elements / DBs
  - much lower overhead per element: 4 bytes per 32-bit value rather than 8 bytes
  - much faster access



The **PCD2.M170** and **PCD2.M480** are equipped with 1 Mbyte of RAM as standard; this cannot be expanded. To minimize the risk of program loss, we recommend the use of the optional PCD7.R400 flash card, which allows the user program to be backed up.

The use of EPROMs to expand the user memory is obsolete and is no longer recommended. Working with Flash EPROMs is much more convenient (no EPROM programming device required, behaves like RAM for the programmer) and just as secure as EPROMs.

#### 3.14.2 Memory location of the user program, the resources, texts and DBs

Depending on whether the user memory of a PCD1/PCD2 has been expanded or not, the memory location of various parts of the application will vary. When the user memory is expanded by plugging in a memory chip, the user program and the text strings/DBs with addresses  $< 4000$  are stored in the additional plug-in chip.

The base memory provided on the CPU is then free, and can optionally be defined in the hardware configuration as “extension memory” and used to store texts and DBs with addresses  $\geq 4000$ .

Memory location Contents	No expansion of user memory	With expansion of user memory
Resources (registers, flags, counters etc.)	The resources are held in a separate RAM memory on the CPU (always in the same location, buffered by the SuperCap or the battery)	
User program	in <b>base memory</b>	in additional chip in “ <b>USER PROG</b> ” socket <sup>1)</sup>
Texts and DBs with addresses $< 4000$	in <b>base memory</b>	in additional chip in “ <b>USER PROG</b> ” socket <sup>1)</sup>
Texts and DBs with addresses $\geq 4000$	<u>not available</u>	in <b>extension memory</b> <sup>2)</sup>

1) i.e. in RAM, EPROM or Flash EPROM depending on the chip used. The use of EPROM is no longer recommended; use Flash EPROM instead

2) Must be defined in the hardware configuration

#### 3.14.3 Example of a memory configuration

The screenshots below show examples of the hardware configuration and associated software settings in PG5 for a PCD2.M120 (hardware version  $\geq J$ ) with a 1 Mbit Flash EPROM plug-in expansion unit (item-no. 4 502 7141 0).

Extension memory is configured and is used to hold RAM texts and RAM DBs.

### Step 1: Hardware configuration

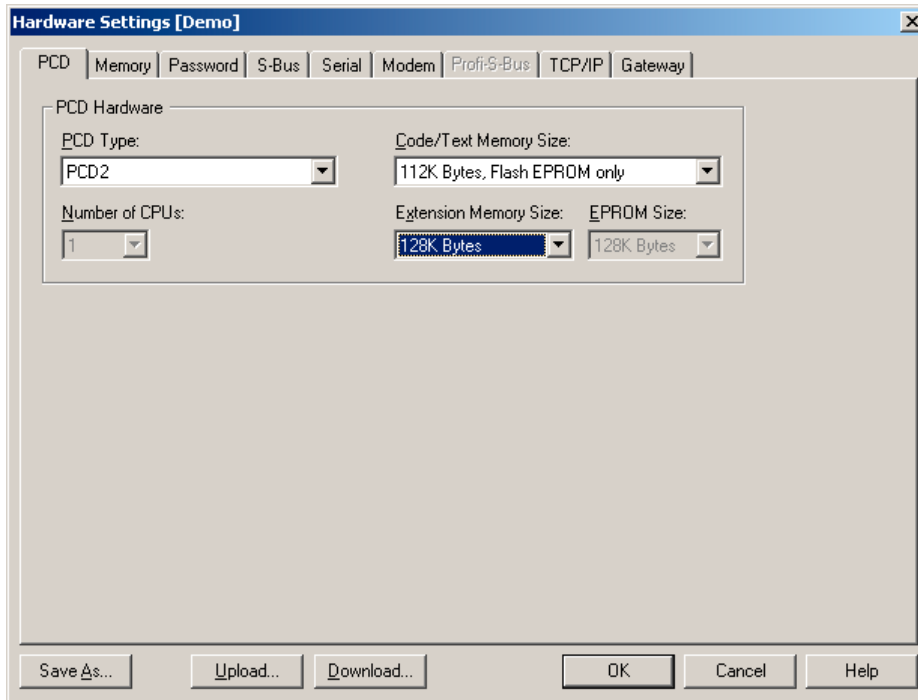

In this example, only 112 Kbytes of Flash EPROM are available as code/text memory (on the plug-in chip); one block of memory is lost to configuration data (header), because Flash EPROM can only be accessed in block mode.

For a PCD2.M110/M120 with hardware version < J, only 24 Kbytes of extension memory (onboard memory) can be configured; previously, less base memory was provided with these CPU types.

### Step 2: Downloading the hardware configuration

### Step 3: Modifying system settings

Software settings before modification:

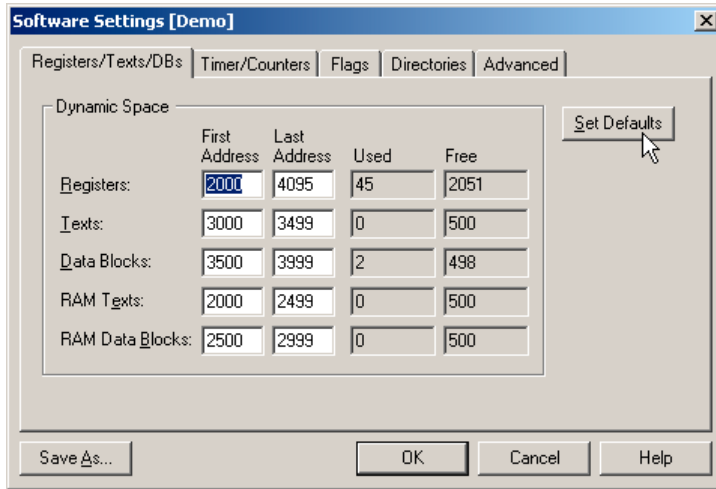

3

After modification ("Set defaults" pressed):

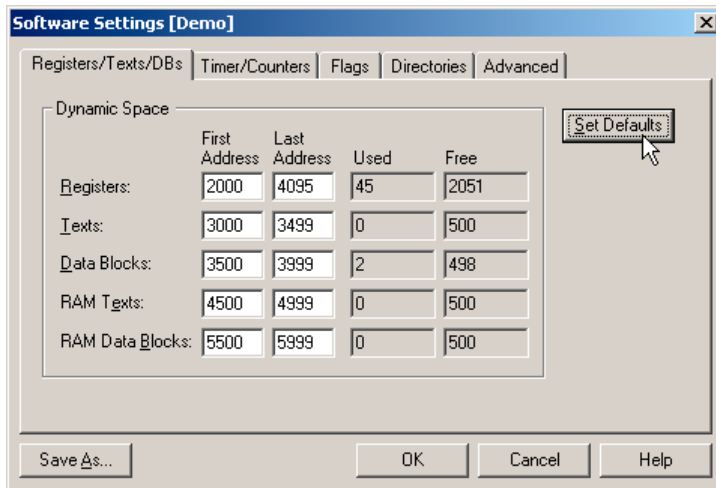

The addresses of the RAM text strings and DBS have been changed.

The "Set Defaults" button is useful in many cases, as the addresses are automatically set according to the hardware configuration. However, the previous settings are lost.

The new software settings are picked up at the next build.

### 3.14.4 PCD1.M1x0

The user memory for PCD1 CPUs can be expanded with RAM, EPROM and, from firmware version 002, with Flash EPROM, **up to a maximum of 1 Mbit**.

The base memory thus released can be configured as extension memory and used to hold 13 Kbytes of texts and DBs.

As the price differences between the different memory chips are very small, we recommend the use of the following types:

Memory type	Item-no.	Typical codes	Size
RAM	4 502 7013 0 <sup>1)</sup>	BS62LV1025 PC-70 LP621024D-70LL SRM20100LLC70 HY628100ALP-70 GM76C8128CLL-70 MEL M5M51008BP-70L	1 Mbit / 128 Kbytes
EPROM <sup>2)</sup>	4 502 7126 0	AM27C010-90 DC NM27C01Q-90 M27C1001-10F1	1 Mbit / 128 Kbytes
Flash EPROM <sup>3)</sup>	4 502 7141 0	AM29F010-70PC	1 Mbit / 112 Kbytes <sup>4)</sup>

1) Where RAM components not approved by SBC are used, there is a risk of losing data

2) The use of EPROMs is obsolete; use Flash EPROM instead

3) Flash EPROM is supported from firmware version 002 only

4) To hold the configuration, a portion of memory is lost, so for this chip, 112 Kbytes rather than 128 are available to the user

The following chips will work, but are no longer recommended for new installations:

Memory type	Item-no.	Typical codes	Size
RAM	4 502 5414 0 <sup>1)</sup>	SRM2B256LCX70 HY62256ALP-70 GM76C256CLL-70 MEL M5M5256DP-70LL TC55257DPL-70L	256 Kbits / 32 Kbytes
EPROM <sup>2)</sup>	4 502 3958 0	AM27C512-90 DC UPD27C512D-10 M27C512-10XF1 M27C512-10F1	512 Kbits / 64 Kbytes

**Steps in the correct installation of extended user memory:**

- 1) Switch off power supply and remove the cover of the PCD1
- 2) Plug the additional memory chip into the “USER PROG” socket.  
Ensure correct alignment (markings on the socket and the chip must match), and ensure that all pins on the chip are inserted into the socket
- 3) Set the jumper next to the socket correctly:

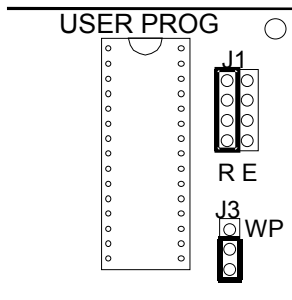

Jumper		Position
J1 (memory type)	RAM EPROM Flash EPROM	R <sup>1)</sup> E E
J3 (write-protection)	Write protection for <u>extension memory</u> <b>deactivated</b> Write protection for <u>extension memory</u> <b>activated</b> (only works with RAM and Flash EPROM)	beneath <sup>1)</sup> WP (up)

1) Jumper position on delivery: RAM, write protection deactivated

- 4) Modify the hardware configuration in PG5 accordingly, and download the new configuration

### 3.14.5 PCD1.M125 and PCD1.M135

The user memory for these CPUs can be expanded as follows :

CPU Typ	Expansion option	Available memory for extension memory <sup>1)</sup>
PCD1.M1x5	RAM: 512 KBit / 128 KByte EPROM: 128 KBit / 128 KByte Flash-EPROM: 448 KBit / 112 KByte	128 KByte 128 KByte 128 KByte

1) The base memory released by the extended memory can be configured as extension memory and used to store texts and DBs

As the price differences between the different memory chips are very small, we recommend the use of the following types:

Memory type	Item-no.	Typical codes	Size
RAM	4 502 7013 0 <sup>1)</sup>	BS62LV1025 PC-70 LP621024D-70LL SRM20100LLC70 HY628100ALP-70 GM76C8128CLL-70 MEL M5M51008BP-70L	1 Mbit / 128 Kbytes
	4 502 7175 0 <sup>1)</sup>	HM628512LP-5 KM684000BLP-SL K6T4008C1B-DB55	4 Mbits / 512 Kbytes
EPROM <sup>2)</sup>	4 502 7126 0	AM27C010-90 DC NM27C01Q-90 M27C1001-10F1	1 Mbit / 128 Kbytes
Flash EPROM <sup>3)</sup>	4 502 7141 0	AM29F010-70PC	1 Mbit / 112 Kbytes <sup>3)</sup>
	4 502 7224 0	SBE29F040 AM29F040B-90PC	4 Mbits / 448 Kbytes <sup>3)</sup>

1) Where RAM components not approved by SBC are used, there is a risk of losing data

2) The use of EPROMs is obsolete; use Flash EPROM instead

3) To hold the configuration, a portion of memory is lost, so for this chip, 112 Kbytes rather than 128 are available to the user



**Steps in the correct installation of extended user memory:**

- 1) Switch off power supply and remove the cover of the PCD1
- 2) Plug the additional memory chip into the "USER PROG" socket.  
Ensure correct alignment (markings on the socket and the chip must match), and ensure that all pins on the chip are inserted into the socket
- 3) Set the jumper next to the socket correctly:

3

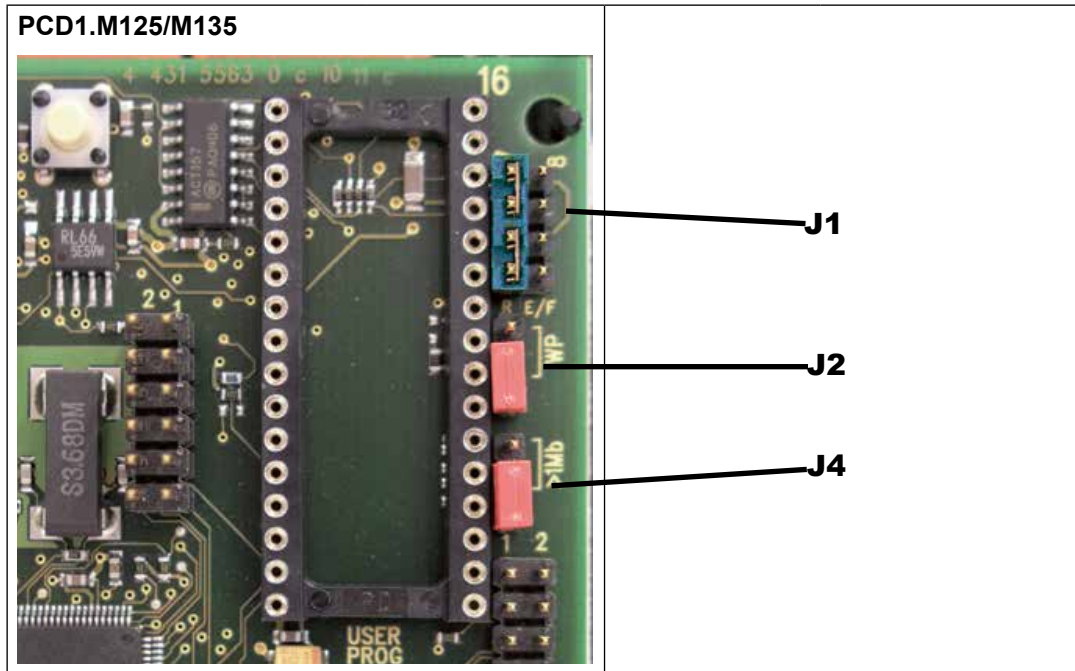

Jumper		Position
J1 (Memory type)	RAM EPROM Flash-EPROM	left; <b>R</b> <sup>1)</sup> right; <b>E/F</b> right; <b>E/F</b> <sup>2)</sup>
J2 (write-protection)	Write protection <b>activated</b> <sup>2)</sup> (only works for RAM and Flash-EPROM) Write protection <b>deactivated</b> <sup>2)</sup>	up; <b>WP</b> <sup>1)</sup> down
J4 (memory size <= 1 MBit or > 1 MBit)	Memory size > 1 MBit Memory size <= 1 MBit	up <sup>1)</sup> ; <b>&gt;1MB</b> down

1) Jumper position on delivery: RAM, write-protection deactivated, memory size ≤ 1 Mbit

2) Write-protection only affects the chip in the USER PROG socket

- 4) Modify the hardware configuration in PG5 accordingly, and download the new configuration

**3.14.6 PCD2.M110/M120/M150**

The user memory for these CPUs can be expanded as follows:

CPU type	HW-version	Basic equipment RAM:	FW-version	Expansion option (max.)	Available memory for extension memory <sup>1)</sup>
PCD2.M150	all	128 KByte		RAM: 4 MBit / 512 KByte EPROM: 4 MBit / 512 KByte Flash-EPROM: 4 MBit / 448 KByte	128 KByte 128 KByte 128 KByte
PCD2.M110/ M120	> H	32 KByte	≥ 080	RAM: 4 MBit / 512 KByte EPROM: 4 MBit / 512 KByte Flash-EPROM: 4 MBit / 448 KByte	128 KByte 128 KByte 128 KByte
			≥ 006	RAM: 4 MBit / 512 KByte EPROM: 4 MBit / 512 KByte Flash-EPROM: 4 MBit / 448 KByte	6 KByte 6 KByte 6 KByte
PCD2.M110/ M120	H	32 KByte	≥ 080	RAM: 4 MBit / 512 KByte EPROM: 4 MBit / 512 KByte Flash-EPROM: 4 MBit / 448 KByte	128 KByte 128 KByte 128 KByte
			≥ 006	RAM: 4 MBit / 512 KByte EPROM: 4 MBit / 512 KByte Flash-EPROM: 4 MBit / 448 KByte	6 KByte 6 KByte 6 KByte
PCD2.M110/ M120	≥ C	32 KByte	≥ 080	RAM: 1 MBit / 128 KByte EPROM: 1 MBit / 128 KByte Flash-EPROM: 1 MBit / 128 KByte	24 KByte 24 KByte 24 KByte
			< 080	RAM: 1 MBit / 128 KByte EPROM: 1 MBit / 128 KByte Flash-EPROM: 1 MBit / 128 KByte	6 KByte 6 KByte 6 KByte

1) The base memory released by the extended memory can be configured as extension memory and used to store texts and DBs

As the price differences between the different memory chips are very small, we recommend the use of the following types:

Memory type	Item-no.	Typical codes	Size
RAM	4 502 7013 0 <sup>1)</sup>	BS62LV1025 PC-70 LP621024D-70LL SRM20100LLC70 HY628100ALP-70 GM76C8128CLL-70 MEL M5M51008BP-70L	1 Mbit / 128 Kbytes
	4 502 7175 0 <sup>1)</sup>	HM628512LP-5 KM684000BLP-SL K6T4008C1B-DB55	4 Mbits / 512 Kbytes
EPROM <sup>2)</sup>	4 502 7126 0	AM27C010-90 DC NM27C01Q-90 M27C1001-10F1	1 Mbit / 128 Kbytes
	4 502 7223 0	AM27C040-100DC M27C4001-10F1	4 Mbits / 512 Kbytes
Flash EPROM <sup>3)</sup>	4 502 7141 0	AM29F010-70PC	1 Mbit / 112 Kbytes <sup>4)</sup>
	4 502 7224 0	SBE29F040 AM29F040B-90PC	4 Mbits / 448 Kbytes <sup>4)</sup>

1) Where RAM components not approved by SBC are used, there is a risk of losing data

2) The use of EPROMs is obsolete; use Flash EPROM instead

3) Flash EPROM is supported from firmware version 002 only

4) To hold the configuration, a portion of memory is lost, so for this chip, 112 Kbytes rather than 128 are available to the user

The following chips will work, but are no longer recommended for new installations:

Memory type	Item-no.	Typical codes	Size
RAM	4 502 5414 0 <sup>1)</sup>	SRM2B256LCX70 HY62256ALP-70 GM76C256CLL-70 MEL M5M5256DP-70LL TC55257DPL-70L	256 Kbits / 32 Kbytes
EPROM <sup>2)</sup>	4 502 3958 0	AM27C512-90 DC UPD27C512D-10 M27C512-10XF1 M27C512-10F1	512 Kbits / 64 Kbytes

**Steps in the correct installation of extended user memory:**

- 1) Switch off power supply and remove the cover of the PCD2
- 2) Plug the additional memory chip into the “USER PROG” socket.  
Ensure correct alignment (markings on the socket and the chip must match), and ensure that all pins on the chip are inserted into the socket
- 3) Set the jumper next to the socket correctly:

PCD2.M110/M120 hardware version ≥ H and PCD2.M150		PCD2.M110/M120 hardware version < H	
Jumper		Position	
J1 (memory type)	RAM EPROM Flash EPROM	R <sup>1)</sup> E F <sup>2)</sup>	
J3 (write-protection)	Write protection <b>deactivated</b> <sup>3)</sup> Write protection <b>activated</b> <sup>3)</sup> (only works for RAM and Flash EPROM)	up <sup>1)</sup> WP (down)	
J5 (memory size ≤ 1 Mbit or > 1 Mbit) <sup>2)</sup>	Memory size ≤ 1 Mbit Memory size > 1 Mbit	up <sup>1)</sup> down	

- 1) Jumper position on delivery: RAM, write-protection deactivated, memory size ≤ 1 Mbit
- 2) On the PCD2.M110/M120 with hardware version < H, J5 and the J2 F jumper are not present. This means that where Flash EPROM is used with these controllers, J2 has to be attached to E and only chips up to 1 Mbit can be used for expansion
- 3) Write-protection only affects the chip in the USER PROG socket
- 4) Modify the hardware configuration in PG5 accordingly, and download the new configuration

### 3.15 Partitioning options for user memory

In the PG5 hardware configuration, the user memory is partitioned by default into lines of code and texts/DBs, in a way that suits most applications.

In the case of a large program with few texts/DBs or a very small program with many texts/DBs, the user can partition the memory manually. In order to choose an appropriate breakdown, the following should be noted:

- the partitioning is into “Kbytes lines of code” and “Kbytes text/DBs”, where the “Kbytes lines of code” can only be changed in 4 Kbytes steps, as every line of code occupies 4 bytes
- the result of the formula (4 × “Kbytes lines of code”) + “Kbytes text/DBs” must equal the available user memory, e.g. 4 × 24 Kbytes + 32 Kbytes = 128 Kbytes
- each character of a text occupies 1 byte
- each 32-bit element of a DB occupies eight bytes in the address range 0..3999, and the header of the DB takes up a further three bytes
- PCD1, PCD2.M110/M120/M150:  
For applications with many DBs, we recommend fitting a memory expansion unit, so that extension memory can be configured. The DBs with addresses from 4000 that can be held there can hold more elements (16384 instead of 384), take up less space (only 4 bytes instead of 8 bytes per element, but NB, 8 bytes instead of 3 for the header) and the access time is substantially shorter. The extension memory is independent of the memory partitioning and is only configurable where an expansion unit is plugged in
- PCD2.M170/M480:  
We recommend that DBs with addresses ≥ 4000 should always be used. The addresses from 4000 that can be held there can hold more elements (16384 instead of 384), take up less space (only 4 bytes instead of 8 bytes per element, but NB, 8 bytes instead of 3 for the header) and the access time is substantially shorter.

3

Example of manual partitioning of a PCD2.M150:

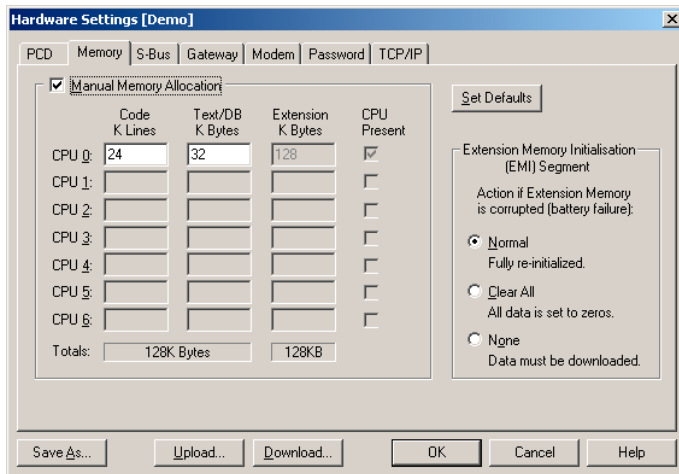

**3.16 Data storage in case of power outage**

The resources (registers, flags, timers, counters etc), and possibly the user program and the text strings/DBs, are stored in RAM. To ensure that they are not lost and that the hardware clock (where present) continues to run when there is a power outage, the PCD1/PCD2 are equipped with a buffer capacitor (SuperCap) or a buffer battery.

CPU type	Buffer	Buffer time
PCD1.M110	Super Cap (soldered)	30 days <sup>1)2)</sup>
PCD1.M120/M125	Super Cap (soldered)	7 days <sup>2)</sup>
PCD1.M130/M135	CR 2032 lithium battery	1-3 years <sup>3)</sup>
PCD2.M110/M120 hardware version < H	2 × alkaline batteries size LR03/AAA/AM4/Micro	1-5 years <sup>3)</sup>
PCD2.M110/M120 hardware version >= H	CR 2032 lithium battery	1-3 years <sup>3)</sup>
PCD2.M150/M170/M480	CR 2032 lithium battery	1-3 years <sup>3)</sup>

1) The PCD1.M110 has no hardware clock, so the buffer time is greater than it is for the PCD1.M120  
 2) The total load time of the PCD1.M110, PCD1.M120 and PCD1.M125 amounts to approx. 30 minutes  
 3) Depending on the ambient temperature; the higher the temperature, the shorter the buffer time



With new controllers, the batteries are packaged with the units, and have to be inserted on commissioning. Observe the polarity of the batteries:

- for alkaline batteries, the polarity can be seen on the socket
- insert CR2032 coin cell in such a way that the Plus pole is visible

CPUs with alkaline or lithium batteries are not maintenance-free. The battery voltage is monitored by the CPU. The BATT LED lights up and XOB 2 is called if:

- the battery voltage is below 2.4 V or above 3.5 V
- the battery is flat or shows an interrupt
- the battery is missing

We recommend changing the batteries with the Saia PCD® attached to the power supply, to avoid any loss of data.

The batteries are easy to locate on all CPU types.

PCD1.M130:



PCD1.M135:



PCD2.M110/120/150:

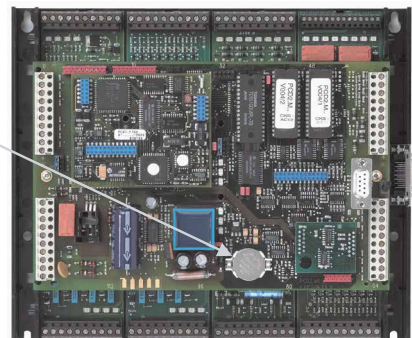

On the PCD2.M170 and M480 the whole cover does not have to be removed; it is sufficient to open the battery compartment on the side to gain access to the battery.

PCD2.M170/480:

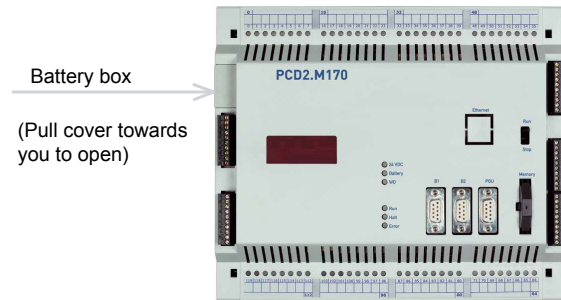

### 3.17 Backup of the user program (flash card for PCD2.M170/M480)

#### 3.17.1 General

The PCD2.M170 and PCD2.M480 are equipped with 1 MByte of RAM as standard and can be fitted with an optional PCD7.R400 flash card. The flash card makes it possible to save a failsafe copy of the application after downloading (code, text/DBs and extension memory).

We recommend fitting all PCD2.M170 and M480 units with the flash card, to avoid any accidental loss of data.



Even with backup to the flash card, the source files for the project must be retained, as the application is only stored in the Saia PCD® as machine code.

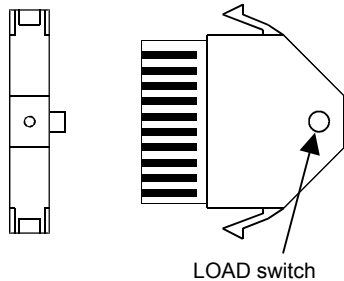

It is also possible to use the flash card to transfer applications from one controller to another, and to create a backup of RAM texts and DBs in extension memory (address  $\geq 4000$ ) while the controller is in operation.



The flash card must not be plugged in or removed while the unit is switched on.

If it transpires when the PCD2.M170/M480 is started up that one of the RAM memories has been corrupted (e.g. after a power outage with a flat or missing battery), the application is automatically copied to the Saia PCD®.

### 3.17.2 Copying the application to the flash card (backup)

In PG5, an option can be set so that the complete user program (code, text strings/DBs and extension memory) is copied to the flash card after every download. This can be found in the Project Manager, under Tools, Options, Download:

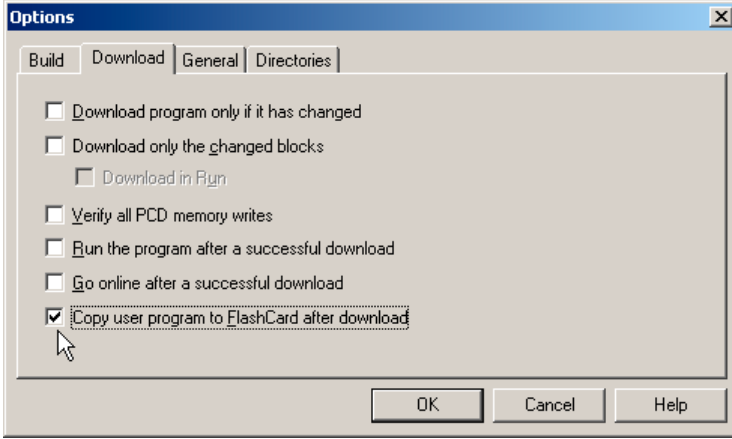

3

The same option window can be called up when downloading, as follows:

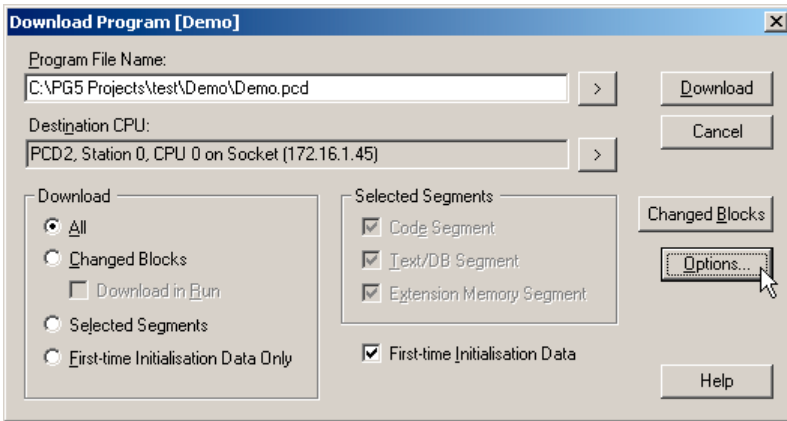



It is also possible to copy the application to the flash card independently of any download, or conversely, to copy the application from the flash card to the Saia PCD®. The relevant menu options can be found under Online, Flash Card:

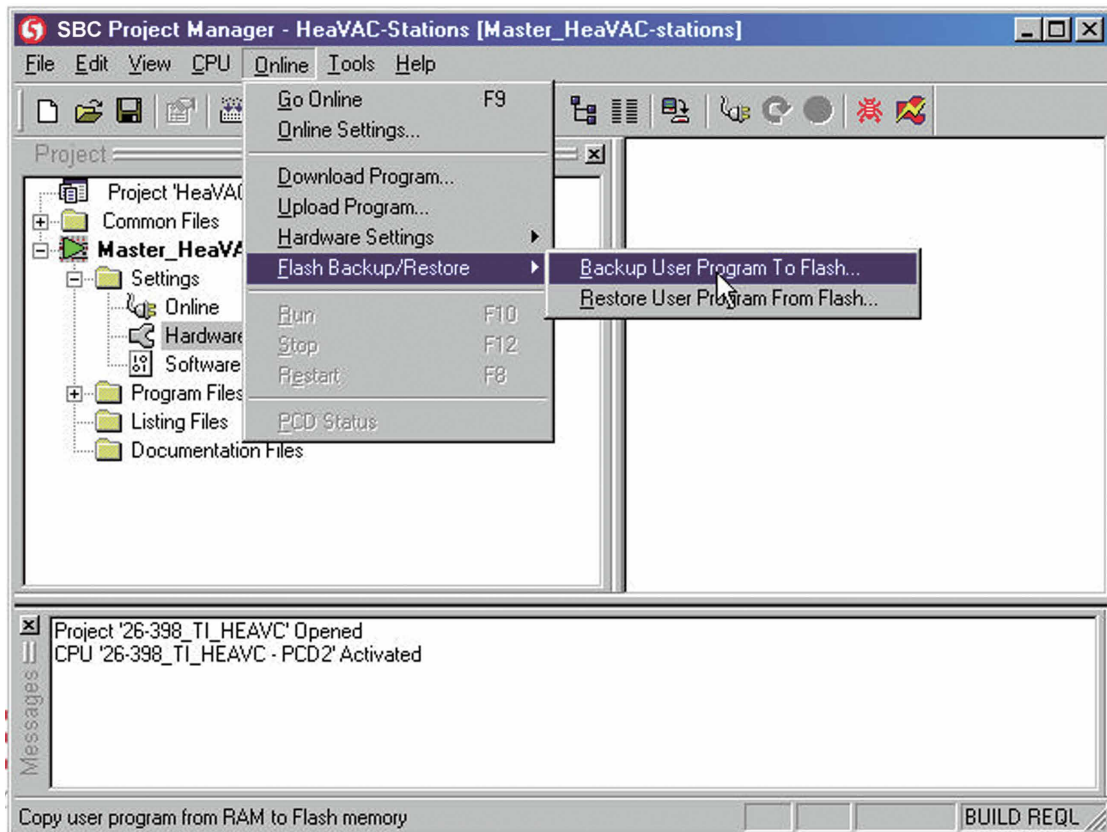

3



Before copying, the controller must be moved into the STOP state; where applicable, an appropriate reminder will be displayed. The copying process may take up to 30 seconds.

### 3.17.3 Transferring an application

With the flash card, it is possible to transfer an application from a PCD2.M170/M480 to another controller of the same type:

- On the source controller, copy the application to the flash card as described in the preceding sections
- Remove the supply to the source controller, and unplug the flash card
- Send off the flash card where applicable
- Ensure that there is no supply voltage to the target controller, then plug in the flash card
- Switch on the supply to the target controller, then hold down the LOAD switch on the flash card for at least three seconds; this can be done at any time
- Wait until the controller has restarted

**3.17.4 Backup/restore of RAM texts/DBs at run-time**

As described above, the application can be copied to the flash card after downloading. In order to store process data gathered during operation, there is a facility to copy texts or DBs from extension memory (address >= 4000) to the flash card, or conversely, to copy the last state written to the flash card back in the text/DB in extension memory. A maximum of 64 Kbytes are available for this.

In order to use this function, the option shown below must be activated in the hardware configuration and the configuration must be loaded into the controller.

3

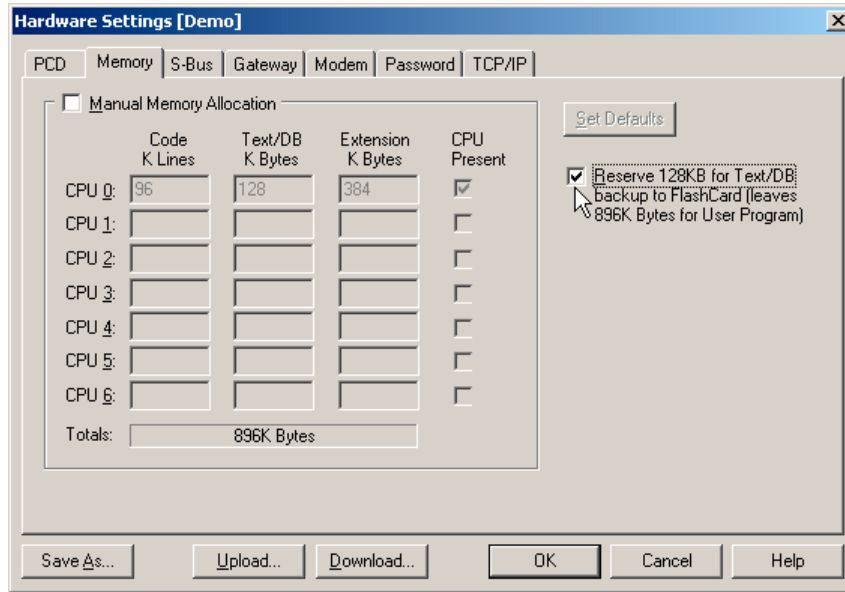

This leaves only 896 Kbytes available for the whole application (code, texts/DBs and extension memory).

For storing texts/DBs on the flash card, restoring, deleting and running diagnostics, there are four SYSRD/SYSWR instructions provided, as described in detail below; these can be invoked at a suitable place in the user program. These instructions must be used with great care, to prevent any damage to the unit or the flash card.

**Storing a text/DB on the flash card, SYSWR K 9000**

Instruction:

<b>SYSWR</b>	<b>K 9000<sup>1)</sup></b>	
	<b>K number</b>	; address of the texts/DBs as ; K constant or in a ; register, existing text/DB addresses in ; the range >= 4000 may be used
1) Alternatively, the value 9000 can be passed in a register. On the PCD3, the instruction SYSWR K 3000 is used for the same function. For reasons of compatibility, SYSWR K 3000 can also be used on the PCD1/2, but this alternative was only integrated into the firmware in the 2nd half of 2004		

3

Accu status after execution:

low:	the text/DB has been saved, and the flash card is ready for new SYSWR instructions
high:	the last instruction was not processed to completion; before further SYSWR K 900x instructions, a SYSRD K 9000 must be executed to check the readiness of the flash card



When using the instruction SYSWR K 9000, note the following:

- The flash card can be written to a maximum of 100'000 times, so it is not permissible to invoke the instruction in a cyclical manner or at short intervals
- A SYSRD K 9000 must be executed before this instruction, to test whether the flash card is available and ready
- the processing time for the instruction may be up to 100 ms. At that point, there is no guarantee that all of the text/DB has been written (the process will continue in background). For this reason, the instruction must not be invoked in XOB 0 (XOB for a power outage) or during time-critical processes
- if errors occur during processing, e.g. because no flash card is plugged in, XOB 13 will be invoked (where present), or the Error LED will be set
- when starting the Saia PCD® after a loss of RAM memory, the state of the texts/DBs after the last download is restored, even where the SYSWR K 9000 instruction has been used to store newer versions.
- Within the maximum number of write cycles, a text/DB can be stored any number of times, without the flash card becoming over-full.

**Restoring a text/DB, SYSWR K 9001**

Instruction:

<b>SYSWR</b>	<b>K 9001<sup>1)</sup></b>	
	<b>K number</b>	; address of the texts/DBs as ; K constant or in a ; register, existing text/DB addresses in ; the range >= 4000 mAy be used
1) Alternatively, the value 9001 can be passed in a register. On the PCD3, the instruction SYSWR K 3001 is used for the same function. For reasons of compatibility, SYSWR K 3001 can also be used on the PCD1/2, but this alternative was only integrated into the firmware in the 2nd half of 2004		

3

Accu status after execution:

low:	the text/DB has been restored and the process is complete, so further SYSWR K 900x instructions can be executed immediately
high:	the last instruction has not yet processed to completion; before further SYSWR K 900x instructions, a SYSRD K 9000 must be executed to check the readiness of the flash card



When using the instruction SYSWR K 9001, note the following:

- A SYSRD K 9000 must be executed before this instruction, to test whether the flash card is available and ready
- If errors occur during processing, e.g. because no flash card is plugged in, XOB 13 will be invoked (where present), or the Error LED will be set

**Deleting stored texts/DBs on the flash card, SYSWR K 9002**

Instruction:	<b>SYSWR</b>	<b>K 9002<sup>1)</sup></b>	
		<b>K 0</b>	; Dummy parameter, required to ; maintain the structure of the SYSWR ; instruction
1) Alternatively, the value 9002 can be passed in a register. On the PCD3, the instruction SYSWR K 3002 is used for the same function. For reasons of compatibility, SYSWR K 3002 can also be used on the PCD1/2, but this alternative was only integrated into the firmware in the 2nd half of 2004			

3

Accu status after execution:

low:	The text strings/DBs have been deleted and the process is complete, so further SYSWR K 900x instructions can be executed immediately
high:	The last instruction has not yet processed to completion; before further SYSWR K 900x instructions, a SYSRD K 9000 must be executed to check the readiness of the flash card



When using the instruction SYSWR K 9002, note the following:

- The deletion only affects text/DBs previously stored with SYSWR K 9000. The contents of the extension memory stored after a download are retained
- A SYSRD K 9000 must be executed before this instruction, to test whether the flash card is available and ready
- The processing time for the instruction may be several 100 ms. For this reason, the instruction must not be invoked in XOB 0 (XOB for a power outage) or during time-critical processes
- If errors occur during processing, e.g. because no flash card is plugged in, XOB 13 will be invoked (where present), or the Error LED will be set

**Diagnostics on the flash card, SYSRD K 9000**

Instruction:	<b>SYSRD</b>	<b>K 9000<sup>1)</sup></b>	
		<b>R_Diag</b>	; Diagnostics register
1) Alternatively, the value 9000 can be passed in a register. On the PCD3, the instruction SYSRD K 3000 is used for the same function. For reasons of compatibility, SYSRD K 3000 can also be used on the PCD1/2, but this alternative was only integrated into the firmware in the 2nd half of 2004			

3

Accu status after execution:

low:	The flash card is ready, and SYSWR 900x instructions can be executed
high:	The Flash card is not available or not ready; the diagnostic register must be retrieved and the process retried later



When using the instruction SYSRD K 9000, note the following:

- If errors occur during processing, e.g. because no flash card is plugged in, XOB 13 will be invoked (where present), or the Error LED will be set

Specification of diagnostic register		
Bit	Description (if high)	Cause
0 (LSB)	No flash card	
1	Header not configured	No application on the flash card
2	No SYSWR access to flash card	The corresponding option has not been activated in the hardware configuration (reserved for text/DB etc.)
3	DB/text not present	In the last instruction, an incorrect DB/text number was used as a parameter
4	DB/text format invalid	The length of the DB or the text has been changed
5	Restored	Text/DB on the flash card has been restored, as an error occurred
6	Memory full	Too many texts/DBs, no more free memory space available
7	Already in progress	The last SYSWR 900x instruction had not yet been fully processed when the next was started
8...31	Spare	

### 3.18 Hardware clock (Real Time Clock)

Most PCD1/PCD2 CPUs are fitted with a hardware clock:

CPU type	Where is the hardware clock?
PCD1.M110	Not present, and cannot be fitted
PCD1.M120/M130	On the motherboard
PCD1.M125/M135	On the motherboard
PCD2.M110/M120 hardware version < H	On the optional PCD2.F5x0 Modules with hardware version A (while stocks last)
PCD2.M110/M120 hardware version >= H	On the motherboard. Old PCD2.W5x0 Modules can also be fitted with a hardware clock; in all cases, the clock on the motherboard is used
PCD2.M150/M170/M480	On the motherboard

3



The presence of a hardware clock is an absolute requirement where the HeaVAC library clock timers are used.

#### 3.18.1 Clock module PCD2.F500 (obsolete, PCD2.M110/M120 only)

On the PCD2.M110/M120 with hardware version < H, a PCD2.F5x0 Module with hardware clock (hardware version A) could be fitted where necessary.

The PCD2.F500 is a clock module without serial ports for socket B and allows a hardware clock to be added to old controllers. It is no longer obtainable.

### 3.19 Monitoring the CPU (watchdog)

The watchdog monitoring unit can be used to monitor the correct processing of the user program with a high level of reliability; in the event of errors, effective safety measures can be triggered, e.g. to switch off parts of the installation.

#### 3.19.1 PCD1 hardware watchdog

On the PCD1, this can be achieved with an external time relay (SBC KOP128j) with a timing range of 1 second. The time relay has a retriggerable drop-out delay; the B1 input to the time relay is connected to an output from the PCD1 (e.g. to an output from a PCD2.A400 card).

3

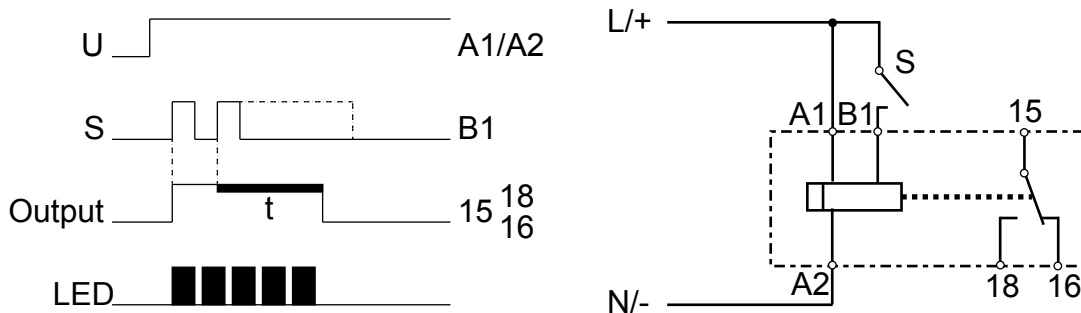

In Saia PCD® user programs, the output is set to flashing.

**Example:**

```

COB 0 ; or 1...15
      0
STL  WD_Flag ;Invert help flag
OUT  WD_Flag
OUT  O 255 ;Set output 255 to flashing
:
:
:
:
ECOB
    
```

With the code shown in the example, the watchdog drops out in the case of loops caused by the programmer. With regard to the cycle time of the user program, please note:

- With very short cycle times, the time relay may not be able to detect the pulse reliably
- With very long cycle times, either the code sequence must be repeated several times in the user program, or the drop-out time for the time relay must be set to a longer interval, to prevent drop-out of the watchdog in normal operation.



**3.19.2 PCD2 hardware watchdog**

PCD2 CPUs are fitted with a hardware watchdog as standard. A relay at I/O address 255 can be triggered; this remains activated as long as the status of O 255 changes periodically at least every 200 ms. Within PG5, FBoxes are provided for this purpose.

If for any reason the program component with the watchdog FBox is no longer being processed at sufficiently short intervals, the watchdog relay will drop out and the yellow watchdog LED will go out. Please read online help for more details on these FBoxes.



The same function can also be implemented with IL (AWL) instructions. There are various ways of doing this:

**Example:**

```

COB    0          ; or 1 ... 15
      0
STL    WD_Flag   ;Invert help flag
OUT    WD_Flag
OUT    O 255     ;Set output 255 to flashing
:      :
:      :
:      :
ECOB
    
```

With the code shown in example, the watchdog drops out in the case of loops caused by the programmer. With regard to the cycle time of the user program, please note:

- With cycle times of more than 200 ms, the code sequence must be repeated several times in the user program, to prevent a drop-out of the watchdog in normal operation.



As address 255 is in the normal I/O range, there are restrictions on the permissible I/O modules in certain sockets:

CPU type	Restrictions
PCD2.M110	none
PCD2.M120/M150	1) No analogue, counter and motion control modules on the socket with base address 240 2) Output 255 cannot be used for digital I/O modules either
PCD2.M170	1) No analogue, counter and motion control modules on the sockets with base addresses 240 and 496 2) Outputs 255 and 511 cannot be used for digital I/O modules either
PCD2.M480	1) No analogue, counter and motion control modules on the socket with base address 240 2) Output 255 cannot be used for digital I/O modules either

The status of the watchdog is displayed by the yellow "WD" LED:

- LED lit up: Relay closed
- LED not lit up: Relay dropped out

**Watchdog - connection diagram**

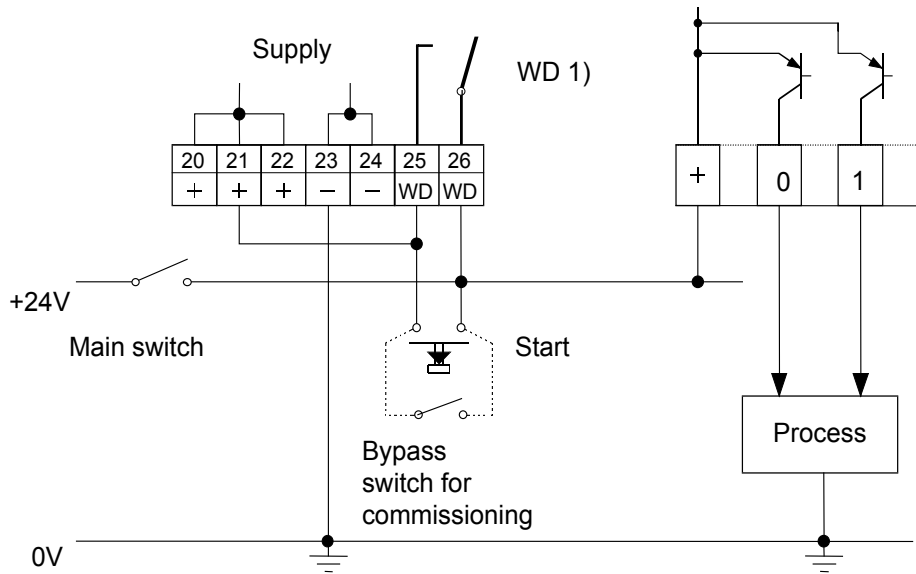

3

1) Switching capacity of the watchdog contact: 1 A, 48 VAC/DC

### 3.19.3 Software watchdog for PCD1 and PCD2

The hardware watchdog provides maximum security. However, for non-critical applications, a software watchdog may be sufficient, whereby the processor monitors itself and the CPU is restarted in the event of a malfunction or a loop.

The core of the software watchdog is the instruction SYSWR K 1000. When this is first issued, the software watchdog function is activated. This instruction must then be issued at least every 200 ms, or the watchdog will trigger and restart the controller.

Instruction:	<b>SYSWR</b>	<b>K 1000</b>	; Software watchdog instruction
		<b>R/K x</b>	; Parameters as per table below ; K constant or value in ; register
	x = 0	The software watchdog is deactivated	
	x = 1	The software watchdog is activated; if the instruction is not repeated within 200 ms, there is a cold start	
	x = 2	The software watchdog is activated; if the command is not repeated within 200 ms, XOB 0 will be called, followed by a cold start. XOB 0 calls are entered in the Saia PCD® history as follows:	
		"XOB 0 WDOG START"	where XOB 0 has been invoked by the software watchdog
	"XOB 0 START EXEC"	where XOB 0 has been invoked because of a supply fault	

In order to use the software watchdog, the following minimum firmware versions are required:

CPU type	Minimum firmware version
PCD1.M1x0	001
PCD1.M1x5	001
PCD2.M110/120	080
PCD2.M150	0B0
PCD2.M170	010
PCD2.M480	010



PCD2.M480: The status of the watchdog relay can be read via I 8107

"1" = watchdog relay on

**3.20 Internal LED displays and small terminals**

Outputs / communication interfaces can be used to connect external displays and terminals to all Saia PCD® CPUs. On the PCD1 and PCD2, it is also possible to attach such a user interface directly to the CPU.

**3.20.1 Outphased displays and small terminals**

Article	Active	Not recommended for new projects	Outphased (no longer produced)
PCD2.F510			x
PCD2.F520	x		
PCD2.F522	x		
PCD2.F530	x		
PCD7.D120			x
PCD7.D162	x		
PCD7.D163	x		
PCD7.D164	x		
PCD7.D165	x		

**3.20.2 PCD2.F510 7-segment LED display (PCD2.M110/M120/M150 only)**

The display consists of six 7-segment LED digits with decimal points, and is mounted on socket B. It is visible from outside through the window in the cover. The DSP instruction can be used to display the figures 0...9 and various other characters:

Examples:

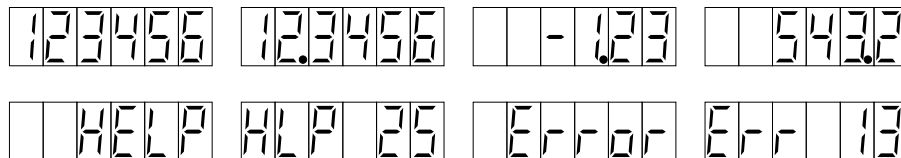

This integrated display can be easily used to show process states, error numbers, step numbers, dates and times, update information etc. By alternating the display or setting switches on inputs, several pieces of information can be displayed.

In the Fupla standard library, two FBoxes are provided under "Display", allowing convenient access to the display.

### The following programming rules apply for IL programming:

The display has three modes:

Mode	Properties
6-digit	The whole display is used to show a number (e.g. 123456) or one of the standard text strings (e.g. Error or HELP)
2-digit	The first four digits have been defined with a previous instruction (text, e.g. Err), and the last two digits can now be used to display a number
Free mode	Within the limitations of the 7-segment display, any character string can be displayed

3

The content of the display is managed with a DSP instruction. DSP instructions may be used with a constant (e.g. DSP K 0) or a register (e.g. DSP R 0) as a parameter.

The effect of the DSP K x instructions is independent of the mode in which they are invoked, but many of them do affect the mode:

In-struction		Display	Mode after instruction
DSP	K 0	The whole display is cleared and set to 6-digit mode	6-digit
DSP	K 1	≡ S A I A ≡	6-digit
DSP	K 2	≡ P C D 2 ≡	6-digit
DSP	K 3	HELP	6-digit
DSP	K 4 <sup>1)</sup>	H L P n n	2-digit
DSP	K 5	Error	6-digit
DSP	K 6 <sup>1)</sup>	E r r n n	2-digit
DSP	K 7 <sup>2)</sup>	The display is cleared and leading zeros are displayed from the next DSP R x instruction	6-digit
DSP	K 8 <sup>2)</sup>	The display is cleared and the output restricted to 2 digits	2-digit
DSP	K 10 <sup>2)</sup>	Places the decimal point at digit no. 0 (far right, cleared with DSP K 0)	no change
DSP	K 11 <sup>2)</sup>	Places the decimal point at digit no. 1 (cleared with DSP K 0)	no change
DSP	K 12 <sup>2)</sup>	In 6-digit mode, places the decimal point at digit no. 2 (cleared with DSP K 0)	no change
DSP	K 13 <sup>2)</sup>	In 6-digit mode, places the decimal point at digit no. 3 (cleared with DSP K 0)	no change
DSP	K 14 <sup>2)</sup>	In 6-digit mode, places the decimal point at digit no. 4 (cleared with DSP K 0)	no change
DSP	K 15 <sup>2)</sup>	In 6-digit mode, places the decimal point at digit no. 5 (far left, cleared with DSP K 0)	no change
DSP	K 20 <sup>3)</sup>	Switch to free mode	Free mode
DSP	K 21 <sup>3)</sup>	In free mode, all segments are moved one place to the left, a blank digit is inserted, and the previously leftmost digit is lost	Free mode

In-struction		Display	Mode after instruction
DSP	K 22 <sup>3)</sup>	Switch to free mode in 2-digit mode	2-digit

- 1) These instructions must be followed by a second DSP instruction in the format: DSP R x ; x = 0.. 4095. The register value must be 0.. 99. If the value is outside this range, nothing will be displayed and the error flag will be set
- 2) On the PCD2.M110/M120, available from firmware version 002 only
- 3) On the PCD2.M110/M120, available from firmware version 003 only

3

The effect of the DSP R x instruction is dependent on the mode of the 7-segment display:

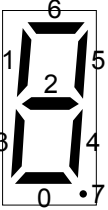
Mode	Content of R x	Effect of DSP R x instruction	
6-digit	- 99,999 to +999,999  outside this range	The value in the register is displayed right-justified. Only integer values in decimal format can be displayed  no display; the error flag is set	
2-digit	0 to 99  outside this range	The value is displayed in the two rightmost digits. The four digits to the left of these are unchanged  No display; the error flag is set	
Free mode	0 to 11111111 binary or 0 to 255 decimal	The segments of the rightmost digit are set according to the following layout:  (Bit 0 = lowest value bit)  Example: R x is binary 01110101; a 3 is displayed with no decimal point	

### 3.20.3 PCD2.F530 7-Segment LED display (PCD2.M120/M150 only)

This module combines the 7-segment display of a PCD2.F510 (please refer to the preceding section) and the two serial ports of a PCD2.F520 (details in section 3).

### 3.20.4 PCD7.D16x Small terminal kits

The PCD1 and PCD2 CPUs can be fitted with a small terminal, mounted in the cover:



3

There are 4 × 16 characters available, and the dialogue can be conveniently created in the HMI Editor. The HMI Editor is an integral part of the PG5 software.

The terminal communicates with the CPU via a communication module, which occupies socket B or B1. The following variants are available:

Kit	Communication module, additional interfaces	Suitable for
PCD7.D162	PCD2.F540 <sup>1)</sup> <b>No additional interfaces</b> ; the terminal occupies Port 2	PCD1.M1xx PCD2.Mxx0
PCD7.D163	PCD2.F550 <sup>1)</sup> <b>One additional RS-485 / RS-422 interface</b> (occupies Port 3 <sup>2)</sup> ), the terminal occupies Port 2	PCD2.M120/M150/M170/M480
PCD7.D164	PCD7.F774 <sup>1)</sup> <b>Profibus DP Slave<sup>3)</sup> and an additional RS-485 / RS-422 interface</b> (occupies Port 3 <sup>2)</sup> ); the terminal occupies Port 2	PCD1.M13x PCD2.M120/M150/M170
PCD7.D165	PCD7.F804 <sup>1)</sup> <b>LON interface<sup>4)</sup> and an additional RS-485 / RS-422 interface</b> (occupies Port 3 <sup>2)</sup> ); the terminal occupies Port 2	PCD1.M13x PCD2.M120/M150/M170

- 1) Only obtainable as part of the PCD7.D16x kit
- 2) The connection is identical to Port 3 on a PCD2.F520; please refer to section 4 for more details
- 3) For Profibus DP, minimum hardware and firmware versions are required; please refer to the Profibus DP manual 26/765
- 4) For LON, minimum hardware and firmware versions are required; please refer to the LON manual 26/767



We recommend ordering the PCD7.D16x kits mounted on the CPUs. Mounting later is possible, but requires:

PCD1: replacing the cover, item-no. 4 104 7338 0

PCD2: removing the red viewing window and drilling 4 mounting holes; the position of the holes can be seen on the inside of the cover

## 3.21 Interrupt inputs

### 3.21.1 Basics

Because of the input filters and the effect of the cycle time, the digital input modules are not suitable for immediate reaction to events or for rapid counting processes. Some CPUs have interrupt inputs for this purpose.

When a positive edge is detected at the interrupt input, an associated XOB is called (e.g. XOB 20). The code in this XOB defines how the unit should react to the event, e.g. by incrementing a counter.



The code in XOBs called from interrupt inputs must be kept as brief as possible to allow enough time between the interrupts to process the rest of the user program.



Many FBoxes are intended for cyclic invocation and so not suitable for use in XOBs, or only in a limited way.

Exception: the FBoxes in the Graotec family (standard library) are well suited

### 3.21.2 PCD1.M120/M130 and PCD1.M125/M135

The two interrupt inputs are located on the motherboard and can be connected via the 6-pole, plug-in terminal block (terminals 20 to 25). Source operation is always used.

When a positive edge is detected at input **INB1**, **XOB 20** is called; a positive edge at input **INB2** causes **XOB 25** to be called. The reaction time up to the XOB 20/25 call is a maximum of 1 ms. The code in this XOB defines how the unit should react to the event, e.g. by incrementing a counter (input frequency max. 1 kHz where pulse/pause each 50%, total of the two frequencies max. 1 kHz). If the relevant XOB is not programmed, the ERROR LED is switched on or XOB 13 is called.

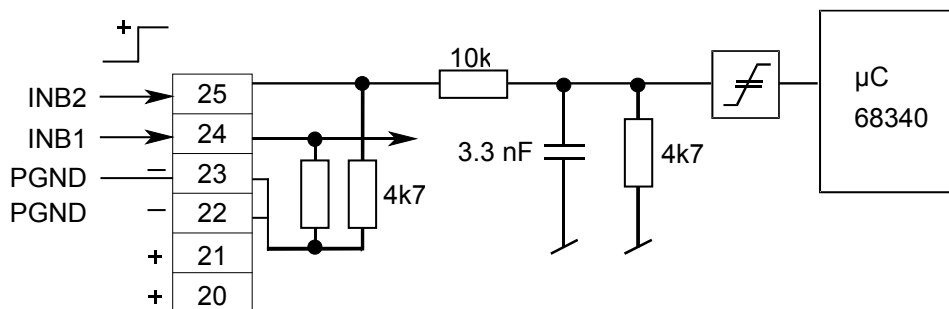

Input signals: (always source operation with PCD1.M12x and PCD1.M13x):

H = 15.. 30 V

L = -30..+5 V or no connected



### 3.21.3 PCD2.M120/M150/M170

The two interrupt inputs are located on the motherboard and can be connected via the 10-pole, plug-in terminal block (terminals 0 to 9). Either source or sink operation may be used.

#### Function in source and sink operation:

When a positive edge is detected at input **INB1**, **XOB 20** is called; a positive edge at input **INB2** causes **XOB 25** to be called. The reaction time up to the XOB 20/25 call is a maximum of 1 ms. The code in these XOBs defines how the unit should react to the event, e.g. by incrementing a counter (input frequency max. 1 kHz where pulse/pause each 50 %, total of the two frequencies max. 1 kHz). If the relevant XOB is not programmed, the ERROR LED is switched on or XOB 13 is called.

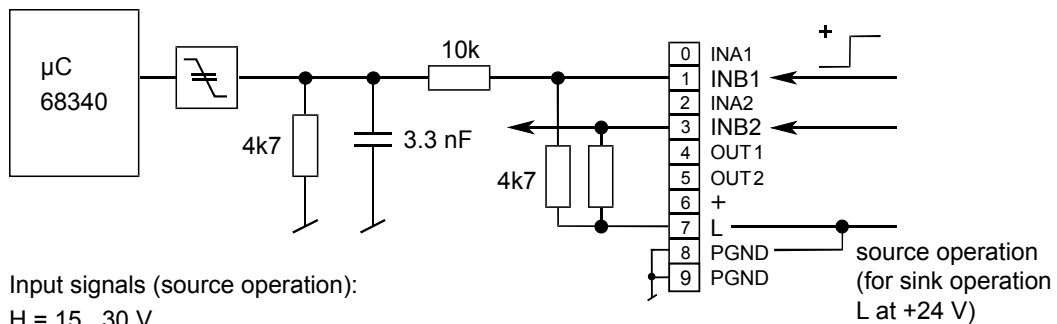

Input signals (source operation):

H = 15.. 30 V

L = -30.. + 5 V or no connected

Input signals (sink operation):

H = 15 .. 30 V or no connected

L = -30.. + 5 V



The INA1, INA2, OUT1, OUT2 and + connections are intended for future enhancements and must not be used.

### 3.21.4 PCD2.M480

The four interrupt inputs are located on the motherboard and can be connected via the 10-pole, plug-in terminal block (terminals 0 to 9). Either source or sink operation may be used.

#### Function in source and sink operation:

Each interrupt input is mapped to an XOB that will be called when there is a positive edge at the input. The code in these XOBs defines how the unit should react to the event, e.g. by incrementing a counter (input frequency max.

1 kHz where pulse/pause each 50 %). The reaction time up to the XOB 20...23 call is a maximum of 1 ms.

If the relevant XOBs are not programmed, the interrupt inputs can be used in the user program like normal inputs from address 8100 upwards.

Interrupt input	XOB called in case of a positive edge	Input where the relevant XOB is not programmed
IN0	XOB 20	I 8100
IN1	XOB 21	I 8101
IN2	XOB 22	I 8102
IN3	XOB 23	I 8103

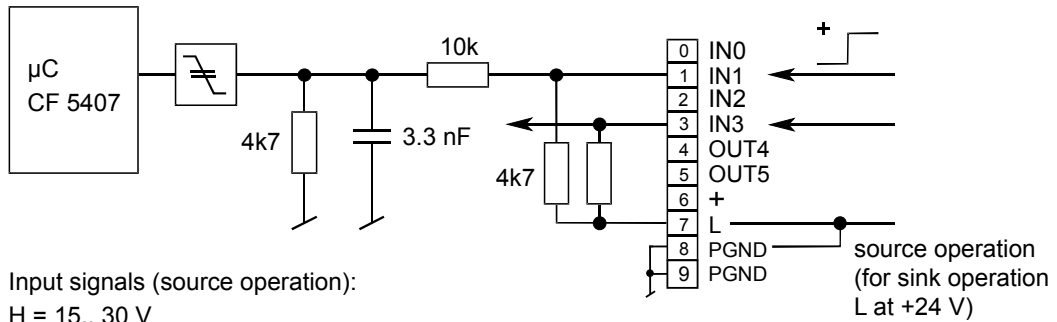

Outputs OUT4 and OUT5 can be used as “normal”, short-circuit-proof transistor outputs with addresses O 8104 and O 8105, and each loaded up to 0.5 A.

Where the OUT4/OUT5 outputs are used, the + connection (terminal 6) must have a +24 V supply.

### 3.22 Run/Stop or Run/Halt switch (PCD2.M170/M480 only)

Traditionally, Saia PCD® controllers could only be reliably set to RUN or STOP mode from the PG3/4/5. With the PCD2.M170 and PCD2.M480 CPUs, it is also possible to influence the operating state with one of the switches accessible on the front.

On the PCD2.M170, the switch is labelled Run/Halt; on the PCD2.M480, it is labelled Run/Stop, in keeping with the practice for xx7 CPUs.

With both controllers, switching to STOP/HALT causes a change from RUN to HALT mode; switching to RUN causes a cold start to be executed.

As delivered from the factory, the Run/Stop or Run/Halt switch is deactivated; it can be activated with a jumper located right next to the switch:

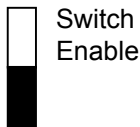
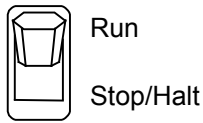

Only move jumpers with the supply switched off!

**3.23 HALT switch on PCD1.M125 and PCD1.M135**

Beside the IC socket for the user memory a switch is on the controllers PCD1.M125 and PCD1.M135. If this switch is pressed during starting the Saia PCD® controller, the controller goes not into the run mode, but remains in the HALT mode.

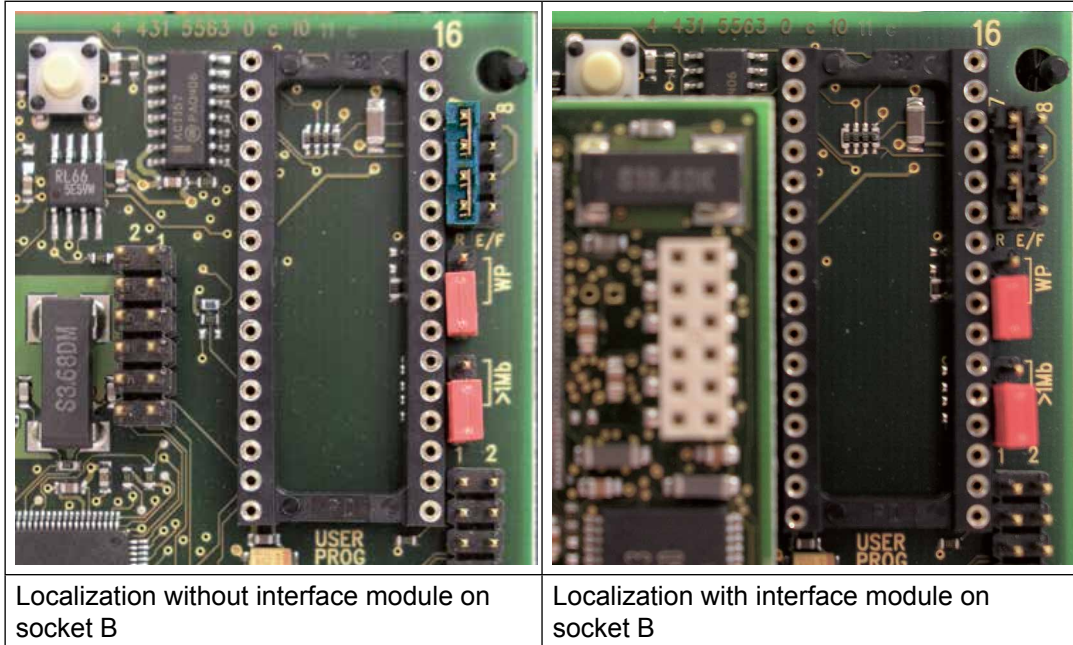

The Saia PCD® controller changes only after a cold start into the Run Mode. I.e. the supply of the control must be switched off/on for it, with not pressed switch.

**3.23.1 HALT switch on PCD1.M125 and PCD1.M135 as input**

The switch described above can be read in as entrance during normal operation. The cover of the Saia PCD® must be removed and the switch must be read in over a SYSRD command for this manipulation. So, this switch is only to use for special functions (start-up, service...).

Instruction :	<b>SYSRD</b>	<b>K 8000</b>	
		<b>R_Switch</b>	; Diagnostic register

Description of the diagnostic register		
bit	state	cause
0 (LSB)	1 (high)	switch not pressed
	0 (low)	switch pressed

**3.24 Storing data in EEPROM**

On the PCD1/PCD2, an EEPROM is used to store configuration data. Part of this is available to the user to store 32-bit values (EEPROM register). These values are not lost even in the case of battery failure or an empty buffer capacitor.

On the PCD1 there are five EEPROM registers (addresses 2000 to 2004); on the PCD2 there are fifty (addresses 2000 to 2049). The EEPROM registers are independent of the "normal" registers with the same addresses.

The values are read with a SYSRD instruction and written with a SYSWR instruction:

Read:

<b>SYSRD</b>	<b>K x or R x</b> <b>R y</b>	; K x is the address of the EEPROM ; register in the range K 2000 to K 2004 ; for PCD1 CPUs, or K 2000 to K 2049 ; for PCD2 CPUs  ; Alternatively, the address of a register ; can also be passed, containing the ; address of the EEPROM register (same ; ranges as for K constants)
		; R y is the target register

Write:

<b>SYSWR</b>	<b>K x or R x</b> <b>R y</b>	; K x is the address of the EEPROM ; register in the range K 2000 to K 2004 ; for PCD1 CPUs, or K 2000 to K 2049 ; for PCD2 CPUs  ; Alternatively, the address of a register ; can also be passed, containing the ; address of the EEPROM register (same ; ranges as for K constants)
		; R y is the source register



When using the instruction SYSWR K 20xx, note the following:

- The EEPROM can be written to a maximum of 100,000 times, so it is not permissible to invoke the instruction in a cyclic manner or at short intervals
- The processing time for the instruction is approx. 20 ms. For this reason, the instruction must not be invoked in XOB 0 (XOB for a power outage) or during time-critical processes

In order to use the EEPROM register, the following minimum firmware versions are required:

CPU type	Minimum firmware version
PCD1.M1x0	001
PCD1.M1x5	001
PCD2.M110/120	004
PCD2.M150	0A0
PCD2.M170	010
PCD2.M480	010

**3.25 Resetting the outputs on STOP or HALT (PCD2 only)**

A jumper can be used to configure whether the outputs should all remain in their current state in a STOP or HALT state, or be reset.

The jumper in question is written to by RO or ROE (Reset Output Enable), and has two positions:

Position	Behaviour
RO/ROE	All outputs are reset in the STOP and HALT states
not RO/ROE	The outputs remain unchanged in the STOP and HALT states (factory setting)

When the user program is downloaded with PG5, there is interaction between the PG5 options and those of the RO jumper:

The outputs are only retained if the jumper is in the “not RO” position **and** the “Do not clear Outputs on download or restart” option shown below is activated. In all other cases, the outputs are reset.

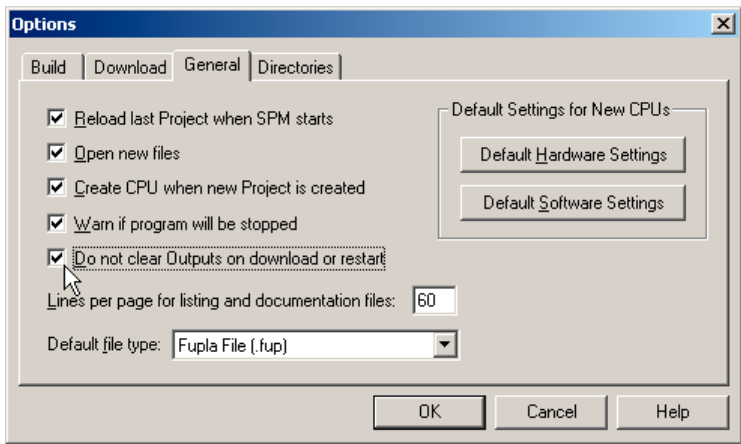

### 3.26 Presence/voltage monitoring for expansion unit (PCD2 only)

With all PCD2s except the PCD2.M110, it is possible to detect the presence of an expansion unit.

In conjunction with PCD3.C200 Modules it is also possible to recognize whether the closest C200 to the CPU is connected to the supply.

A jumper can be used to configure whether the monitoring is activated.

Position	Behaviour
XOB 1 ENABLE	Monitoring is switched on. In the following cases, XOB 1 is called: <ul style="list-style-type: none"> <li>• no expansion unit is connected at start-up</li> <li>• at start-up, one of the PCD3.C200 units in the system is not on</li> <li>• during operation, the connection to the expansion unit(s) is lost</li> <li>• during operation, the supply to one of the PCD3.C200 units in the system fails</li> </ul>
not XOB 1 ENABLE	Monitoring is switched off (factory setting)

The code in XOB 1 defines how the unit should react to the event. If it is called from the monitoring function, but has not been programmed, an entry will be written to history and the Error LED will be set.

## 4 Saia PCD® Classic communication interfaces

### 4.1 General informations

#### 4.1.1 Outphased interface modules

Article	Active	Not recommended for new projects	Outphased (no longer produced)
PCD2.F510			x
PCD2.F520	x		
PCD2.F522	x		
PCD2.F530	x		
PCD2.T500	x		
PCD2.T813			x
PCD2.T814	x		
PCD2.T850			x
PCD2.T851	x		
...			
PCD7.D163	x		
PCD7.D164	x		
PCD7.D165	x		
...			
PCD7.F110	x		
PCD7.F120		x	
PCD7.F121	x		
PCD7.F130	x		
PCD7.F150	x		
PCD7.F180	x		
...			
PCD7.F650			x
PCD7.F651			x
PCD7.F655	x		
PCD7.F700			x
PCD7.F750	x		
PCD7.F770	x		
PCD7.F772	x		
PCD7.F800	x		
PCD7.F802	x		



### 4.1.2 SBCS-Net

SBCS-Net, the networking concept from Saia Burgess Controls, is based on the RS-485, Profibus and Ethernet open standards. Ethernet covers layers 1 and 2 of the ISO layer model. Based on layer 2, a variety of different protocols and applications can be run in parallel on the same network.



#### Using the SBC S-Bus

**The proprietary SBC S-Bus has been designed essentially for communication with the engineering and debugging tools, and for connecting the management level/process control systems.**

**It is neither suitable nor approved for the connection of field devices from diverse manufacturers. An open, vendor-neutral fieldbus will be more effective in achieving this end.**

4



#### For PCD2.M480 only:

Layer 2 (Field Data Link-FDL) from Profibus also allows parallel running of different application protocols such as DP, FMS and others. The use of this facility allows Profi S-Net to be used to create a "Private Control Network (PCN)". This makes all SBC units into active network components.

Profibus Layer 2 (FDL) is integrated into the operating system of the PCD2.M480 CPUs, giving these units a Profi S-Net connection with transmission speeds up to 1.5 Mbps.

These units support Profibus DP and S-Net on the same port. In this way, Profibus can be used to construct networks cheaply and flexibly (detailed notes can be found in TI 26/381).



#### Transmission rates (Baud rates) of the PCD2.M480:

The controllers of the type PCD2.M480 have a new SBC NT operating system. With the new operating system higher transmission rates (SBC S-Bus up to 115 kBit/s) can be achieved, however low baud rates (300 and 600 Baud/sec.) are no more supported.

4.2 Summary of PCD1/PCD2 onboard interfaces

Base unit with onboard interfaces	Summary without plug-in communication modules					
	Port#	RS-485	(PGU) RS-232	(PGU) RS-232/RS-485	USB	Profi S-Net
<b>PCD1.M110</b> 	0	-	■	-	-	-
	1	■	-	-	-	-
<b>PCD1.M120/M125</b> 	0	-	■	-	-	-
<b>PCD1.M130/M135</b> 	0	-	■	-	-	-
<b>PCD2.M110</b> 	0	-	-	■	-	-
<b>PCD2.M120</b> 	0	-	-	■	-	-
<b>PCD2.M150</b> 	0	-	-	■	-	-
<b>PCD2.M170</b> 	0	-	-	■	-	-
<b>PCD2.M480</b> 	0	-	■	-	-	-
	6	■	-	-	-	-
	USB	-	-	-	■	-
	Profi S-Net	-	-	-	-	■

**4.3 Summary of PCD1 plug-in interface modules**

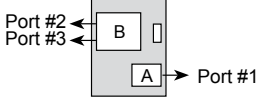
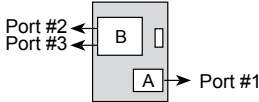
Base unit with sockets for plug-in communication modules	Summary of plug-in communication modules														
	Socket	Serial								Ethernet	Profibus			LON	
		PCD7.F110	PCD7.F120 <sup>1)</sup>	PCD7.F121 <sup>1)</sup>	PCD7.F130	PCD7.F150	PCD7.F180	PCD2.F520	PCD2.F522 <sup>1)</sup>		PCD7.F65x	PCD7.F700	PCD7.F750	PCD7.F770	PCD7.F772
PCD1.M110 	A	-	-	-	-	-	-	-	-	-	-	-	-	-	-
	B	-	-	-	-	-	-	-	-	-	-	-	-	-	-
PCD1.M120/M125 	A	■	■	■	■	■	■	-	-	-	-	-	-	-	-
	B	-	-	-	-	-	-	-	-	-	■	■	-	■	-
PCD1.M130/M135 	A	■	■	■	■	■	■	-	-	-	-	-	-	-	-
	B	-	-	-	-	-	-	-	■ <sup>2)</sup>	-	■	■	-	■	-

1) Suitable for modem connection, as 6 control lines provided.

2) With special housing cover 4 104 7409 0 or as configured system with type-no. PCD1.M135F655

4.4 Summary of PCD2 plug-in interface modules

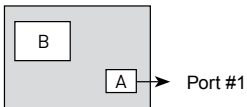
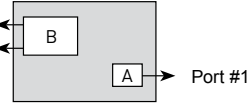
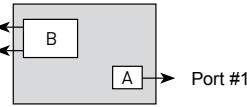
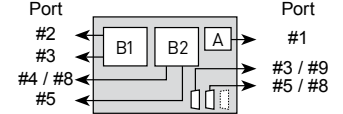
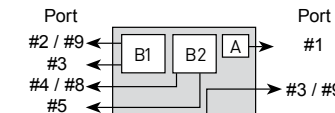
Base unit with sockets for plug-in communication modules	Summary of plug-in communication modules														
	Socket	Serial							Ethernet	Profibus			LON		
		PCD7.F110	PCD7.F120 <sup>1)</sup>	PCD7.F121 <sup>1)</sup>	PCD7.F130	PCD7.F150	PCD7.F180	PCD2.F520		PCD2.F522 <sup>1)</sup>	PCD7.F65x	PCD7.F700	PCD7.F750	PCD7.F770	PCD7.F772
<b>PCD2.M110</b> 	A	■	■	■	■	■	■	-	-	-	-	-	-	-	-
	B <sup>5)</sup>	-	-	-	-	-	-	-	-	-	-	-	-	-	-
<b>PCD2.M120</b> 	A	■	■	■	■	■	-	-	-	-	-	-	-	-	-
	B	-	-	-	-	-	■	■	-	■	■	■	■	■	■
<b>PCD2.M150</b> 	A	■	■	■	■	■	-	-	-	-	-	-	-	-	-
	B	-	-	-	-	-	■	■	■ <sup>2)</sup>	■	■	■	■	■	■
<b>PCD2.M170</b> 	A	■	■	■	■	■	-	-	-	-	-	-	-	-	-
	B1	-	-	-	-	-	■	■	-	■	■ <sup>3)</sup>	■ <sup>3)</sup>	■ <sup>3)</sup>	■ <sup>3)</sup>	■ <sup>3)</sup>
	B2	-	-	-	-	-	■	■	■	-	■ <sup>3)</sup>	■ <sup>3)</sup>	■ <sup>3)</sup>	■ <sup>3)</sup>	■ <sup>3)</sup>
<b>PCD2.M480</b> 	A	■	■	■	■	■	-	-	-	-	-	-	-	-	-
	B1	-	-	-	-	-	■	■	■	-	■	-	-	-	-
	B2	-	-	-	-	-	■	■	■	-	■ <sup>4)</sup>	-	-	-	-

1) Suitable for modem connection, as 6 control lines provided

2) With special housing cover 4'104'7410'0 or as configured system with type-no. PCD2.M150F655

3) The following combinations are not possible: 2 x Profibus DP Slave / 2 x LONWORKS®

4) PCD7.F750 on PCD2.M480 socket B2 not recommended

**4.5 Onboard interfaces**

**4.5.1 PGU connection (PORT#0, PCD1 and PCD2) (RS-232) for connecting programming devices**

The PGU interface (Port#0) is connected to a 9-pole D-Sub connector (female). The interface is used to connect the programming device when the unit is commissioned.

The interface is of type RS-232c.

The pin configuration and associated signals are:



Pin	Designation	Meaning	
1	DCD	Data Carrier Detected	The equipment signals to the computer that it recognizes data on the line
2	RXD	Receive Data	Line for the receiving of data
3	TXD	Transmit Data	Line for outgoing (sent) data
4	n.c.	Not Connected	Not used
5	SGN	Signal Ground	Signal mass. Signal voltages are measured against this line
6	DSR	PGU Connected	Recognition PGU. Attached equipment signals to the computer that it is operational, if logical unity on this line lies close
7	RTS	Request To Send	Transmitters switch on. „send request“ (if this line on logically unity stands, would like to send the equipment data
8	CTS	Clear To Send	Ready-to-transmit-state. If this line stands on logically “high”, the equipment can receive data
9	+5 V	Supply P100	Supply for the programming unit P100

The PGU protocol is provided for operation with a programming device. The use of the PCD8.P800 service unit is supported from firmware version \$301 for all PCD1/PCD2 controllers.

**PCD8.K111 connecting cable**

(P8 and S-Bus protocol, suitable for all PCD1/PCD2 units)

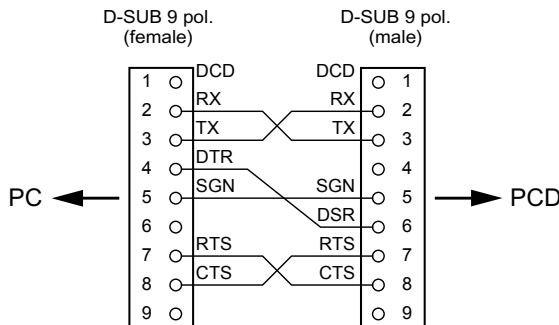

**PCD8.K110 connection cable (obsolete)**

(P8 protocol, suitable for PCD1.M110/120 and PCD2.M110/120 only)

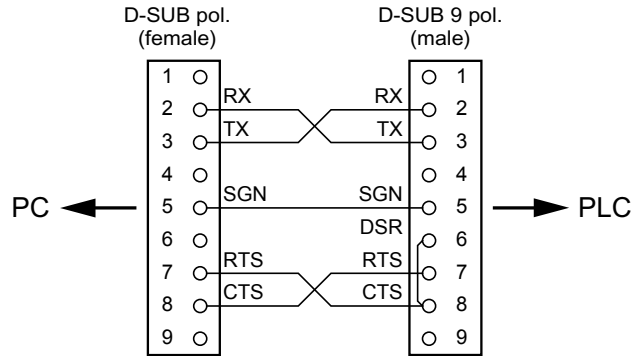

**4.5.2 PGU connection (PORT#0, PCD1 and PCD2) (RS-232) as communication interface**

When commissioning/programming are complete, the port can be used for other purposes.

**Option 1:** Configuration with desired protocol (S-Bus PGU configuration)

**Option 2:** Assignment (SASI) in the user program (the port must not be configured as an S-Bus PGU port)

- If another programming device is connected during operation instead of the peripheral device, the unit will switch over automatically to PGU mode (pin 6 logical "1" (DSR); in PGU mode: DSR PING = "1").
- Before using the port to connect another peripheral device, Port#0 must be reconfigured by means of an SASI instruction.

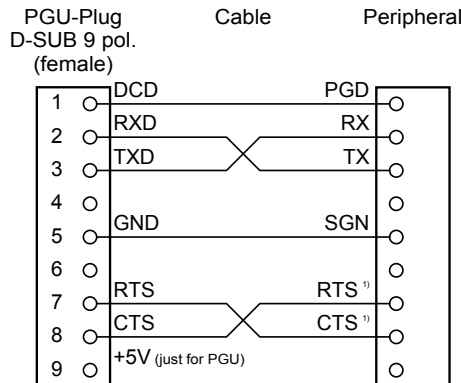

1) When communicating with terminals, check whether some connections are provided with bridges or need to be set to "H" or "L" with the "SOCL" instruction. It is generally recommended to use a handshake (RTS/CTS)

**4.5.3 PGU connection (PORT #0, only on PCD2.M1x0) (RS-485) as communication interface**

If Port#0 is not used via the PGU connection (with the programming device or as an RS-232 interface), it can be used via terminals 28 and 29 for an S-Bus or MC4 connection.

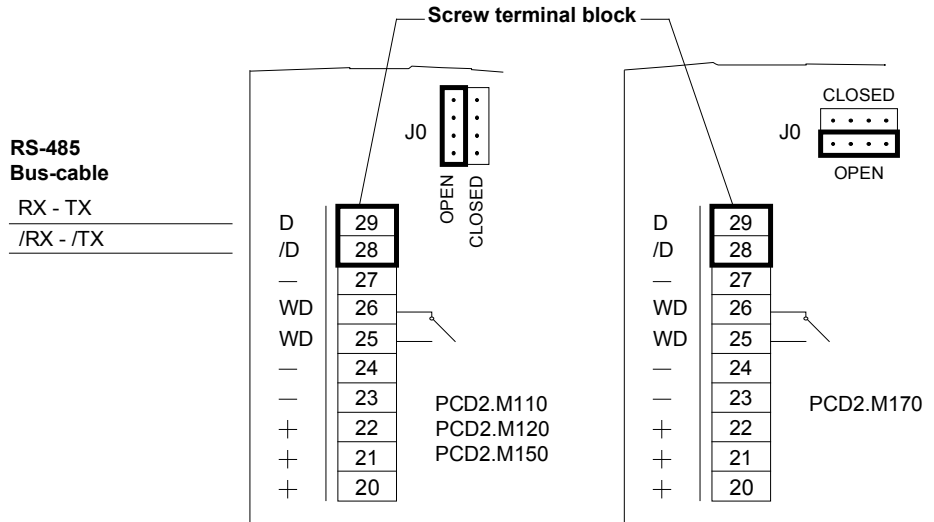

4

**Choice of line termination resistors**

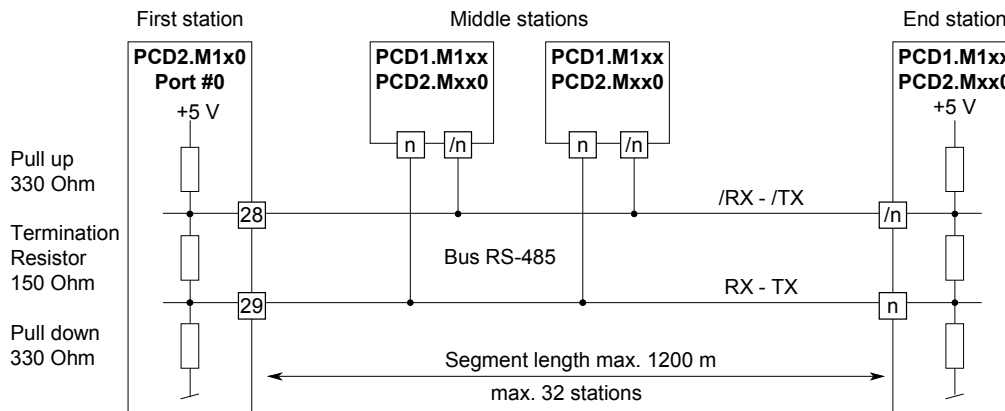

At the first and last stations, jumper J0 must be set to the “CLOSED” position.  
At all other stations, jumper J0 must be set to “OPEN” (factory setting).

**4.5.4 RS-485 communication interface PORT #1, only on PCD1.M110**

On the PCD1.M110, on Port#1, is a built-in RS-485 interface.

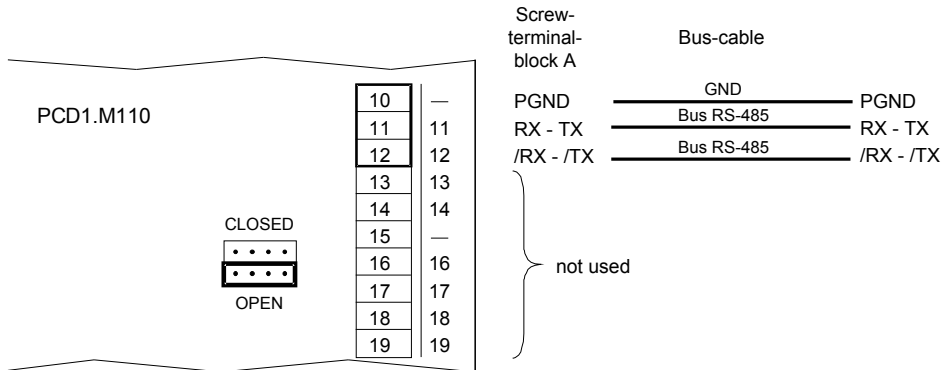

**Choice of the termination resistors**

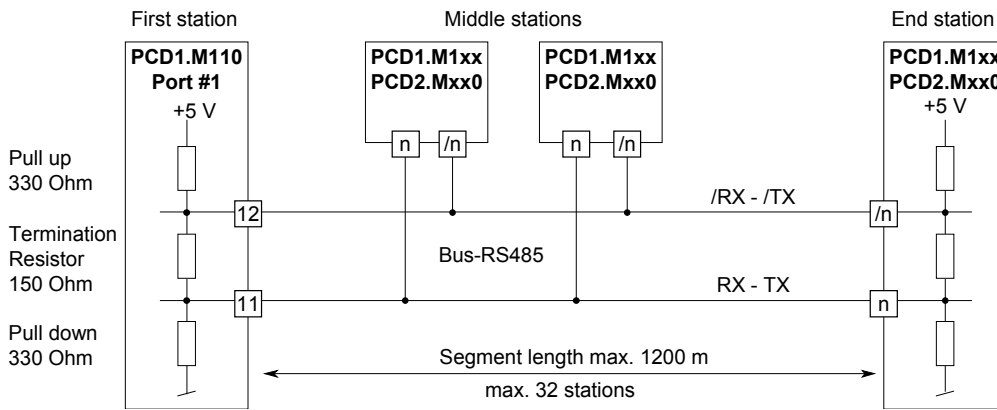

At the first and last stations, the jumper must be set to the “CLOSED” position.  
 At all other stations, the jumper must be set to “OPEN” (factory setting).



**4.5.5 RS-485 communication interface PORT #6, only on PCD2.M480**

On the PCD2.M480, on Port#6, is a built-in RS-485 interface.

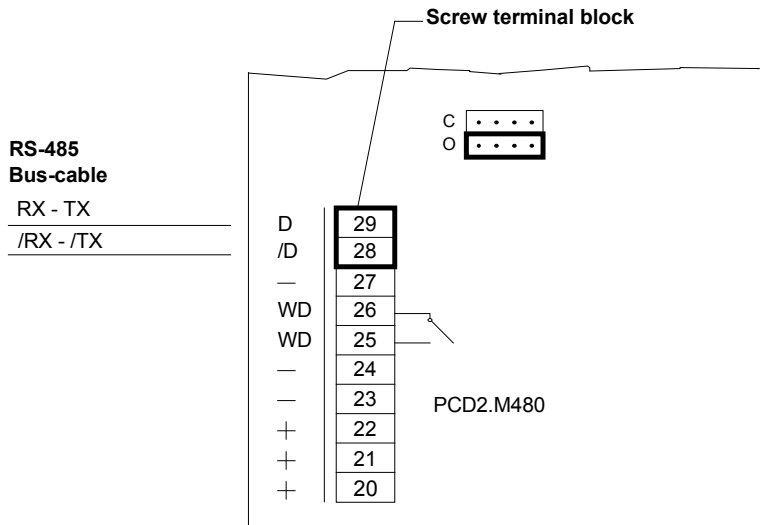

4

**Choice of the termination resistors**

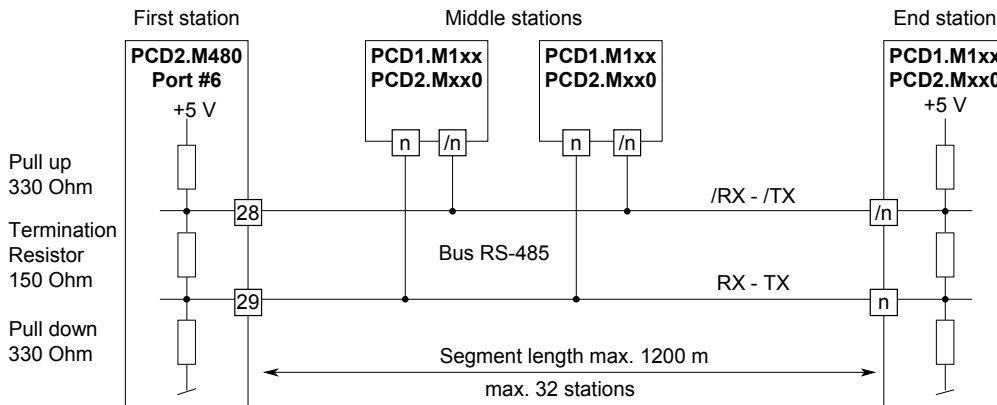

At the first and last stations, the jumper must be set to the “C” (closed) position.  
 At all other stations, the jumper must be set to “O” (open) position (factory setting).

#### 4.5.6 USB interface as PGU interface. on PCD2.M480

The USB interface can be used exclusively as PGU interface. Thus the PGU plug becomes free for other communication connections (RS-232).

In order to use the USB interface on the PCD2.M480, PG5 version 1.3.100 or later must be installed.

When the PCD2.M480 is first connected to a PC via the USB interface, the PC operating system automatically installs the appropriate USB driver.

To establish a connection with a Saia PCD® via USB, the following settings must be entered in the online settings for the PG5 project:

4

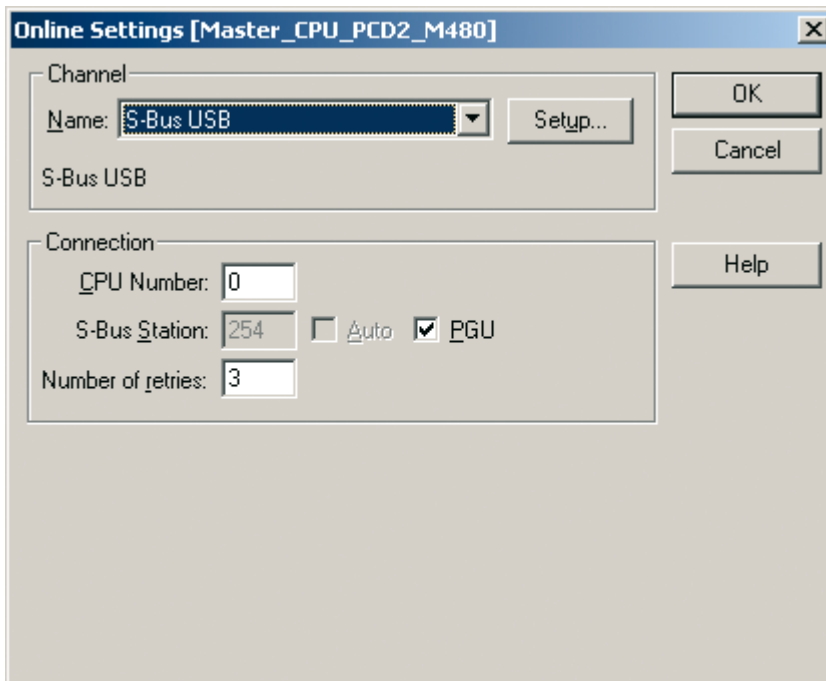

Activating the PGU option ensures that the PCD2.M480 connected directly to the PC can be reached, regardless of the S-Bus address that has been configured.

**4.5.7 Profi S-Net on PCD2.M480**

The PCD2.M480 is equipped with a Profi S-Net interface as standard. This can be used both for programming and for communication with other CPUs (that support Profi S-Bus) and/or SBC RIOs.

Technical details:

Transmission rates up to 1.5 MBit/s

Number of stations up to 124 stations in segments of 32 stations each

Protocols Profi S-Bus, Profi S-IO, DP Slave, HTTP in preparation  
(multi-protocol operation on the same interface)

Connection diagram

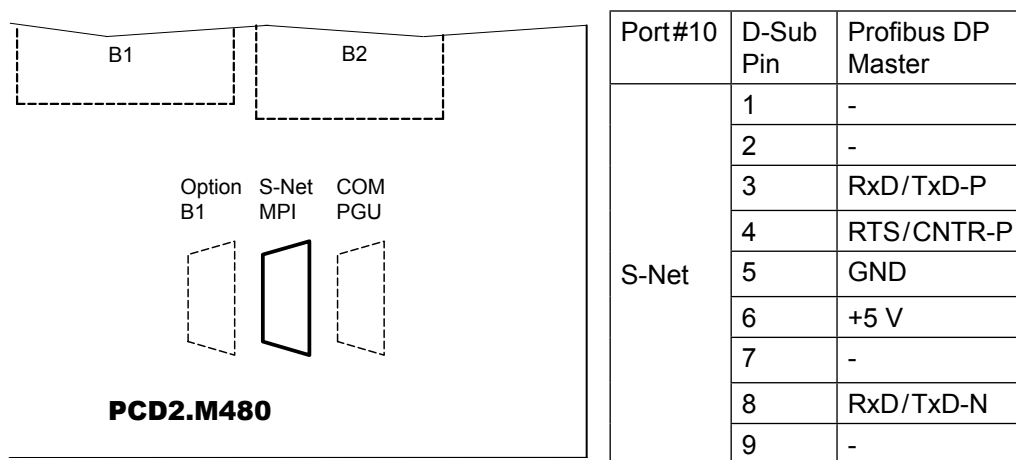

For details of the configuration and programming of Profi S-Net functions, please consult the specialised manuals.

**4.6 Plug-in interfaces modules: Socket A**

**4.6.1 RS-485/422 with PCD7.F110, Port#1 (with PCD1.M110 hard-wired)**

**Connection for RS-485**

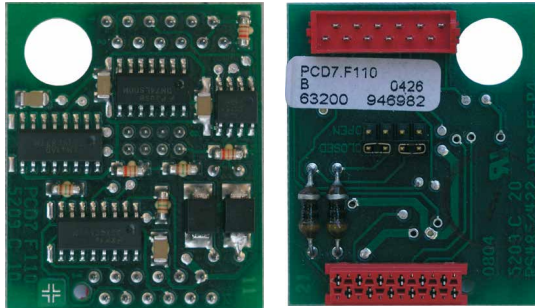

**PCD7.F110:**  
RS-422 with RTS/CTS or RS-485 electrical-ly connected, with line termination resistors capable of activation, for socket A

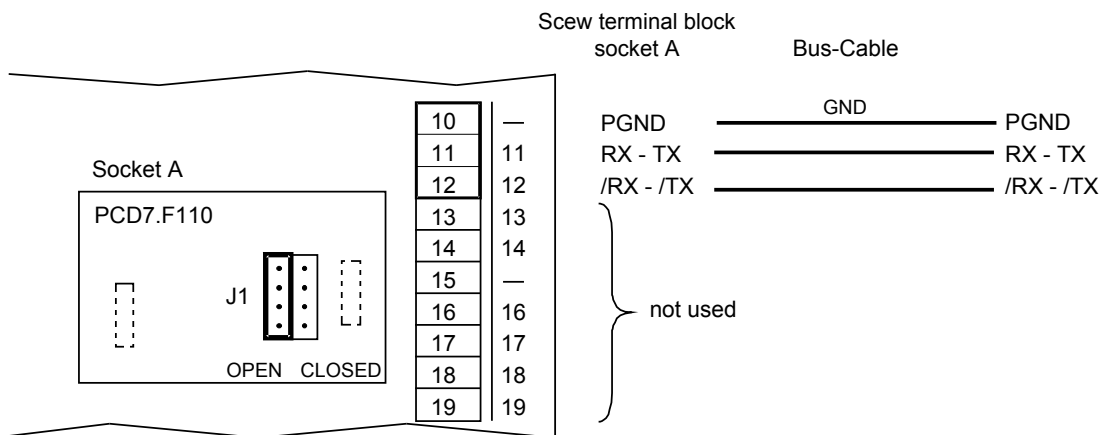

**Choice of line termination resistors**

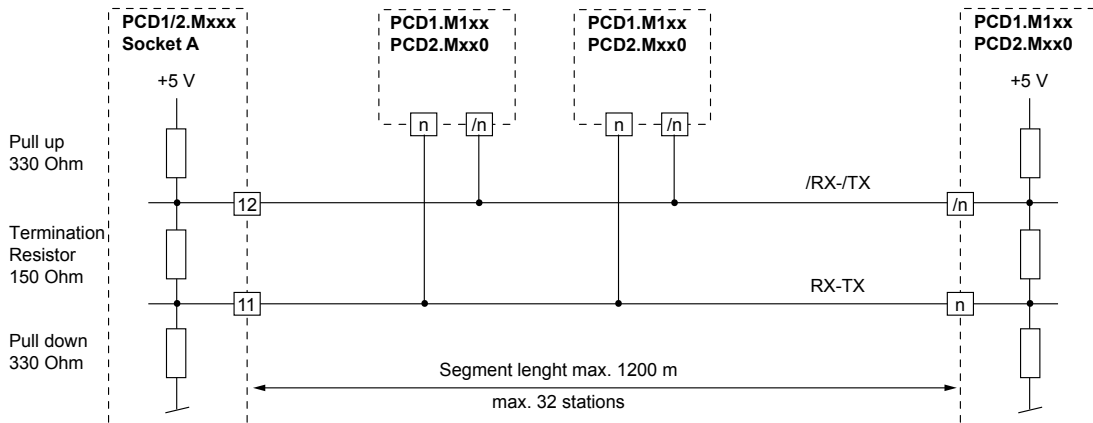

Not all manufacturers use the same connection configuration, so the data lines sometimes need to be crossed.



At the first and last stations, jumper J1 must be set to the “CLOSED” position. At all other stations, jumper J1 must be set to “OPEN” (factory setting). The jumper is on the connection side of the module.



For details, see manual 26/740 :  
“Installation components for RS-485 networks”

Connection for RS-422

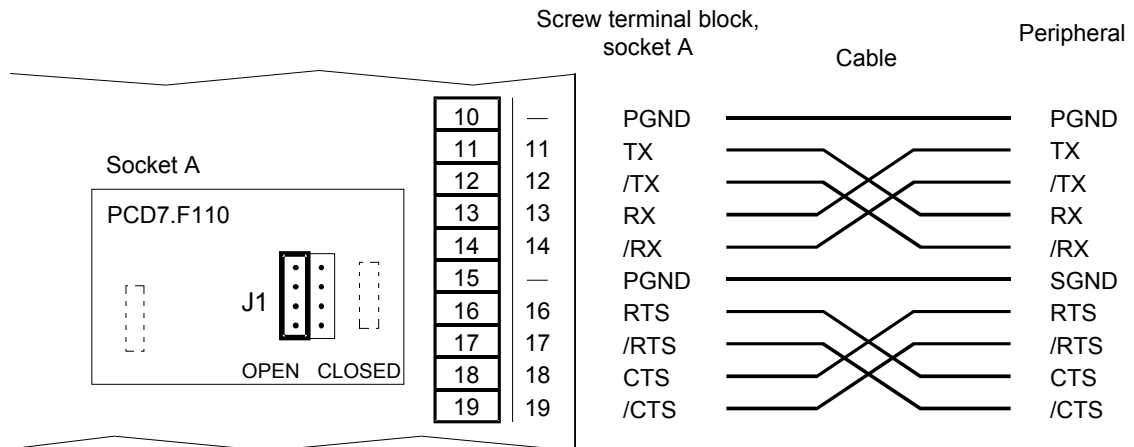

4



For RS-422, each pair of receive lines is terminated with a 150 Ω line termination resistor. Jumper J1 must be left in the “OPEN” position (factory setting). The jumper is on the connection side of the module.

**4.6.2 RS-232 with PCD7.F120 (suitable for modem), Port #1 (without PCD1.M110)**

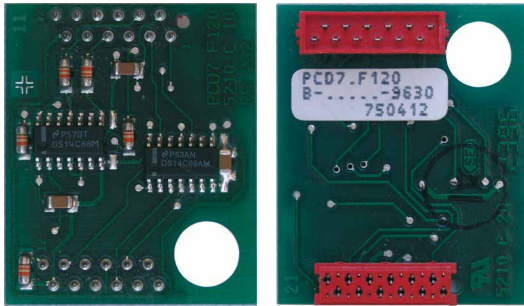

**PCD7.F120:**  
RS-232 with RTS/CTS, DTR/DSR, DCD, suitable for modem connection, for socket A

4

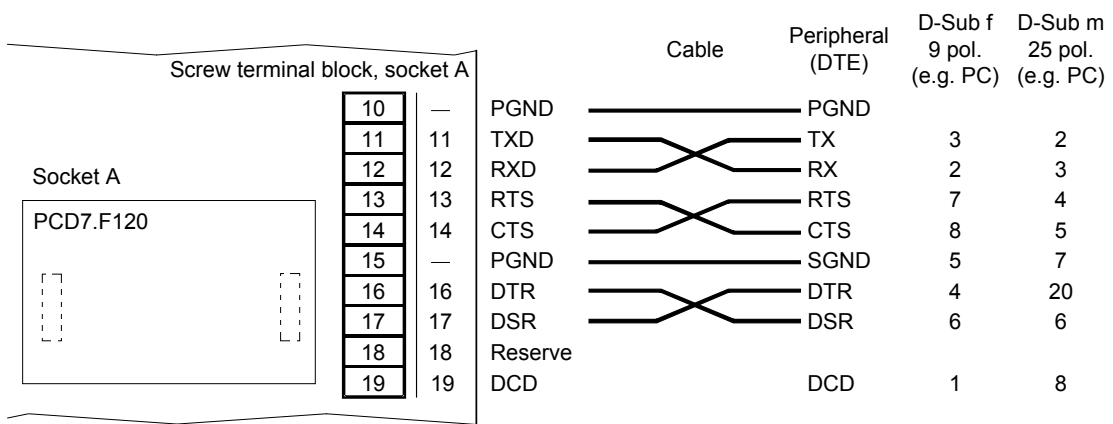

**RS-232 interface, Port #1 for external modem (DCE), socket A**

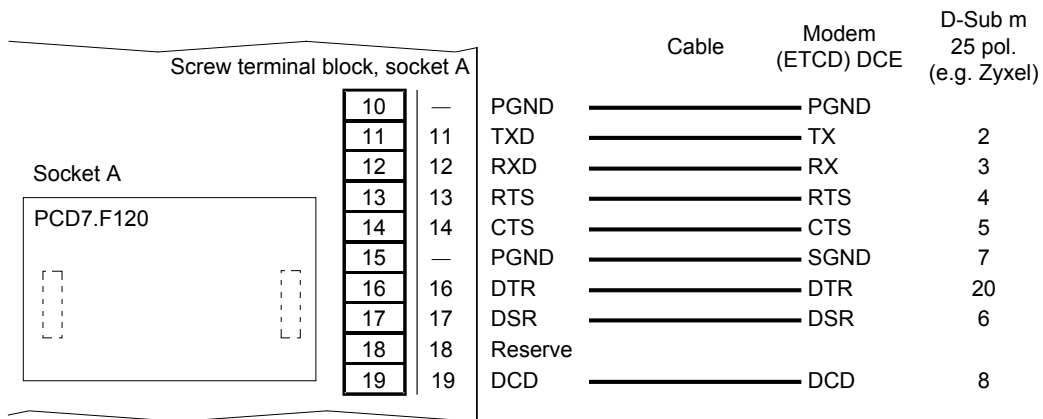

**4.6.3 RS-232 with PCD7.F121, Port#1 (without PCD1.M110)**

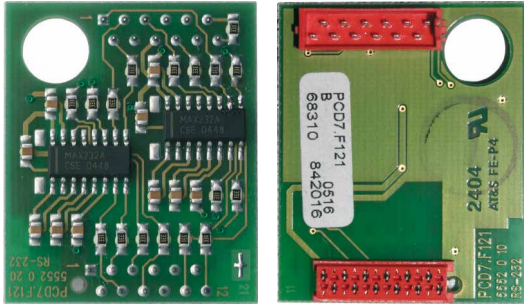

**PCD7.F121:**  
 RS-232 with RTS/CTS, DTR/DSR, DCD,  
 suitable for modem connection, for Socket A.  
 This module can be used up to 115200 Baud

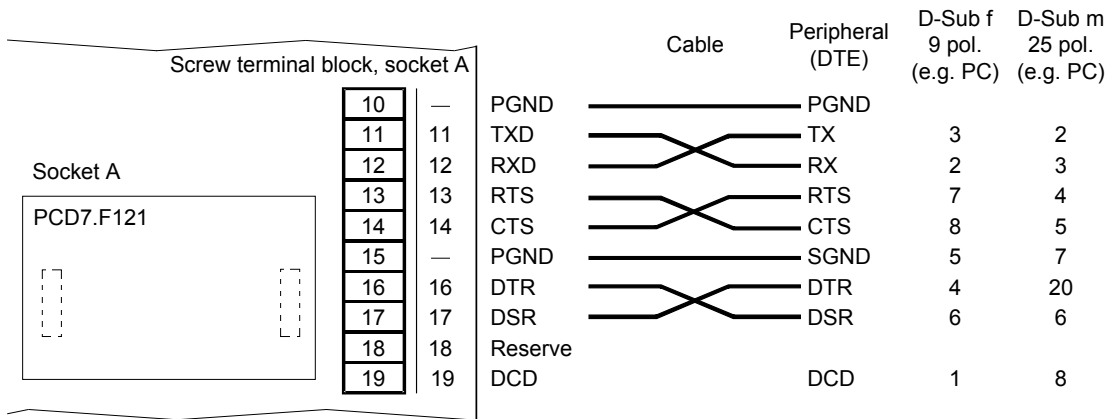

**RS-232 interface, Port#1 for external modem (DCE), socket A**

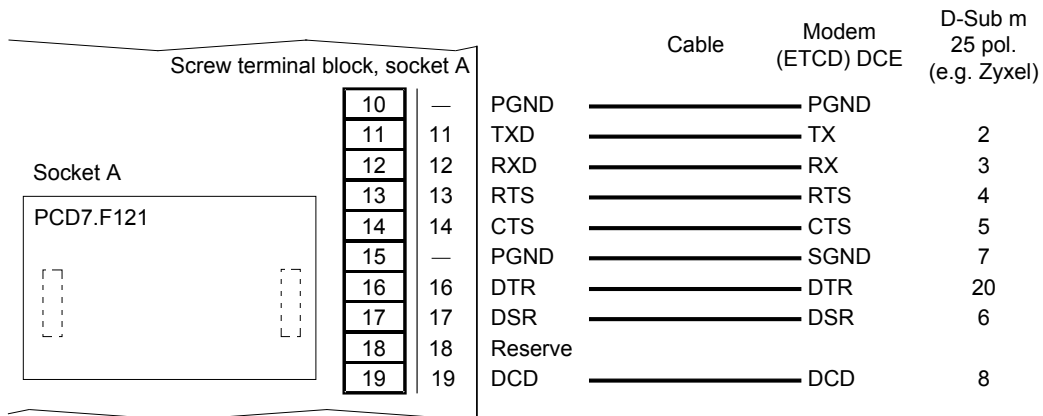

**4.6.4 Current loop with PCD7.F130, Port #1 (without PCD1.M110)**

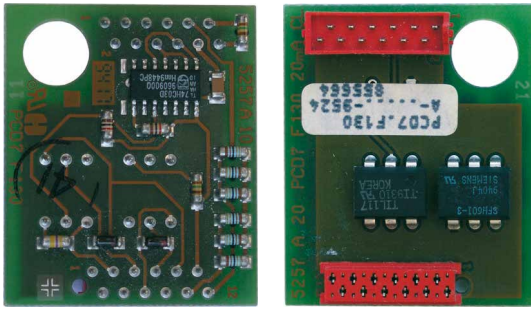

PCD7.F130:  
TTY/current loop 20 mA (active or passive),  
for socket A

**Connections**

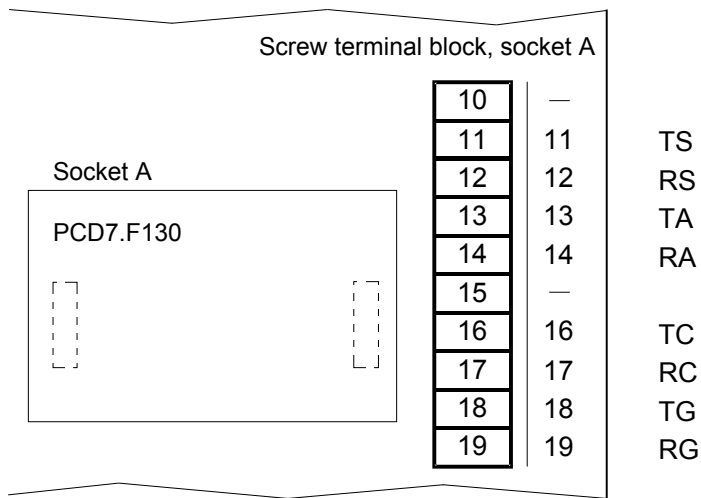

**Saia PCD® active**

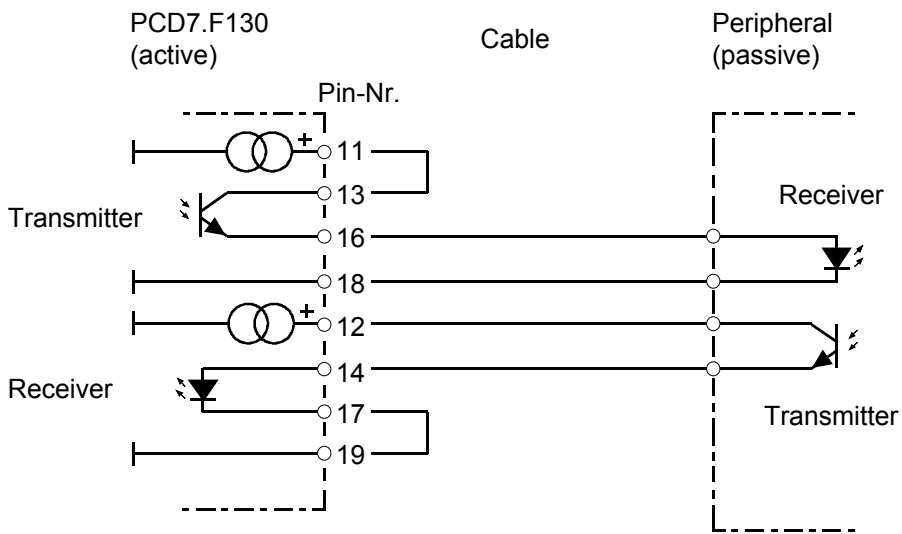



**Saia PCD® passive**

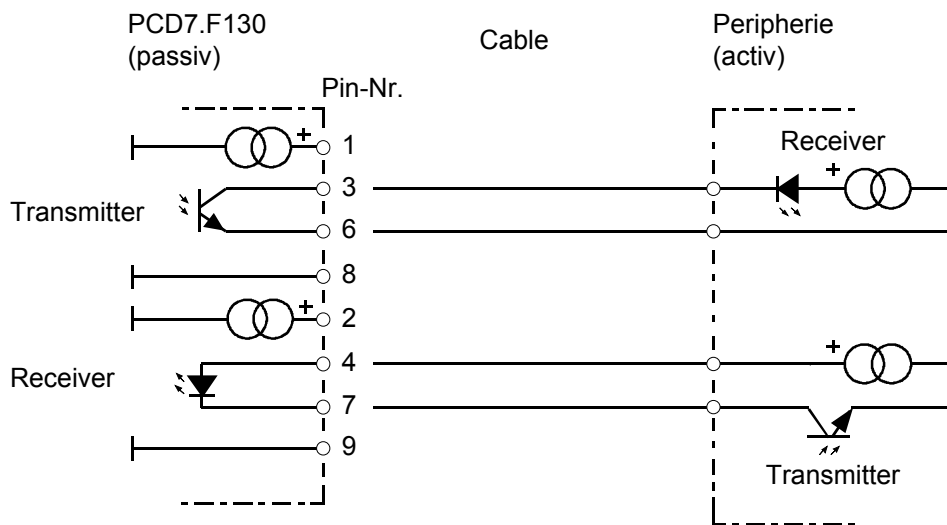

4

**Saia PCD® and peripheral transmitters active**

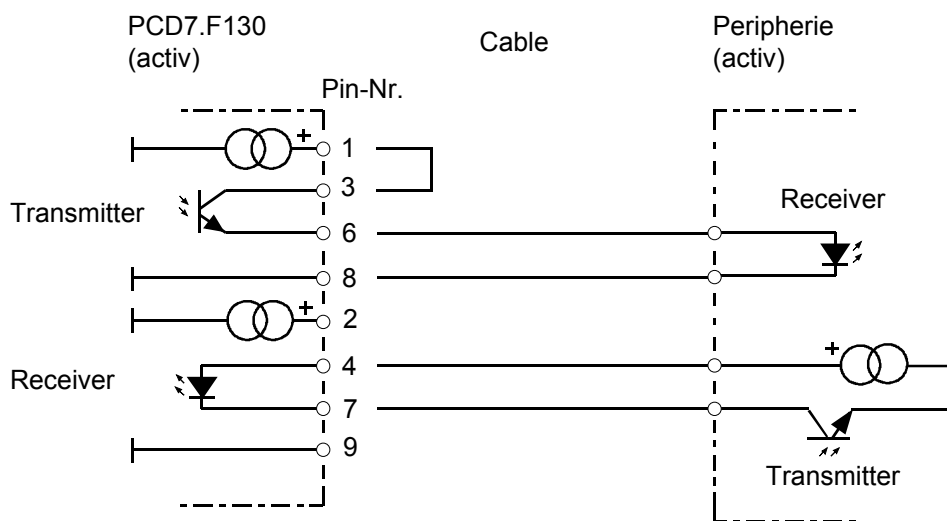

**4.6.5 RS-485 with PCD7.F150, Port#1 (without PCD1.M110)**

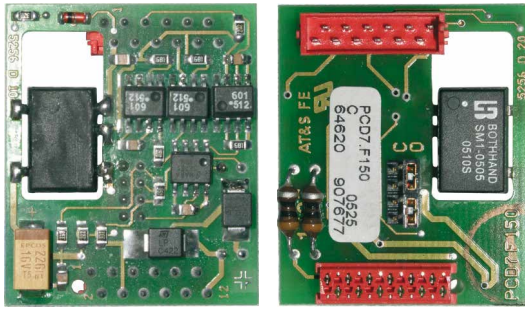

**PCD7.F150:**  
RS-485 electrically isolated, with line termination resistors capable of activation, for socket A

The electrical isolation is achieved with 3 optocouplers and a DC/DC transducer. The data signals are protected against surges by a suppressor diode (10 V). The line termination resistors can be connected/disconnected with a jumper.

4

**Connections**

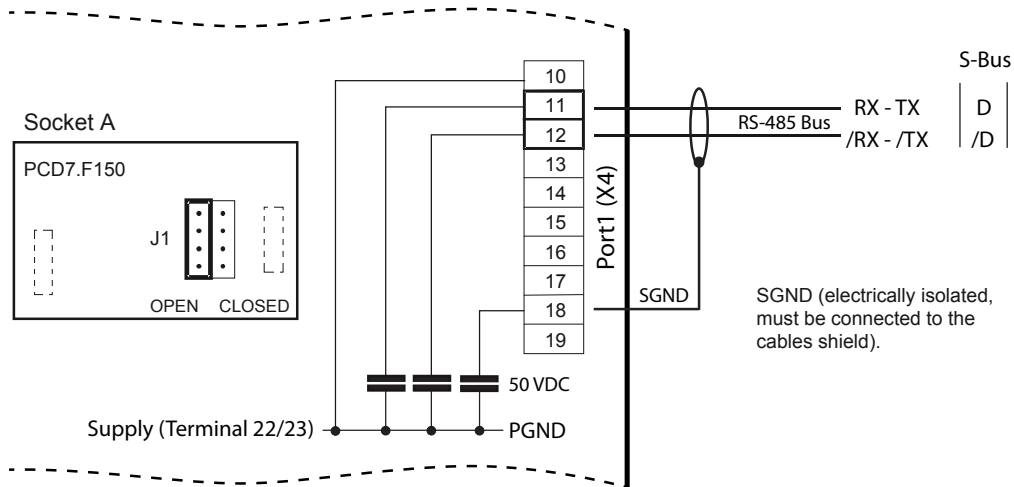

**Block diagram:**

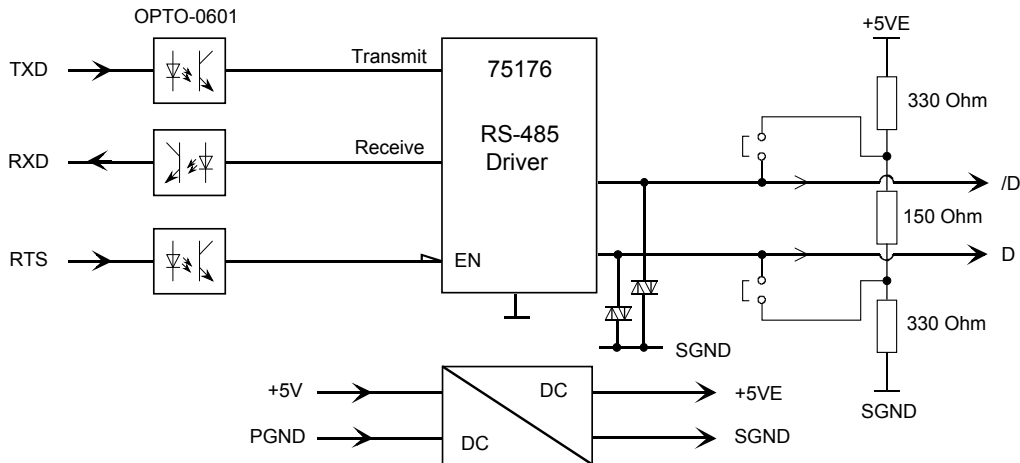

Not all manufacturers use the same connection configuration, so the data lines may need to be crossed.



The potential difference between PGND and the data lines Rx-Tx, Rx-/Tx (and SGND) is limited to 50 V by a suppressor capacitor.



For installation details, see manual 26/740 :  
"Installation components for RS-485 networks".

**4.6.6 MP-Bus with PCD7.F180, Port#1 (without PCD1.M110)**

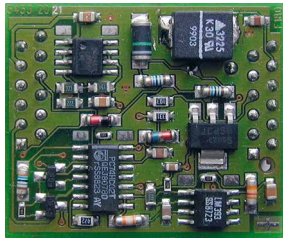

PCD7.F180:

Connecting module for MP-Bus, for socket A

The user has a facility to connect an MP-Bus line with 8 drives and sensors.

**Connections**

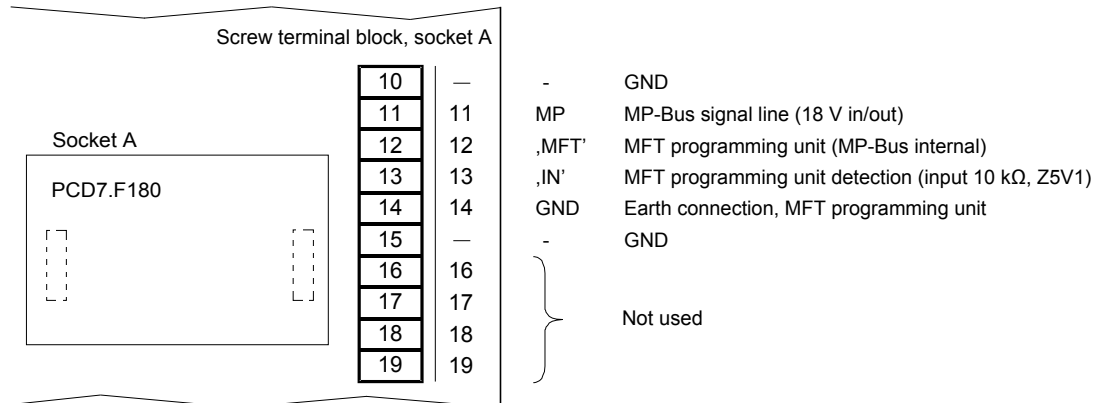

There are the following parameterization devices of BELIMO®:

- Manual Control Unit    MFT-H    With its own power supply/batteries
- PC-Tool                    MFT-P    With the adapter ZIP-RS-232

### Supply option

Common supply for control and drive

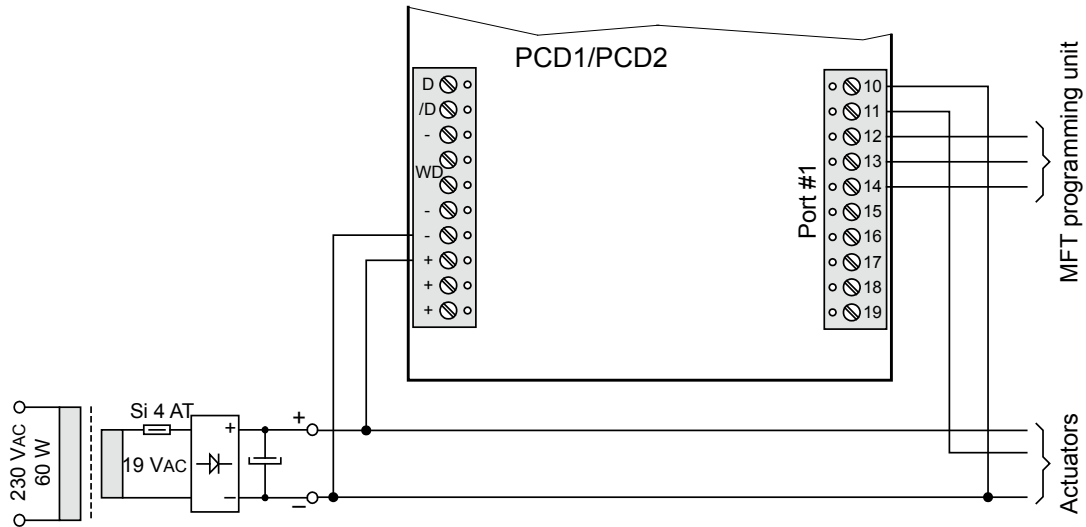

4



When using the PCD7.F180 connection module, the supply voltage to the PC control unit must be at least 24 VDC,  $\pm 5\%$  (not the default tolerance of  $\pm 20\%$ ).



With a separate DC or AC supply to the drives, it is especially important to ensure that the Saia PCD<sup>®</sup> control unit is connected to the earth (Minus pole) of the drive supply. The earth serves as a common base for communication.



For details, see Technical Information P+P26/342 “MP-Bus interface for BELIMO actuating drives”

**4.6.7 Modem communication**

**Modem module for I/O module socket**

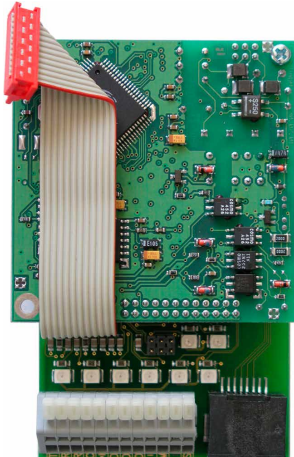

PCD2.T814:  
33.6 kbps analogue modem  
(RS-232 and TTL interface)

PCD2.T851:  
ISDN-TA digital modem  
(RS-232 and TTL interface)

Recommended sockets for connection with ribbon cable:

- PCD1.M130 - socket 2
- PCD2.M120 - socket 4
- PCD2.M130 - socket 4
- PCD2.M150 - socket 4
- PCD2.M170 - socket 1
- PCD2.M480 - socket 1

4



If a different socket is chosen for the internal modem, it can no longer be connected via the ribbon cable. The modem may be connected by a spring clip to the PCD7.F120 (Port 1) or PCD2.F522 (Port 2) interface modules.

External modems can also be connected to the PCD7.F120 or PCD2.F522 modules.



For mechanical reasons PCD2.T8xx modems cannot be inserted at the colored marked socket locations:

PCD1.Mxxx /  
PCD2.C150

#0	#1
#3	#2

PCD2.Mxxx /  
PCD2.C100

#0	#1	#2	#3
#7	#6	#5	#4

 Not permitted socket location

Two modem modules cannot be mounted side-by-side.



For installation details, see manual 26/771  
“PCD2.T8xx modem module”

**4.7 Serial interfaces: socket B(1) or B2**

**4.7.1 RS-485 with PCD2.F520 (PCD2 only)**

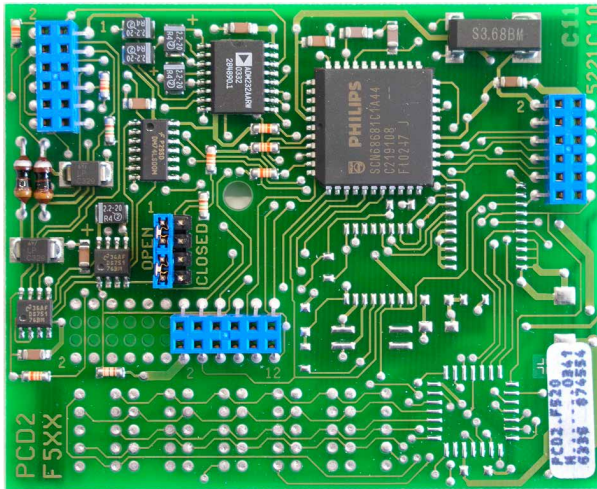

PCD2.F520:  
 1 × RS-232 with RTS/CTS and  
 1 × RS-485 electrically connected  
 or  
 1 × RS-232 with RTS/CTS and  
 1 × RS-422 without RTS/CTS  
 for socket B(1) or B2

**RS-485: socket B(1), Port#3**

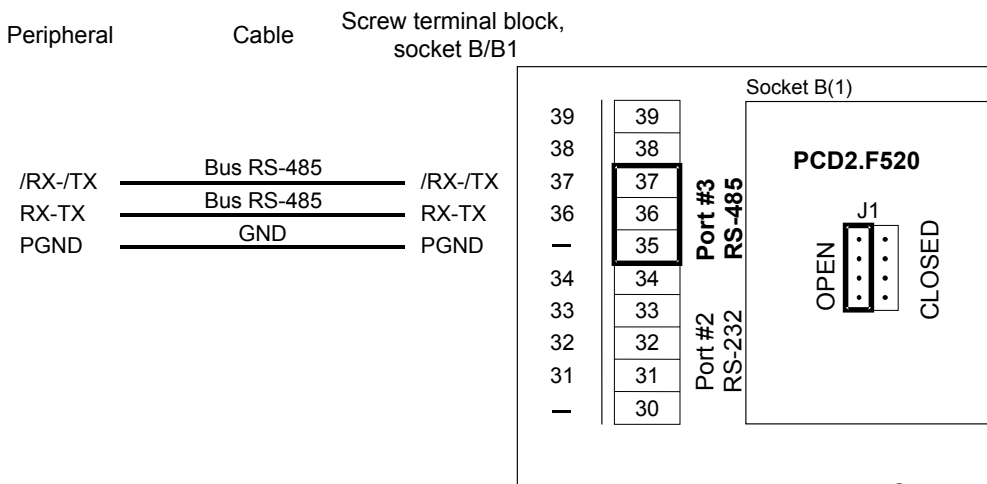

**RS-485: socket B2, Port#5 (M170/M480 only)**

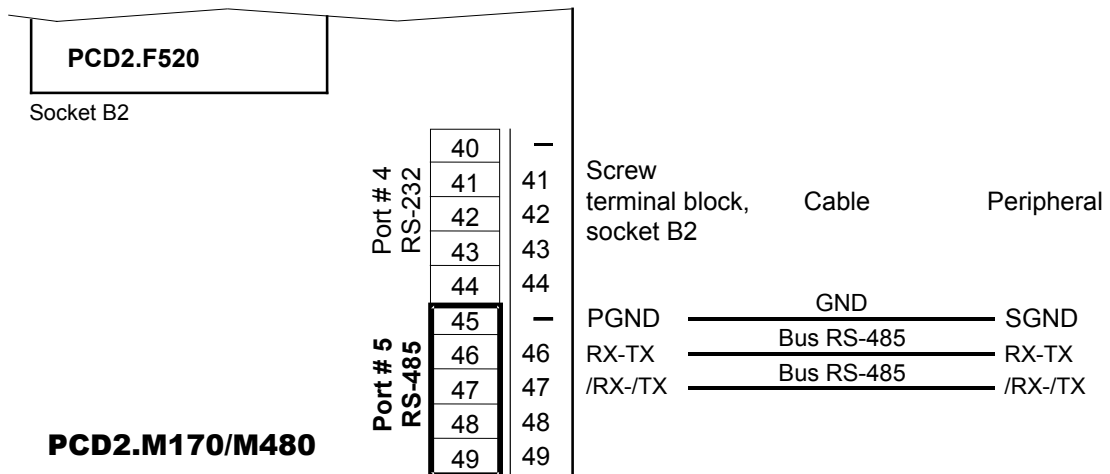

**RS-485 to D-Sub connector with PCD2.M170**

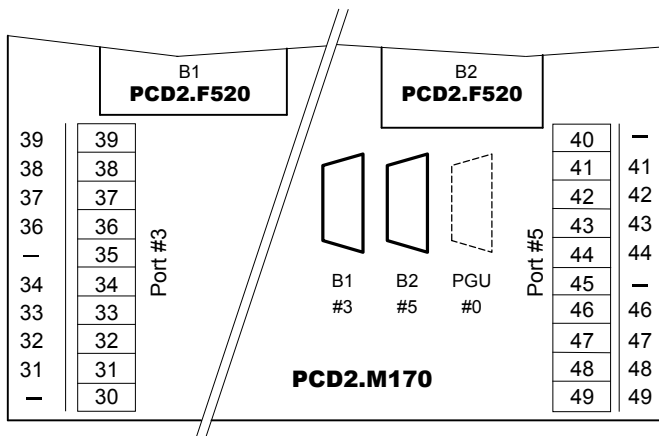

Assignment RS-485	Socket B1 Port#3 D-Sub Pin	Socket B2 Port#5 D-Sub Pin
PGND	1	1
-	2	2
/Rx-/Tx	3	3
-	4	4
-	5	5
-	6	6
-	7	7
Rx-Tx	8	8
-	9	9

4

**RS-485 to D-Sub connector with PCD2.M480**

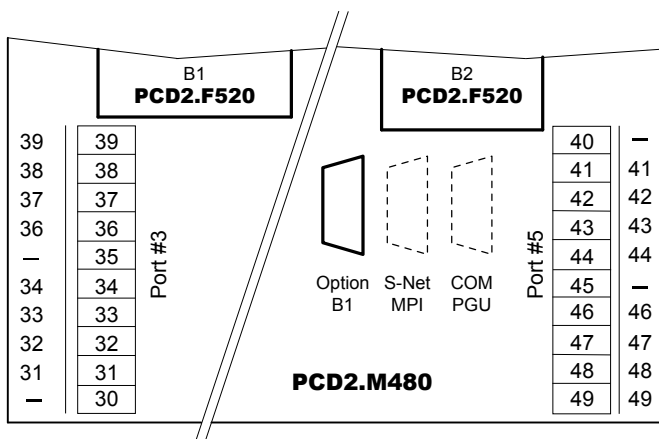

Assignment RS-485	Socket B1 Port#3 D-Sub Pin
PGND	1
-	2
/Rx-/Tx	3
-	4
-	5
-	6
-	7
Rx-Tx	8
-	9

**Connection diagram for RS-485 line termination resistors**

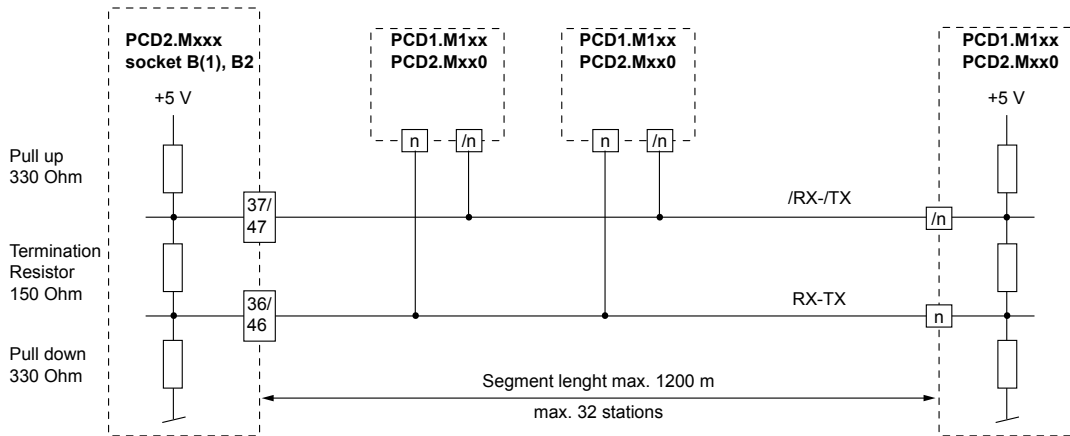

4



At the first and last stations, jumper J1 must be set to the “CLOSED” position. At all other stations, jumper J1 must be set to “OPEN” (factory setting)



For installation details, see manual 26/740 “Installation components for RS-485 networks”



The PCD7.F772 Profibus module (details in 4.8.3) and the PCD7.F802 LON module (details in 4.9) also have an RS-485 interface.

However, these modules are not supported by all PCD1/PCD2 units.

The wiring is identical to the RS-485 wiring for the PCD2.F520 Modules.

**4.7.2 RS-422 with PCD2.F520**

**RS-422: socket B(1) Port #3**

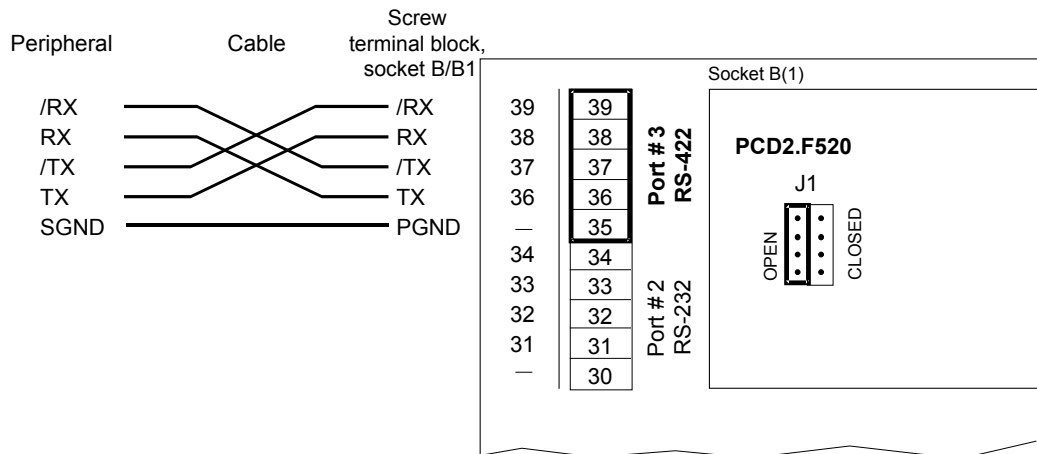



**RS-422: socket B2, Port#5 (M170/M480 only), for peripheral device**

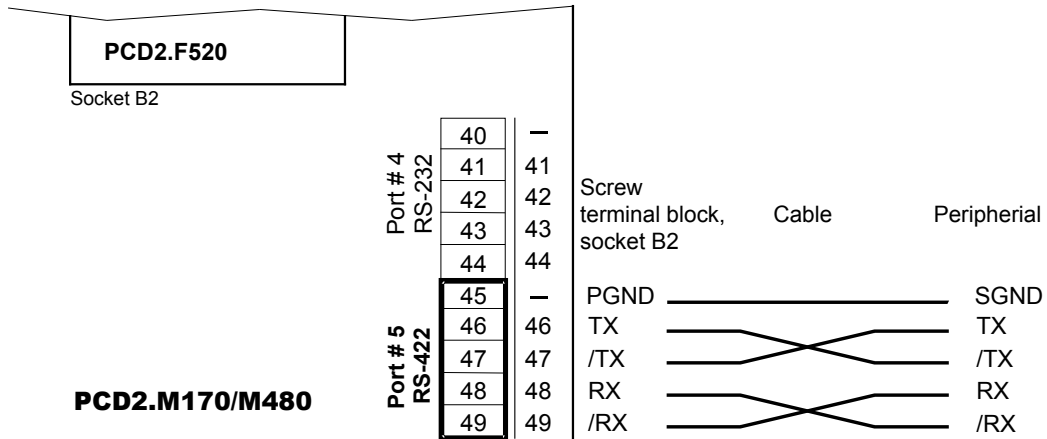

**RS-422 to D-Sub connector with PCD2.M170**

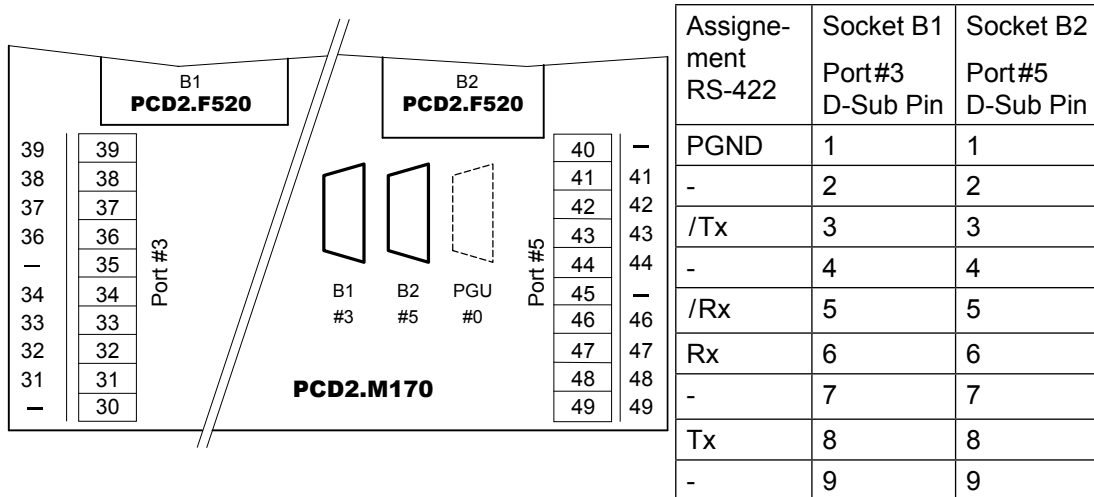

**RS-422 to D-Sub connector with PCD2.M480**

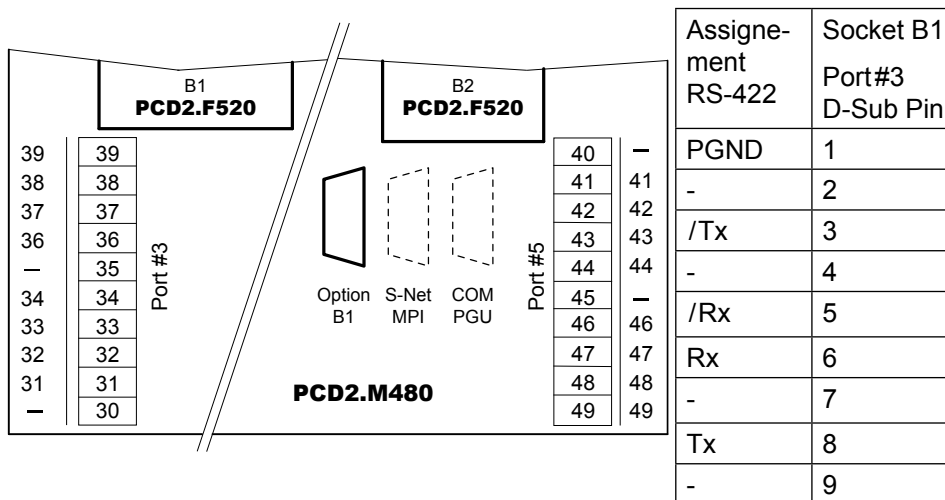

**4.7.3 RS-232 with PCD2.F520/F522**

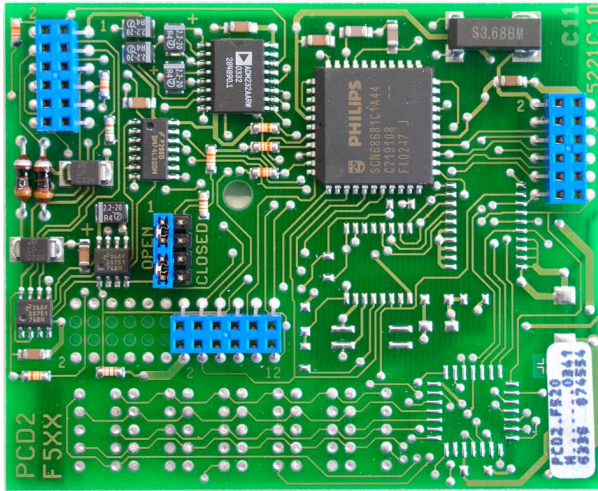

PCD2.F520:  
 1xRS-232 with RTS/CTS and  
 1xRS-485 electrically connected  
 or  
 1xRS-232 with RTS/CTS and  
 1xRS-422 without RTS/CTS  
 for socket B / B1/B2  
 not suitable for modem

4

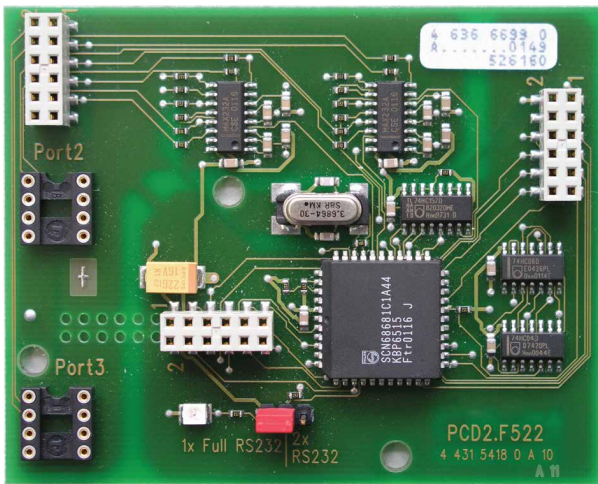

PCD2.F522:  
 choice between  
 2 × RS-232 with RTS/CTS  
 or  
 1 × RS-232 full with RTS/CTS,  
 DTR/DSR, DCD  
 Jumper for  
 2xRS-232 or  
 1xRS-232 full  
 suitable for modem connection for  
 socket B / B1/B

The PCD2.F520 and PCD2.F522 modules are only supported by PCD2.M120/M150/M170/M480 controllers.

**RS-232: socket B(1), Port#2, for peripheral device**

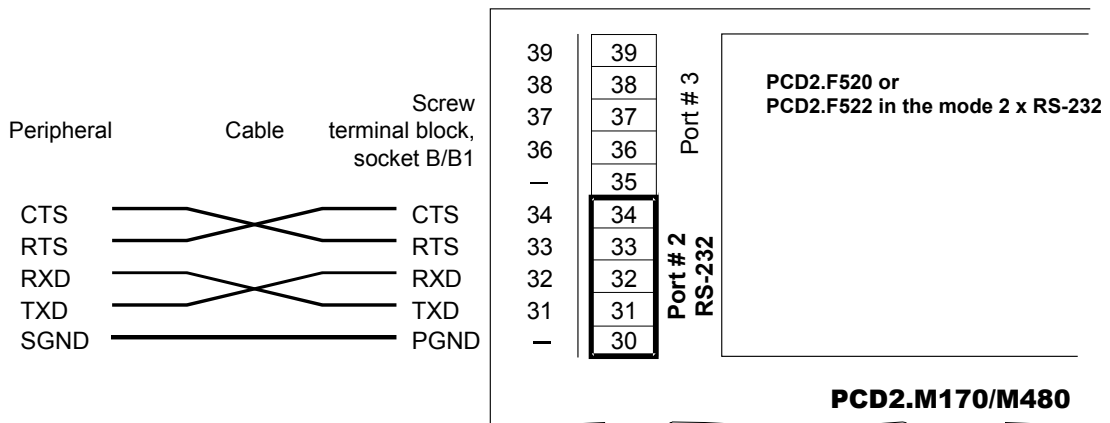

**RS-232: socket B(1), Port#3, for peripheral device**

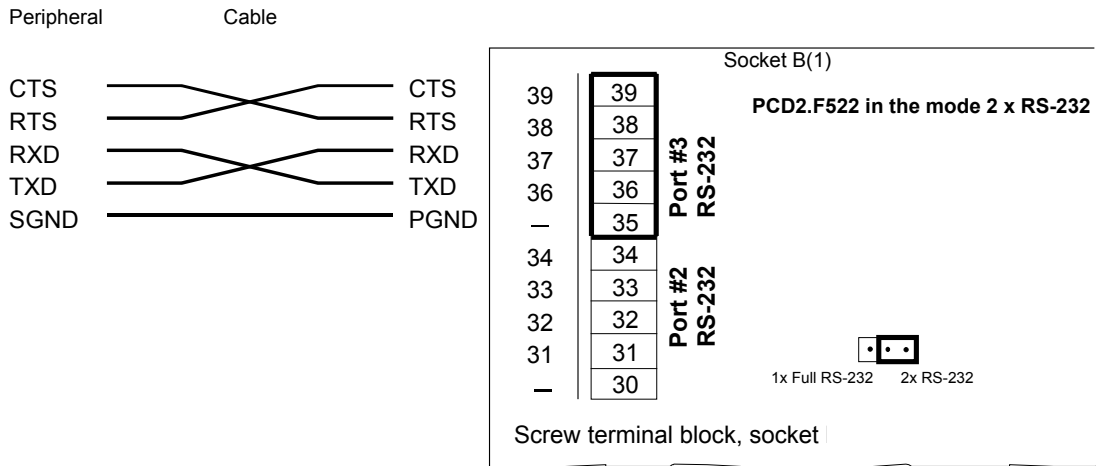

4

**RS-232: socket B2, Port#4 (M170/M480 only), for peripheral device**

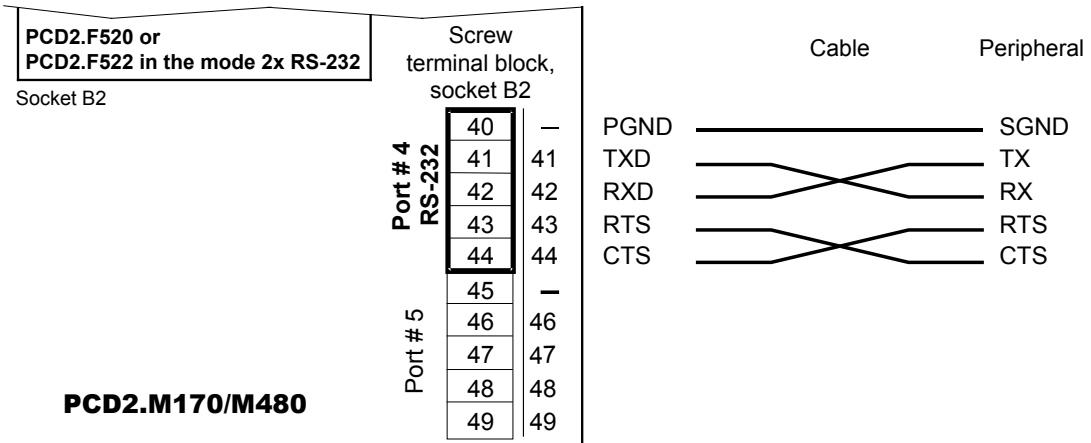

**RS-232: socket B2, Port#5 (M170/M480 only), for peripheral device**

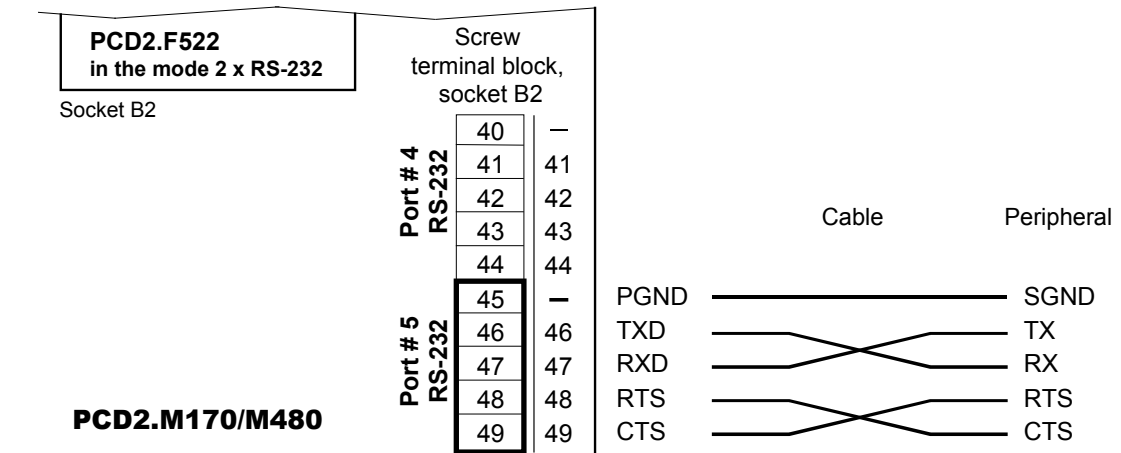

**RS-232 to D-Sub connector with PCD2.M170**

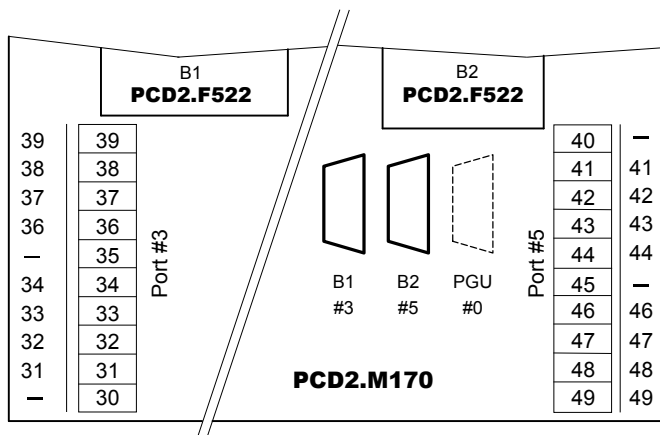

Assignment RS-232	B1 Port#3 D-Sub Pin	B2 Port#5 D-Sub Pin
PGND	1	1
-	2	2
RxD	3	3
-	4	4
CTS	5	5
RTS	6	6
-	7	7
TxD	8	8
-	9	9

4

**RS-232 to D-Sub connector with PCD2.M170**

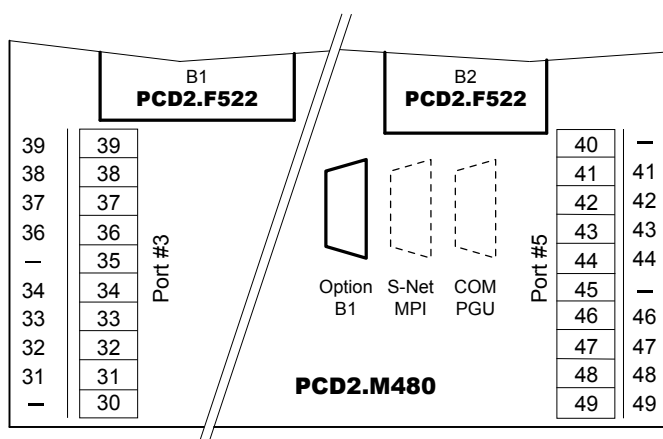

Assignment RS-422	B1 Port#3 D-Sub Pin
PGND	1
-	2
RxD	3
-	4
CTS	5
RTS	6
-	7
TxD	8
-	9



The DTR/DSR and DCD control lines are not present on these interfaces. If they are needed, e.g. to connect a modem, it is advisable to use the PCD7.F120 Module on socket A (Port# 1) or PCD2.F522 (in RS-232 full mode) on socket B1/B2.

**4.7.4 RS-232 full with PCD2.F522 (suitable for modem)**

**RS-232 full on socket B / B1, Port#2, for peripheral device**

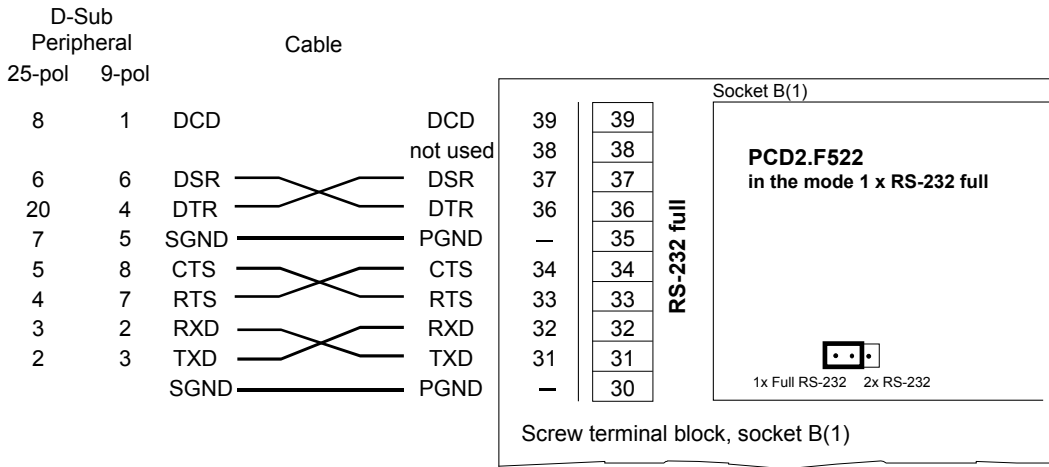

4

**RS-232 full on socket B2, Port#4 (M170/M480 only), for peripheral device**

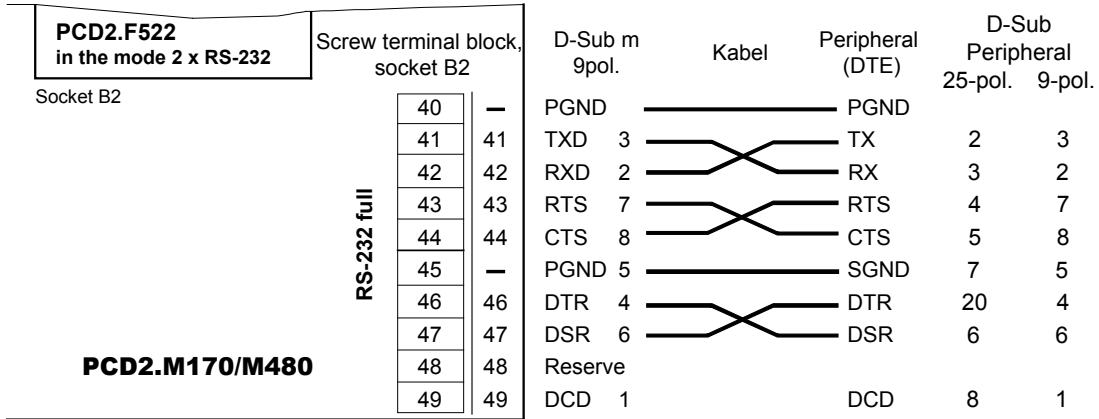

**RS-232 full on socket B1, Port#2, for external modem (DCE)**

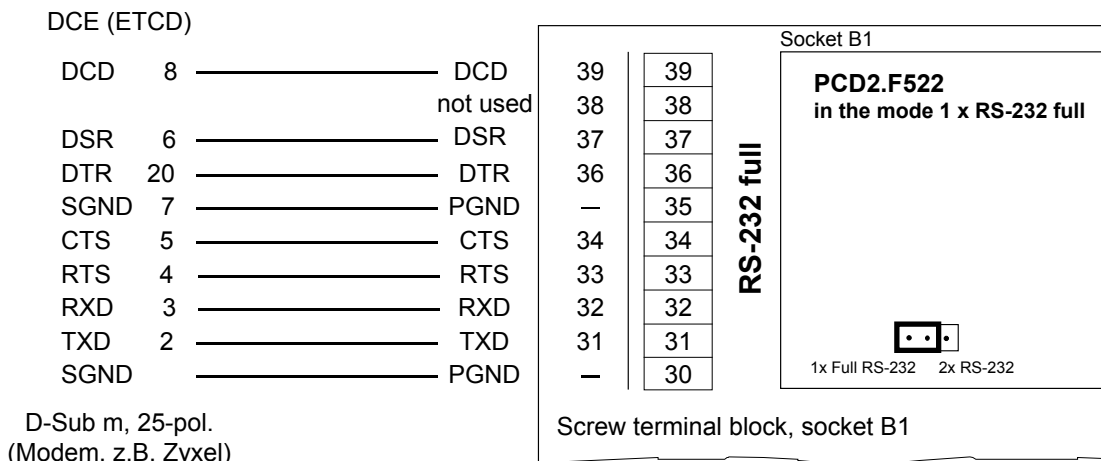

**RS-232 full on socket B2, Port#4 (M170/M480 only)  
for external modem (DCE)**

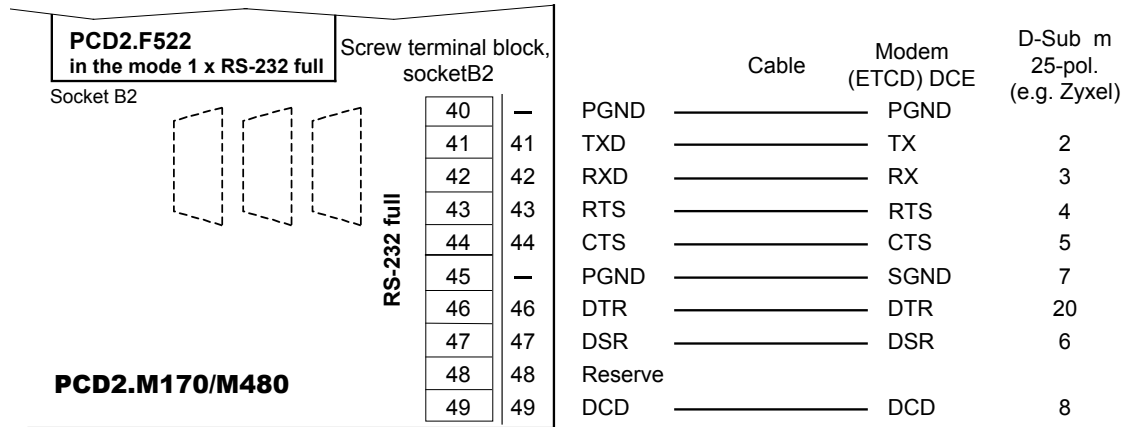

The jumper on the module must be in position 1x full RS-232.

## 4.8 Ethernet TCP/IP



PCD7.F655 \*  
Intelligent interface module for connection to Ethernet TCP/IP

4

\* The Ethernet modules PCD7.F650 and PCD7.F651 are no longer sold.



The Ethernet module is not supported on the PCD1.M110/M120 and PCD2.M110/M120. On the PCD2.M170, the module can only be operated on socket B2. On the PCD2.M480, 2 × Ethernet is supported.

Details can be found in manual 26/776 “Ethernet TCP/IP”.

## 4.9 Profibus

PCD7.F770

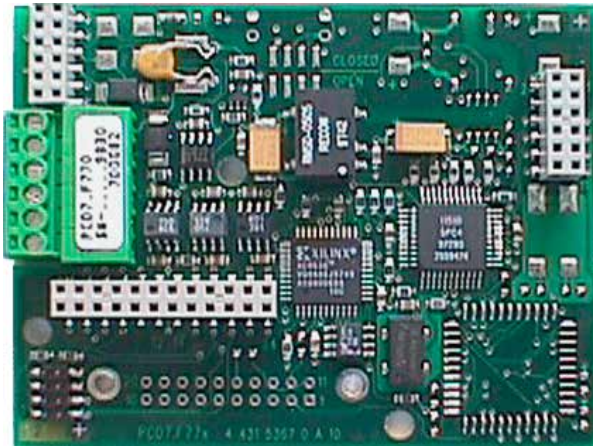

### **PCD7.F700**

for connection as Profibus FMS client/server

### **PCD7.F750**

for connection as Profibus DP Master

### **PCD7.F770**

for connection as Profibus DP Slave

### **PCD7.F772**

for connection as Profibus DP Slave, with electrically isolated RS-485 interface

4



Not all modules are supported by every Saia PCD®. The possible combinations are set out in tables

“4.2 Summary of PCD1 plug-in interface modules” and

“4.3 Summary of PCD2 plug-in interface modules”.



To avoid reflections, each segment must be terminated at the line ends. According to the Profibus standard, this must not be on the unit itself. For the termination boxes, either PCD7.T160s or normal 9-pole Profibus DP D-type connectors are suitable (on the M170/M480 only).

Details can be found in manual 26/765 “Profibus DP” or 26/742 “Profibus FMS”.



**4.9.1 Profibus DP Master, module PCD7.F750**

**PCD1.M120/M130 and PCD2.M120/M150**

The bus should be connected directly to the PCD7.F750 Module.

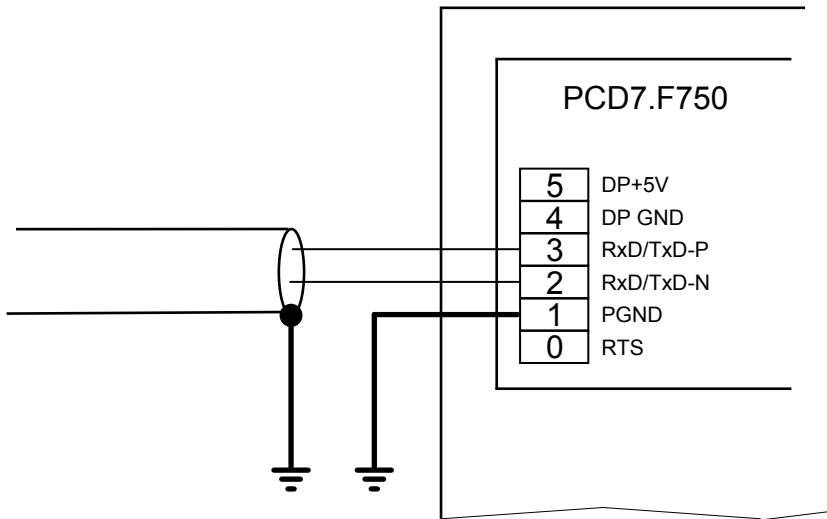

**PCD2.M170**

The bus should be connected to the D-Sub connector. The pin configuration is as per the Profibus standard. Alternatively the Profibus can be attached to the screw terminal block.

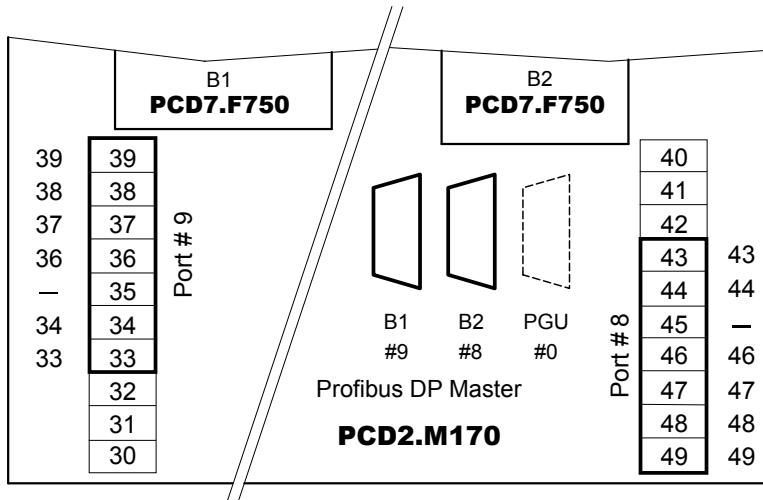

Socket	B1 Port#9		B2 Port#8	
	D-Sub	Screw terminal block	D-Sub	Screw terminal block
Kind of connection	9 pole	10 pole	9 pole	10 pole
Signal	Pin number	Terminal number	Pin number	Terminal number
RTS/CNTR-P	4	33	4	43
PGND	1	35	1	45
RxD/TxD-N	8	36	8	46
RxD/TxD-P	3	37	3	47
DP GND	5	38	5	48
DP +5 V	6	39	6	49

**PCD2.M480**

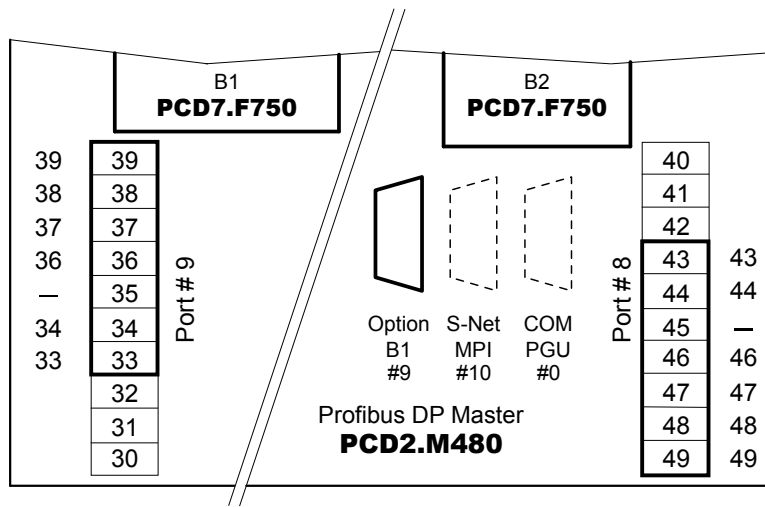

4

Socket	B1 Port#9		B2 Port#8
Kind of connection	D-Sub 9 pole	Screw terminal block 10 pole	Screw terminal block 10 pole
Signal	Pin number	Terminal number	Terminal number
RTS/CNTR-P	4	33	43
PGND	1	35	45
RxD/TxD-N	8	36	46
RxD/TxD-P	3	37	47
DP GND	5	38	48
DP +5 V	6	39	49

**4.9.2 Profibus DP Slave, module PCD7.F77x**

**PCD1.M120/M130 and PCD2.M120/M150**

The bus should be connected directly to the module PCD7.F770 or PCD7.F772.

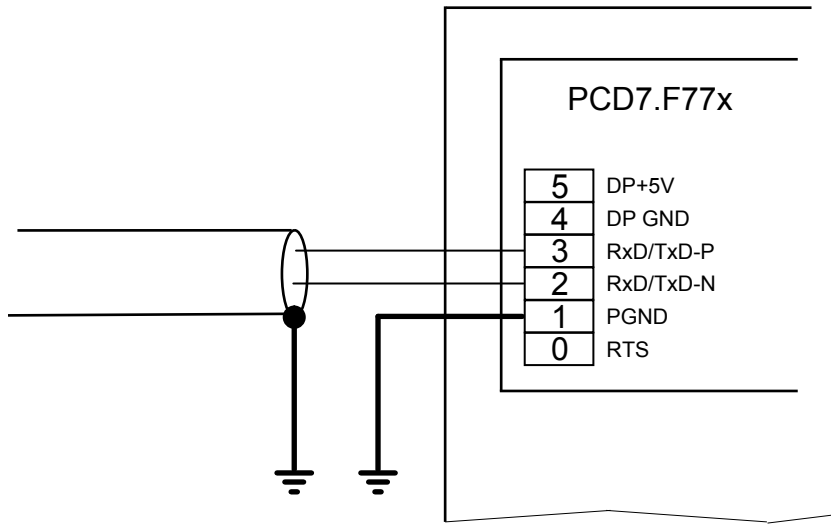

**PCD7.F770 with PCD2.M170**

The bus should be connected to the D-Sub connector. The pin configuration is as per the Profibus standard. Alternatively the Profibus can be attached to the screw terminal block.

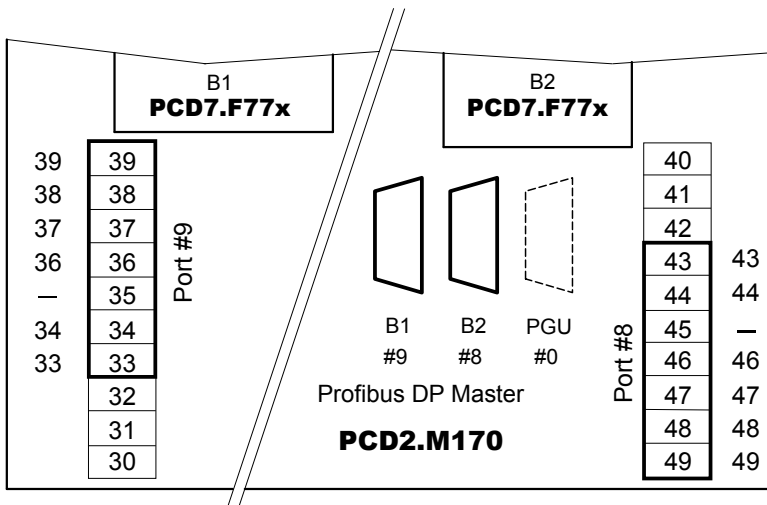

Socket	B1 Port#9		B2 Port#8	
	D-Sub	Screw terminal block	D-Sub	Screw terminal block
Kind of connection	9 pole	10 pole	9 pole	10 pole
Signal	Pin number	Terminal number	Pin number	Terminal number
RTS/CNTR-P	4	33	4	43
PGND	1	35	1	45
RxD/TxD-N	8	36	8	46
RxD/TxD-P	3	37	3	47
DP GND	5	38	5	48
DP +5 V	6	39	6	49

**PCD7.F772 with PCD2.M170**

Like PCD7.F770 however per module a serial interface RS-485 additionally.

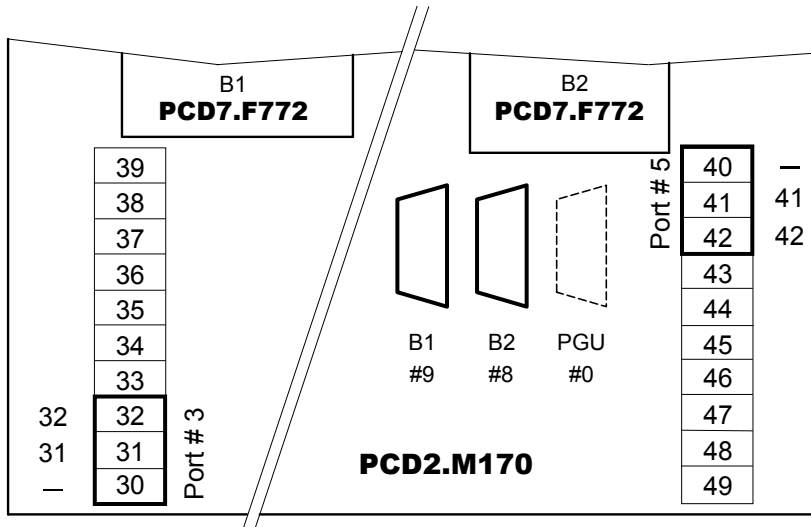

Socket	B1 Port#3	B2 Port#5
Kind of connection	Screw terminal block	Screw terminal block
Signal	Terminal number	Terminal number
/RX-/TX	32	42
RX-TX	31	41
PGND	30	40

**4.9.4 Profibus FMS, module PCD7.F700**

**PCD7.F700 with PCD2.M120/150**

The bus should be connected to the PCD2.

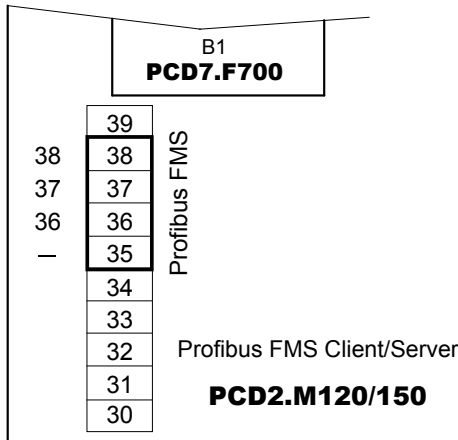

Socket	B1 FMS Client/Server
Kind of connection	Screw terminal block
	10 pole
Signal	Terminal number
DP GND	38
RxD/TxD-P	37
RxD/TxD-N	36
PGND	35

**PCD7.F700 with PCD2.M170**

The bus should be connected to the D-Sub connector. The pin configuration is as per the Profibus standard. Alternatively the Profibus can be attached to the screw terminal block.

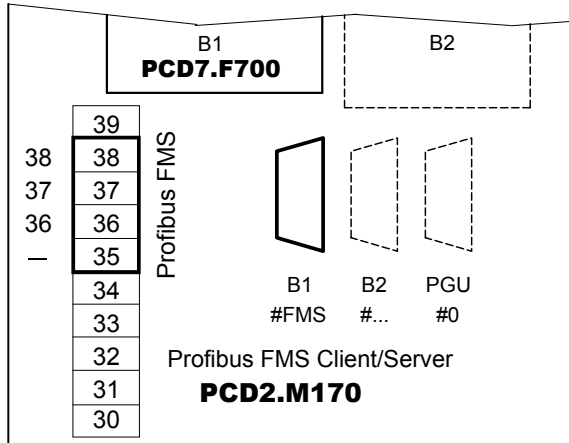

Socket	B1 FMS Client/Server	
Kind of connection	D-Sub	Screw terminal block
	9 pole	10 pole
Signal	Pin number	Terminal number
RxD/TxD-P	3	37
RxD/TxD-N	8	36
PGND	1	35
DP GND	5	38



There are no line termination resistors on this module. It is advisable to use an external termination box (e.g. PCD7.T160).

**4.10 LonWORKS® (freely configurable LON nodes)**

**PCD7.F800/F802**

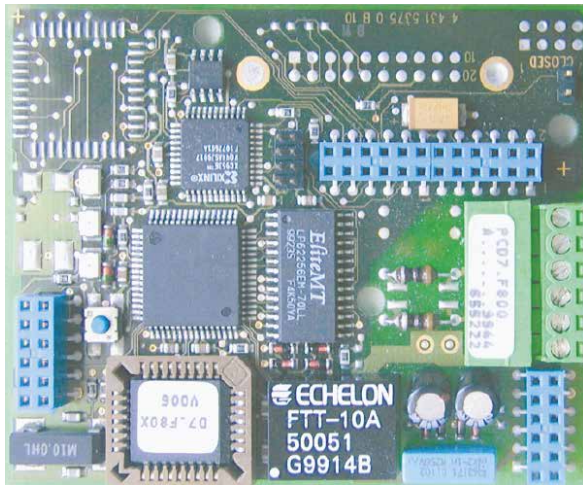

**PCD7.F800**

for connecting to the LonWORKS® network (free topology FTT-10)

**PCD7.F802**

for connecting to the LonWORKS® network (free topology FTT-10), with additional RS-485 serial port, electrically connected

4



Not all LON modules are supported by every Saia PCD®. The possible combinations are set out in tables 3.1 “Summary of PCD1 communication options” and 3.2 “Summary of PCD2 communication options”.

Details can be found in manual 26/767 “LON”.

**PCD1.M120/M130 and PCD2.M120/M150 LonWORKS® PCD7.F80x on socket B / B1**

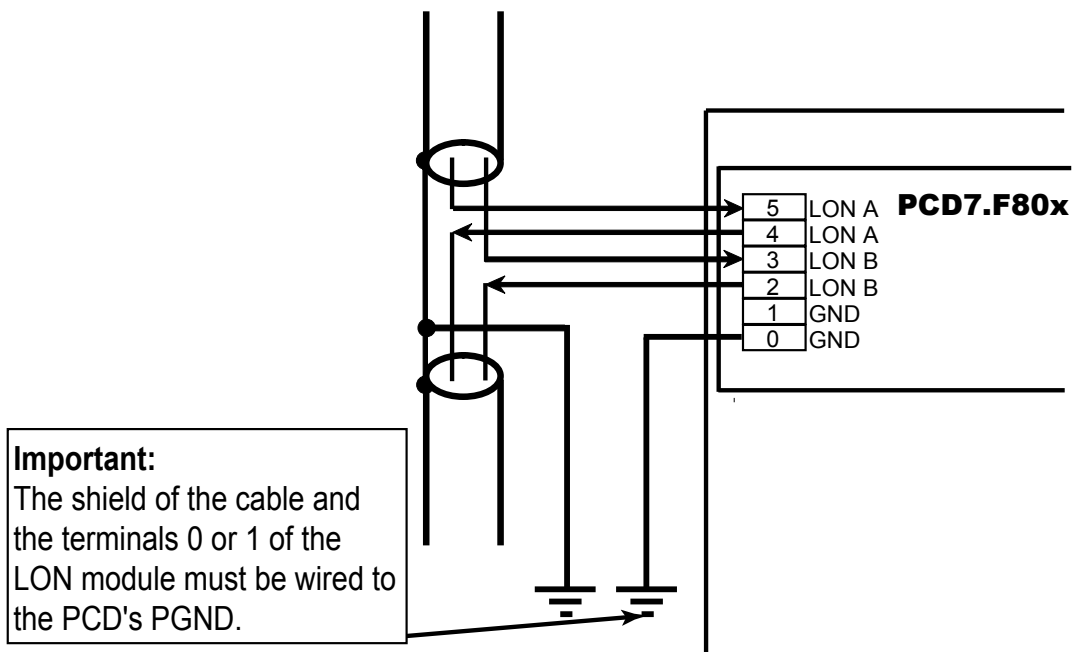

**LONWORKS® PCD7.F80x on PCD2.M170**

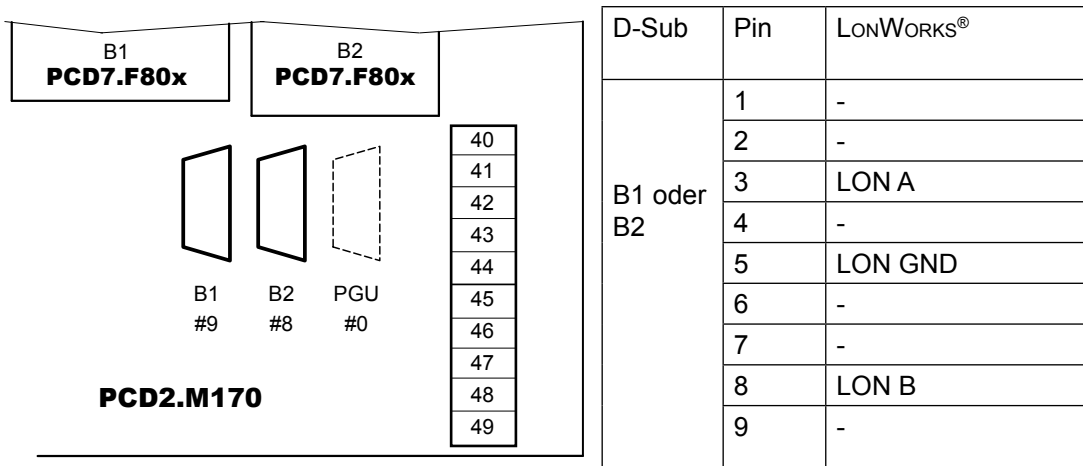

**RS-485 serial interface on PCD7.F802 on socket B1**

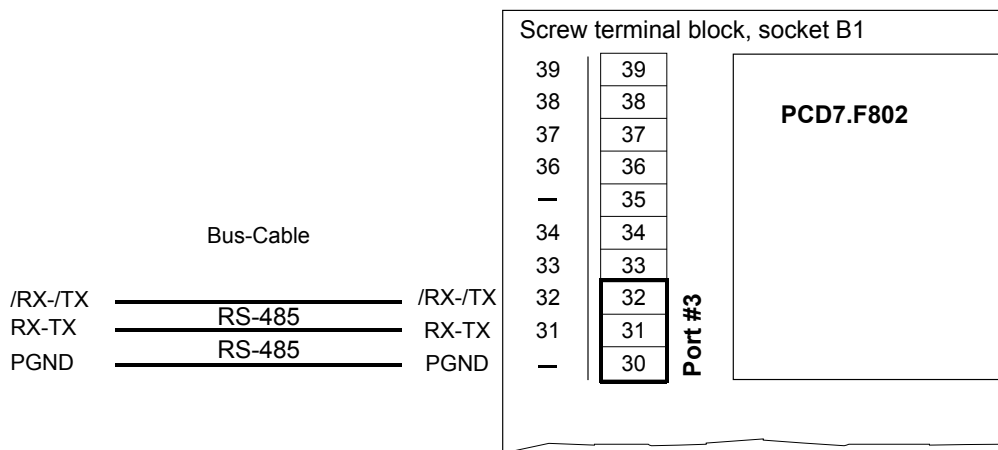

**RS-485 serial interface on PCD7.F802 on socket B2**

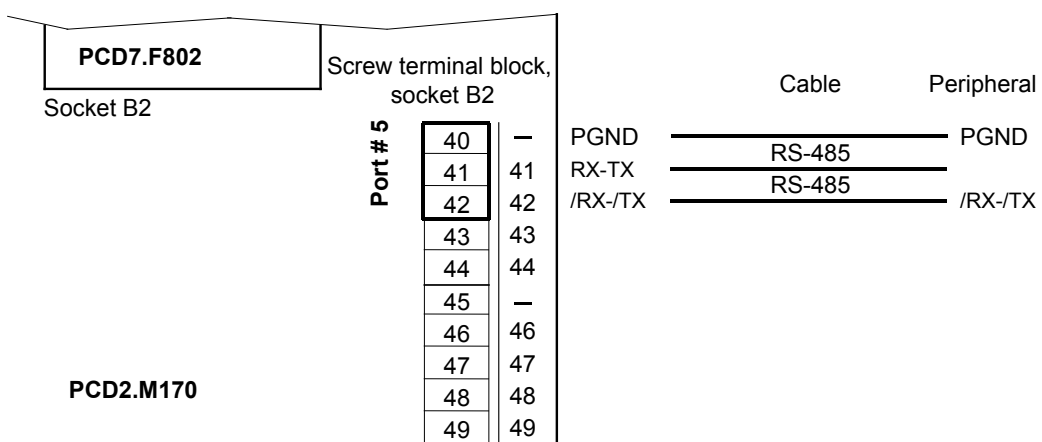



**4.11 Connection module for MP-Bus PCD2.T500**

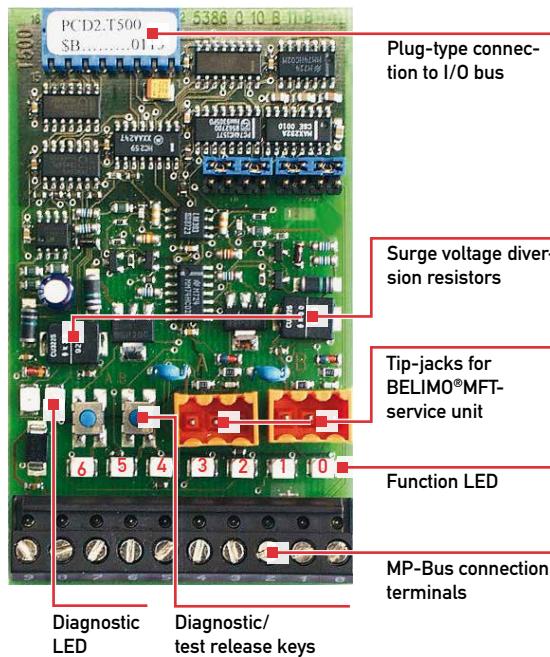

- Connection module for PCD1/PCD2 automation systems
- Can be plugged onto an I/O module socket
- 2 RS-232 or TTL communications channels
- 2 actuator connection channels, each for 8 MFT/MFT2 actuators and sensors
- Connection of very wide variety of sensors: passive and active sensors, 2-point sensor on actuator
- Integral monitoring of actuator function
- Extremely easy service check

**4.11.1 Communications signals**

The PCD2.T500 Module serves as an interface between the automation system (DDC-PLUS) and the MFT/MFT2 damper actuators from BELIMO Automation AG. The module can actuator up to two branches (bus connections) each having eight connected actuators. Each branch can be run asynchronously, independently of each other. To run both branches independently, the automation system will also require two logical communications channels (RS-232/TTL). However, if required, both branches can also be run on only one logical communications channel.

Data exchange is asynchronous and runs at 1200 pulses/second. The automation system leads the network as the “master”. The actuators have been designed as “slaves” and only communicate when instructed to do so by the master.

**4.11.2 Controls on PCD2.T500**

**Tip-jacks for MFT parameter setting unit from BELIMO®**

When the cover is removed from the controller, branches A and B can be provided with tip-jacks that allow connection of an MFT parameter setting unit from BELIMO®. As soon as the device is plugged in, the communications connection will automatically switch over from the connection module to the parameter setting unit. The controller is simultaneously informed of this fact, to avoid the appearance of a break in communications.

There are the following parameterization devices of BELIMO®:

Manual Control Unit	MFT-H	With its own power supply/batteries
PC-Tool	MFT-P	With the adapter ZIP-RS-232

**Diagnostic and test release keys**

For each branch a control key has been provided that triggers the start of a test for fault-free communications with all connected actuators.

**Diagnostic LED**

To the left of these keys are two LEDs (branch A on the left, branch B on the right) which, in association with the keys, indicate the result of a completed diagnosis. If a connected, addressed actuator does not communicate correctly with the Saia PCD® master station, the LED flashes. The number of flash signals matches the bus address of the actuator. They are repeated 5 times, with interruption.

**Function LED**

These LEDs are visible even when the cover is closed and indicate the following states:

4

LED	off	on
0	Channel 1 = Branch A Channel 2 = Branch B	Channel 1 = Branch B
1	Branch A is switched on	Branch A is switched off
2		Transmit signals at branch A
3		Transmit or receive signals at branch A
4	Branch B is switched on	Branch B is switched off
5		Transmit signals at branch B
6		Transmit or receive signals at branch B

**Base address**

The PCD2.T500 Module can be slotted into any I/O module socket on the PCD1/PCD2. The base address of the socket is required for software linking in the function boxes. For ease of wiring, it is recommended to choose a socket near to the communications ports.

**4.11.3 Connection and wiring**

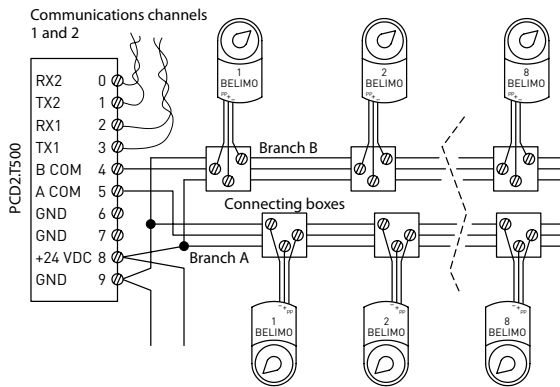

Terminal	Designation	Description	
0	Rx2	Receive line	Communications channel 2
1	Tx2	Transmit line	Communications channel 2
2	Rx1	Receive line	Communications channel 1
3	TX1	Transmit line	Communications channel 1
4	B Com	Communication branch B	
5	A Com	Communication branch A	
6	-	Earth connection for actuators, branches A and B	
7	-	Earth connection for actuators, actuators branches A and B	

8	+24 VDC	Module supply +
9	GND	Module supply - and earth connection

The supply voltage of the PCD1/PCD2 automation system is generally used to supply the PCD2.T500 Module. However, if preferred an external power source can also be used to supply the module and/or actuators. The following demands are placed on the supply voltage:

- 24 VDC  $\pm 20\%$  smoothed or
- 19 VAC  $\pm 15\%$  with full-wave rectifier and smoothing capacitor 10 000  $\mu\text{F}/40\text{V}$

#### 4.11.4 Supply possibilities

Common supply for controller and actuators

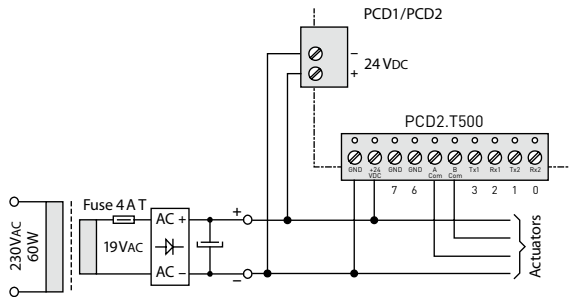

Separate supply of actuators with 24 VAC

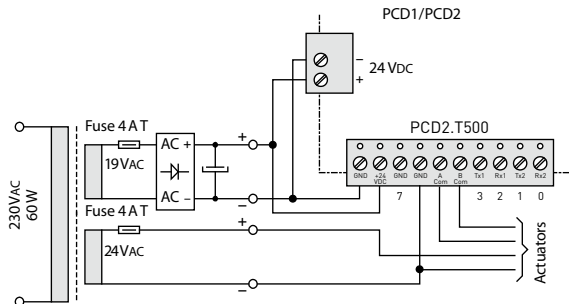

Individual DC supply for controller and actuators

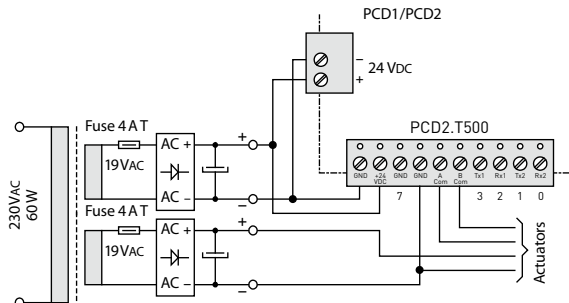

4.11.5 Configuration examples

Configuration example 1 with PCD1.M1xx

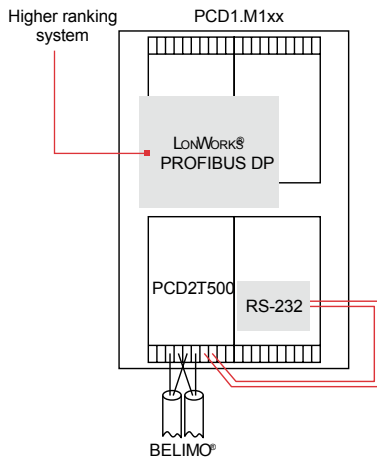

- PCD1.M1xx base unit
- Connection module assigned 1 × RS-232 communications interface (PCD7.F120 at space A) and 2 MP-Bus branches
- Gateway to other, higher ranking networks

Configuration example 2 with PCD2.M170

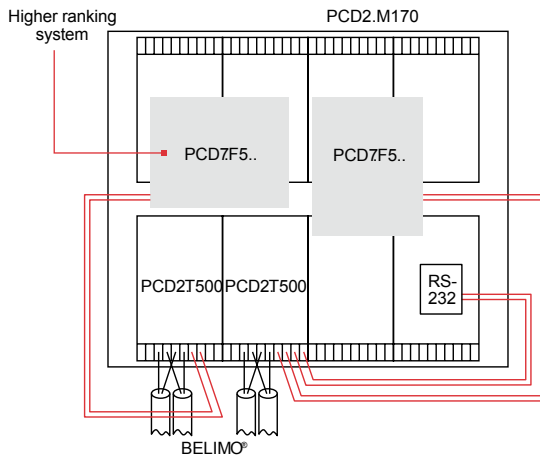

- PCD2.M170 base unit
- Connection module A assigned 1 × RS-232 communications interface and 2 MP-Bus branches
- Connection module B assigned 2 × RS-232 communications interfaces and 2 MP-Bus branches
- Gateway to other, higher ranking networks

Data exchange with DDC-PLUS systems

**Every connection module (PCD2.T500 or PCD7.F180) needs an RS-232 serial port for communication with the master station!** On the PCD2.T500 connection module, this port must be wired manually from the chosen Saia PCD® communications interface.

The PCD2.T500 connection module has two actuator branches (channel A and channel B) that can run both on one or two RS-232 transmission interfaces. The RS-232 interface connection at port 1 (terminals 2 and 3) will be for the first actuator branch and the RS-232 interface at port 2 (terminals 0 and 1) will be for the second actuator branch.

In projects that only have one RS-232 transmission interface within the Saia PCD®, both actuator branches (max. 16 actuators) can run on it. This involves a multiplexing process that switches between the two actuator branches. The fundamental rule applies that the more actuators are operated on one RS-232 serial transmission interface, the greater the load per branch.



In multiplex operation the communications times of all actuators on both branches must be added together to obtain the overall cycle time. See also the examples below.

**4.11.6 Communications times for MP-Bus**

For each instruction transmitted via the bus, an average communications time of approx. 150 milliseconds is required (a command always consists of an instruction and an answer). The following values are identical for both damper and valve actuators.

1. Example with one MFT(2) actuator

- The master sends a setpoint to the MFT(2) actuator (1st command).
  - The master reads the actual value from the MFT(2) actuator (2nd command).
- The entire communications process therefore comprises 2 commands of 150 ms = approx. 300 ms.

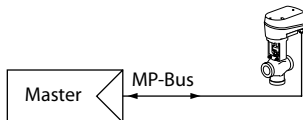

2. Example with two MFT(2) actuators

- The master sends one setpoint each to MFT(2) actuators 1...8 (total commands: 8).
- The master reads actual values from the MFT(2) actuators (total commands: 8).

The entire communications process therefore comprises 16 commands of 150 ms = approx. 2.4 s

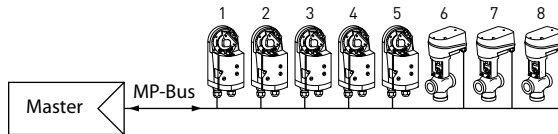

**4.11.7 Calculation of line length**

**Connection of MP-Bus**

- The network consists of a 3-wire connection (MP communication and 24 V supply).
- Special cable or line termination resistors are not required.
- Line lengths are limited
  - by the total power rating for all connected MFT/MFT2 actuators,
  - by the type of supply (24 VAC or 24 VDC via the bus)
  - and by the conductor cross-section.

Distance table for the MP-Bus	Supply	maximum line lengths with 1.5 mm <sup>2</sup> cable							
		5	10	15	20	25	30	35	40
Total power consumption [Watt]		5	10	15	20	25	30	35	40
max. line length*	24 VDC	300	150	100	85	60	50	42	38
	24 VAC	200	120	80	55	45	38	32	28

\* all distance data are approximately and can deviate from the local condition

- By bigger cross sections of the cable, the distances can be increased.
- The maximum length of 800 meters can be reached, when the drives are supplied locally via a separate transformer with 24 VAC

Further data concerning distances and connection types are offered by BELIMO Automation AG

**4.11.8 Maximum line length for 24 VAC supply**

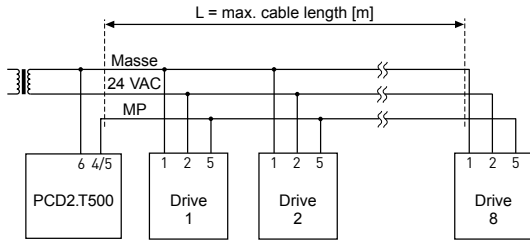

**Important:** For the NVF24-MFT2, dimensional output must be multiplied by a factor of 2.

**Determining maximum line lengths**

The dimensional outputs [VA] of all MFT (2) actuators used must be added together and the corresponding line lengths read from the diagram.

Example: 1 × NM.., 1 × AM.., 1 × AF.. and 1 × NV.. are connected to the MP-Bus.

Total dimensional output: 3 VA + 5 VA + 10 VA + 5 VA = 23 VA

**Total power consumption of MFT2 actuators [W]**

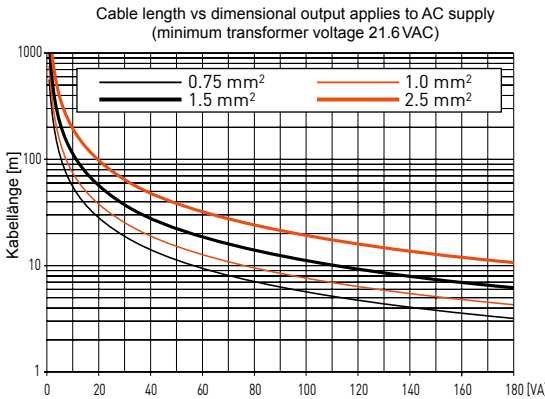

The following can be read from the family of curves:

- Cable with conductor Ø 0.75 mm<sup>2</sup> gives: Cable length 25 m
- Cable with conductor Ø 1.0 mm<sup>2</sup> gives: Cable length 33 m
- Cable with conductor Ø 1.5 mm<sup>2</sup> gives: Cable length 50 m
- Cable with conductor Ø 2.5 mm<sup>2</sup> gives: Cable length 85 m

**4.11.9 Maximum line length for 24 VDC supply**

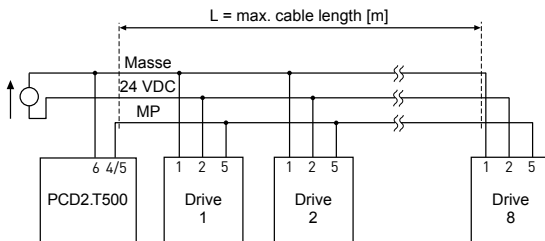

**Determining maximum line lengths**

Determining maximum line lengths The power consumption values [W] of all MFT/MFT2 actuators used must be added together and the corresponding line lengths read from the diagram.

Example: 1 × NM.., 1 × AM.., 1 × AF.. and 1 × NV.. are connected to the MP-Bus.

Total power consumption: 1.3 W + 2.5 W + 6.0 W + 3.0 W = 12.8 W

**Total power consumption of MFT2 actuators [W]**

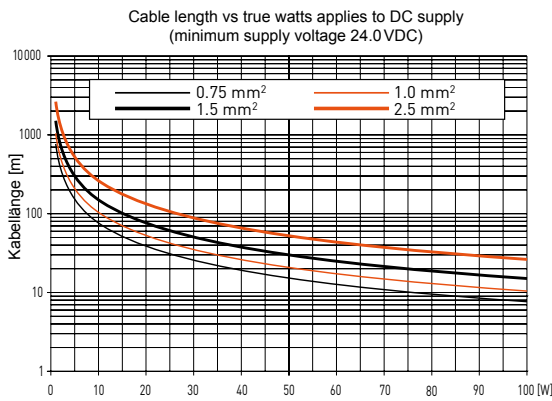

4

The following can be read from the family of curves:

- Cable with conductor 0.75 mm<sup>2</sup> gives: **Cable length 60 m**
- Cable with conductor 1.0 mm<sup>2</sup> gives: **Cable length 80 m**
- Cable with conductor 1.5 mm<sup>2</sup> gives: **Cable length 115 m**
- Cable with conductor 2.5 mm<sup>2</sup> gives: **Cable length 200 m**

**4.11.10 Maximum line length for 24 VAC supply (in situ)**

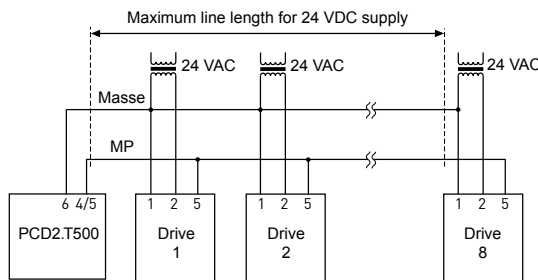

If the actuators are supplied locally with 24 VAC via a separate transformer, line lengths can be much increased. Regardless of the power ratings for the actuators connected, the line lengths will be according to the following table.

Conductor Ø	L = max. line length
0.75 mm <sup>2</sup>	800 m
1.0 mm <sup>2</sup>	800 m
1.5 mm <sup>2</sup>	800 m
2.5 mm <sup>2</sup>	800 m

## 5 Input/output (I/O) modules

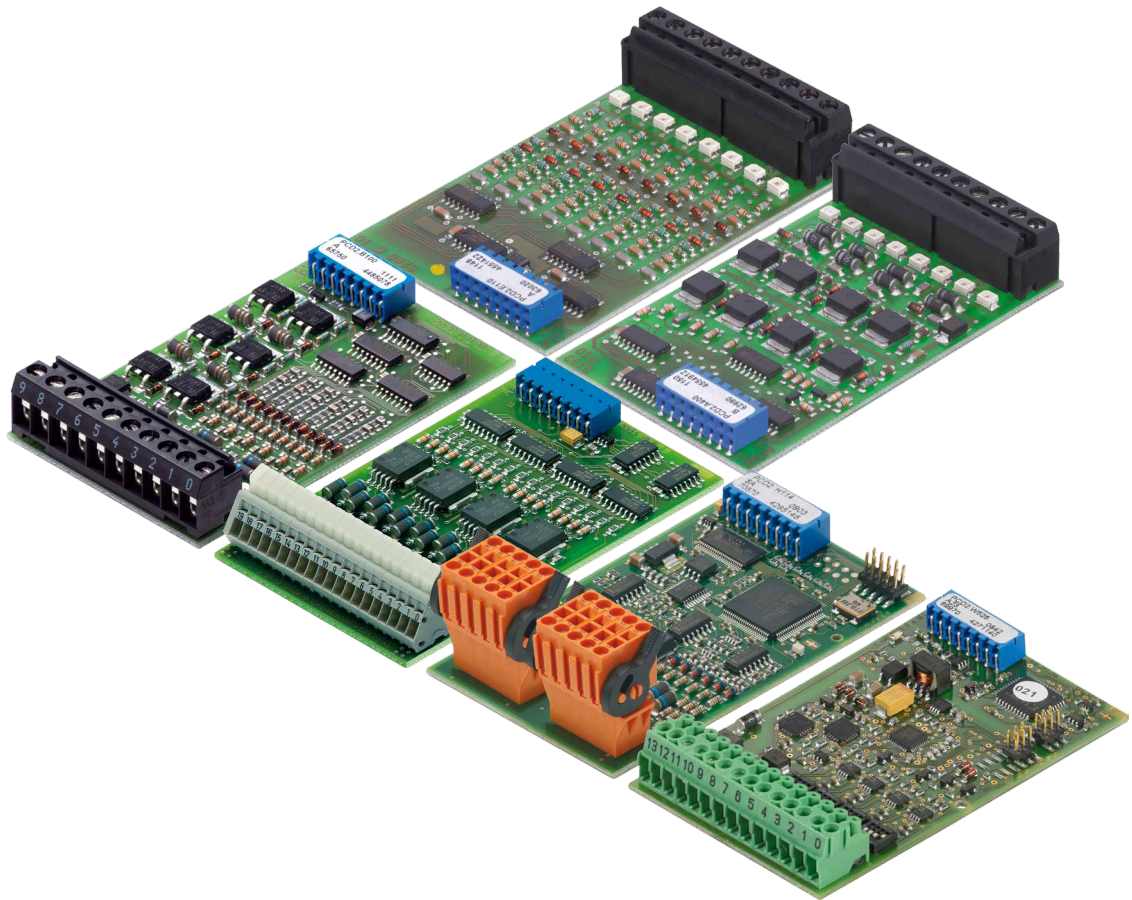

5

All I/O-modules for the series PCD1 and PCD2 are described in the manual 27-600.



## 6 System cables and adapters

### 6.1 System cables with I/O module connections to the Saia PCD®

The route to easy, fast connection is via these preconfigured cables. The connector is ready mounted at the Saia PCD® end of the cable, so it just has to be plugged in to connect. At the process end there are ribbon connectors to the terminal adapters or the relay interface, or 0.5 mm<sup>2</sup> or 0.25 mm<sup>2</sup> strands, numbered and colour-coded.

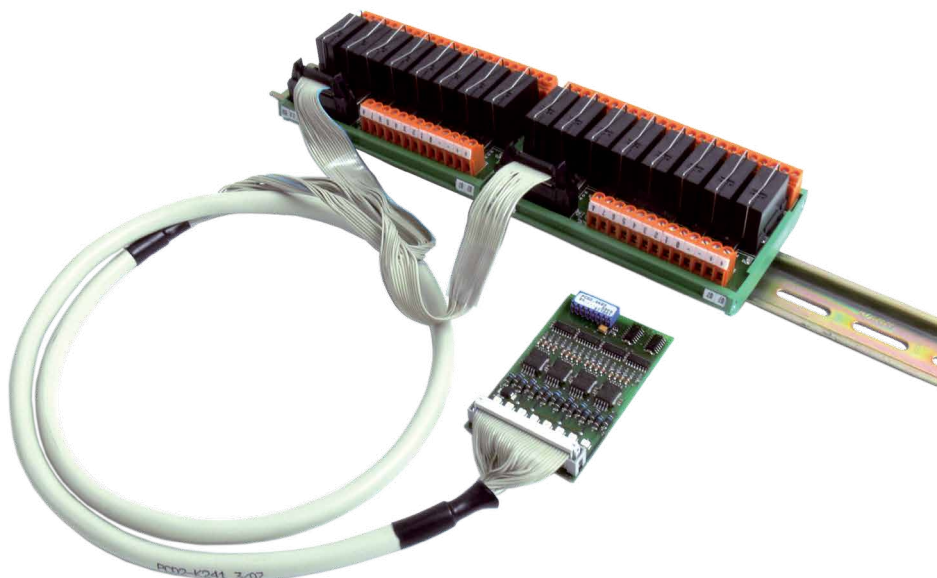

All the cables are described in the manual 26-792 connection system

## 7 Maintenance

PCD1 and PCD2 components are maintenance-free, apart from some CPUs (PCD1.M130 and PCD2.Mxxx), where the battery needs to be changed occasionally.

### 7.1 Changing the battery on the PCD1.M13x and PCD2.Mxxx CPUs

#### When is it necessary to change the battery?

The battery voltage is monitored by the CPU. The „Battery“ LED lights up and XOB 2 is called if

- the battery voltage is below 2.4 V or above 3.5 V
- the battery is flat or shows an interrupt
- the battery is missing

In these cases, the battery should be changed. We recommend changing the batteries with the Saia PCD® attached to the power supply, to avoid any loss of data.

CPU type	Buffer	Buffer time
PCD1.M110	Super Cap (soldered, maintenance-free)	30 days <sup>1)2)</sup>
PCD1.M120/M125	Super Cap (soldered, maintenance-free)	7 days <sup>2)</sup>
PCD1.M130/M135	CR 2032 lithium battery	1-3 years <sup>3)</sup>
PCD2.M110/M120 hardware version < H	2 × alkaline batteries size LR03/AAA/AM4/Micro	1-5 years <sup>3)</sup>
PCD2.M110/M120 hardware version ≥ H	CR 2032 lithium battery	1-3 years <sup>3)</sup>
PCD2.M150/M170/M480	CR 2032 lithium battery	1-3 years <sup>3)</sup>

1) The PCD1.M110 has no hardware clock, so the buffer time is greater than it is for the PCD1.M120

2) The total load time of the PCD1.M110, PCD1.M120 and PCD1.M125 amounts to approx. 30 minutes

3) Depending on the ambient temperature; the higher the temperature, the shorter the buffer time



The PCD1.M110, PCD2.M120 and PCD2.M125 CPUs have soldered-on buffer capacitors, making them **maintenance-free**.



Observe the polarity of the batteries:

- For alkaline batteries, the polarity can be seen on the socket
- Insert CR 2032 coin cell in such a way that the positive pole is visible



**Effect of changing the battery too late:**

- **all RAM contents are lost, i.e.**

- Resources (registers, flags, timers, counters etc.)
- Extension memory (text/DBs ≥ 4000)
- User program, if in RAM

- **The hardware clock (Real Time Clock) loses the current date**

- The date and the hour can be written after changing the battery with the «SBC Online Debug» in PG5.

For this the following command must be written:

**Write clock dd/mm/yy hh:mm:ss [week-of-year [day-of-week]] CR**

Changing the battery on the PCD1 and PCD2.Mxxx CPUs

The batteries are easy to locate on all CPU types. On the PCD2.M170 and PCD2.M480 the whole cover does not have to be removed; it is sufficient to open the battery compartment on the side to gain access to the battery.

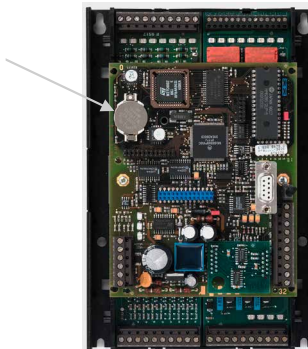

PCD1.M130/135

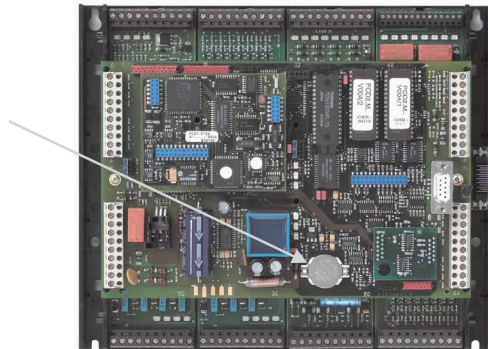

PCD2.M110/120/150

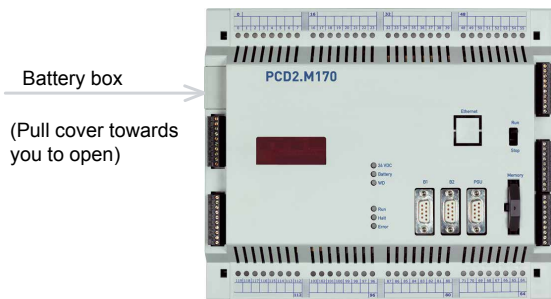

PCD2.M170/480

## 7.2 Updating firmware

### 7.2.1 Updating firmware on the PCD2.M110/M120

The firmware versions for the PCD2.M110/M120 are generally upwardly compatible in terms of hardware, so old CPUs can be fitted with new firmware, in order to take advantage of new functions. Unfortunately, we cannot guarantee to provide this feature in the future, but it has helped many customers in the past and we will try to retain it as long as possible.

At this point, the following known restrictions apply:

- Hardware version D1 from July/August 1995 only works with firmware version \$34; a firmware update is not possible with these controllers
- The use of intelligent communication modules such as Profibus DP, LON and Ethernet requires the minimum hardware and firmware versions. Please refer to the manuals for the communication modules

The firmware for the PCD2.M110/M120 is stored in two EPROMs. **With an EPROM burner (e.g. Galep-4), new firmware chips can be burned at any time.** The file with the latest firmware version is available to download from [www.sbc-support](http://www.sbc-support). Blank firmware chips can be obtained under item-no. 4 502 7126 0 (two chips per CPU need to be ordered).

### 7.2.2 Updating firmware on the PCD2.M150

The firmware versions for the PCD2.M150 are generally upwardly compatible in terms of hardware, so old CPUs can be fitted with new firmware, in order to take advantage of new functions. Unfortunately, we cannot guarantee to provide this feature in the future, but it has helped many customers in the past and we will try to retain it as long as possible.

The firmware for the PCD2.M150 is stored in two Flash EPROMs. **With an EPROM burner (e.g. Galep-4), new firmware chips can be burned at any time;** updating via download, as with the M170/M480 is not possible. The file with the latest firmware version is available to download from [www.sbc-support](http://www.sbc-support). Blank firmware chips can be obtained under item-no. 4 502 7341 0 (two chips per CPU need to be ordered).

### 7.2.3 Updating firmware on the PCD1.M1x5, PCD2.M170 and PCD2.M480

The firmware versions for the PCD1.M1x5, PCD2.M170 and PCD2.M480 are generally upwardly compatible in terms of hardware, so old CPUs can be fitted with new firmware, in order to take advantage of new functions. Unfortunately, we cannot guarantee to provide this feature in the future, but it has helped many customers in the past and we will try to retain it as long as possible.

The firmware for the PCD1.M1x5, PCD2.M170 and PCD2.M480 is stored in a Flash EPROM, soldered to the motherboard. A firmware update can be applied by downloading a new version within PG5. The procedure is as follows:





- Go to [www.sbc-support](http://www.sbc-support) and download the latest firmware version
- Establish a connection between the PG5 and the CPU, as for a download of an application (depending on the facilities available, serially via PGU cable, modem<sup>1</sup>), USB, Ethernet)
- Open the Online Configurator and go offline
- From the Tools menu, select “Update Firmware”, then use the Browse function to

select a path to the file for the new firmware version. Ensure that only one file is selected for downloading.

- Start the download
  - After the download, the power supply to the Saia PCD® must not be interrupted for 2 minutes, or the CPU may become blocked in such a way that it has to be sent back to the factory
- 1) A modem connection is not always reliable, and an on-site visit may be necessary. Other connection options are preferable

## A Appendix

### A.1 Icons

	<p>In manuals, this symbol refers the reader to further information in this manual or other manuals or technical information documents. As a rule there is no direct link to such documents.</p>
	<p>This symbol warns the reader of the risk to components from electrostatic discharges caused by touch. <b>Recommendation:</b> Before coming into contact with electrical components, you should at least touch the Minus of the system (cabinet or PGU connector). It is better to use a grounding wrist strap with its cable permanently attached to the Minus of the system.</p>
	<p>This sign accompanies instructions that must always be followed.</p>
	<p>Explanations beside this sign are valid only for the Saia PCD® Classic series.</p>
	<p>Explanations beside this sign are valid only for the Saia PCD® xx7 series.</p>

## A.2 Definitions of serial interfaces

### A.2.1 RS-232

Designation of signal lines:

Data lines	TXD	Transmit data
	RXD	Receive data
Signal and response circuits	RTS	Request to send
	CTS	Clear to send
	DTR	Data terminal ready
	DSR	Data set ready
	RI	Ring indicator
	DCD	Data carrier detect

### Signals to RS-232

Signal type	Logical state	Required value	Nominal value
Data signal	0 (space)	+3 V to +15 V	+7 V
	1 (mark)	-15 V to -3 V	-7 V
Control/ message signal	0 (off)	-15 V to -3 V	-7 V
	1 (on)	+3 V to +15 V	+7 V

The idle state  
of the data signals = "mark"  
of the control and message signals = "off"



**A.2.2 RS-485/422**

**Signals to RS-485 (RS-422)**

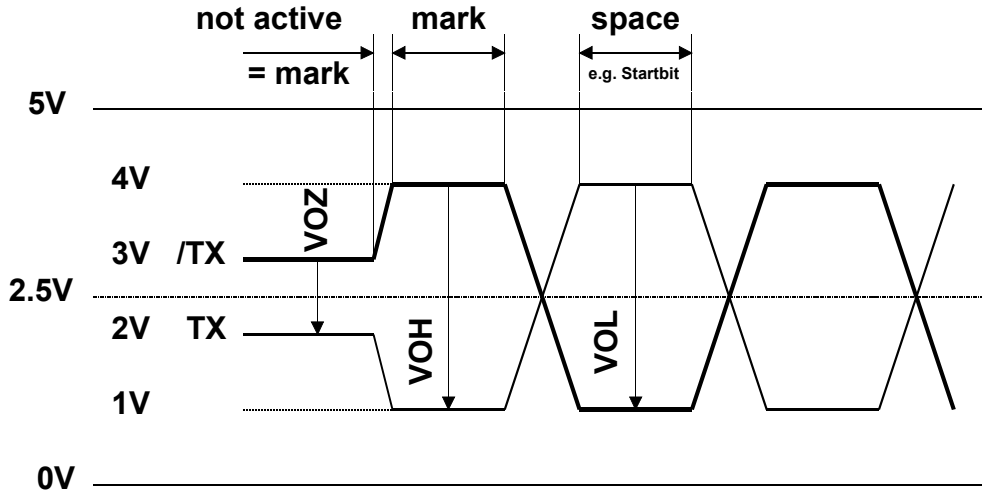

- VOZ = 0.9 V min ... 1.7 V
- VOH = 2 V min (with load) ... 5 V max (without load)
- VOL = -2 V ... -5 V

In the idle state, RS-422 is in the “mark” position

**RS-422:**



Signal type	Logical state	Polarity
Data signal	0 (space) 1 (mark)	TX positive to /TX /TX positive to TX
Control/ message signal	0 (off) 1 (on)	/RTS positive to RTS RTS positive to /RTS

**RS-485:**



Signal type	Logical state	Polarity
Data signal	0 (space) 1 (mark)	RX-TX positive to /RX-/TX /RX-/TX positive to RX-TX



Not all manufacturers use the same connection configuration, so the data lines may need to be crossed

To guarantee error-free operation of an RS-485 network, the network should be terminated at both ends. Cable and line termination resistors should be selected in accordance with manual 26/740 “Installation components for RS-485 networks”.



**A.2.3 TTY/current loop****Signals to TTY/current loop**

Terminal 11	TS	Transmitter Source	Transmitter
Terminal 13	TA	Transmitter Anode	
Terminal 16	TC	Transmitter Cathode	
Terminal 18	TG	Transmitter Ground	
Terminal 12	RS	Receiver Source	Receiver
Terminal 14	RA	Receiver Anode	
Terminal 17	RC	Receiver Cathode	
Terminal 19	RG	Receiver Ground	

Signal type	Required value	Nominal value
Power for logic L (space)	-20 mA to + 2 mA	0 mA
Power for logic H (mark)	+12 mA to +24 mA	+20 mA
Neutral voltage to TS, RS	+16 V to +24 V	+24 V
Short circuit power on TS, RS	+18 mA to +29.6 mA	+23.2 mA

The idle state of the data signals = “mark”

By wiring to the cable connector, the user selects either an “active” or “passive” circuit.



The max. transmission rate for 20 mA TTY/current loops is 9600 bps.

**A.3 Protocols on serial ports**

**A.3.1 Protocols supported by the firmware**

Protocol overview and support by firmware for the different CPUs	Purpose	Supported by				
		PCD1.M1xx	PCD2.M110 PCD2.M120	PCD2.M150 PCD2.M170	PCD2.M480	
<b>PGU with pin 6 (DSR)</b> of the PGU connector <b>set to logical “1”</b> (P800, Full Protocol)	Programming, debugging; replaced on newer releases by an equivalent function with S-Bus Parity mode	x	✓	x	x	
<b>PGU with pin 6 (DSR)</b> of the PGU connector <b>set to logical “1”</b> (Parity mode, Full Protocol)	Programming, debugging	✓ <sup>1)</sup>	x	✓ <sup>1)</sup>	✓ <sup>1)</sup>	
<b>S-Bus PGU</b> on the PGU port, with <b>pin 6 (DSR)</b> of the PGU connector <b>set to logical “0”</b> (Data, Parity or Break mode, Full Protocol)	Programming, debugging, visualization. Also allows access via gateway to stations within a different S-Bus network	✓ <sup>2)</sup>	✓ <sup>2)</sup>	✓ <sup>2)</sup>	✓ <sup>2)</sup>	
<b>Serial S-Bus</b> on any serial port (Data, Parity or Break mode)	Exchange of data with other controllers or with RIOs; previously called just S-Bus	✓ <sup>3)</sup>	✓ <sup>3)</sup>	✓ <sup>3)</sup>	✓ <sup>3)4)</sup>	
<b>Mode D</b> (reduced version of P800)	Exchange of data over point-to-point connections	✓ <sup>5)</sup>	✓ <sup>5)</sup>	✓ <sup>5)</sup>	x	
<b>Character mode</b> (MC1 to MC5)	Transmission of characters or text over serial ports; basis for creating own protocols in the user program	✓ <sup>6)</sup>	✓ <sup>6)</sup>	✓ <sup>6)</sup>	✓	

- 1) Requires the use of the PCD8.K111 programming cable
- 2) Requires an appropriate configuration in hardware settings
- 3) Requires an assignment of the port in the user program (SASI). For new applications, Data mode should always be selected. Exceptions: on PCD7.D7xx terminals, Parity mode is used
- 4) Break mode is not supported; Parity mode cannot be used on port 1
- 5) Obsolete; for new applications, use Serial S-Bus Data mode instead
- 6) MC5 Mode (RS-485 with immediate release of data line after transmission of the last character) requires the following minimum firmware versions:  
 PCD1.M1x0: V080  
 PCD2.M110/M120: V090  
 PCD2.M150: V0C0  
 PCD2.M170: V010



**A.3.2 Protocols implemented in the user program**

Based on Character mode (and a very good knowledge of LI programming), any desired protocols can be implemented.

Our system partners have already done this for a large number of protocols, enabling our controllers to communicate with components from a variety of manufacturers, e.g. via Modbus, M-Bus etc.



Please refer to the Links page at [www.sbc-support.com](http://www.sbc-support.com) for links to system partners.

**A.4 Order codes**

Type	Description	Weight
<i>Base units for 4 PCD2 I/O modules or modems</i>		
<b>PCD1.M110</b>	up to 64 I/Os, 1 port, 17 KBytes RAM, 16 MHz	920 g
<b>PCD1.M125</b>	up to 64 I/Os, up to 4 ports, 128 KBytes RAM, 16 MHz	920 g
<b>PCD1.M135</b>	up to 64 I/Os, up to 4 ports, 128 KBytes RAM, 25 MHz	920 g
<i>Base units for 8 PCD2 I/O modules or modems</i>		
<b>PCD2.M110</b>	up to 128 I/Os, 2 ports, 128 KBytes RAM, 16 MHz	860 g
<b>PCD2.M120</b>	up to 255 I/Os (with C100), up to 4 ports, 128 KBytes RAM, 16 MHz	920 g
<b>PCD2.M150</b>	up to 255 I/Os (with C100), up to 4 ports, 128 KBytes RAM, 25 MHz	920 g
<b>PCD2.M170</b>	up to 511 I/Os (with PCD3.LIO), up to 6 ports, 1 MByte RAM, 25 MHz	950 g
<b>PCD2.M480</b>	up to 1023 I/Os (with PCD3.LIO), up to 8 ports, 1 MByte RAM, latest $\mu$ C technology, 162 MHz (230 Mips)	950 g
<i>Expansion housings</i>		
<b>PCD2.C100</b>	for 8 additional I/O modules	560 g
<b>PCD2.C150</b>	for 4 additional I/O modules	350 g
<i>PCD3.RIO/LIO</i>		
<b>PCD3.C100</b>	for 4 PCD3 I/O modules	350 g
<b>PCD3.C110</b>	for 2 PCD3 I/O modules	180 g
<b>PCD3.C200</b>	for 4 PCD3 I/O modules, 24 VDC supply integrated	350 g
<b>PCD4.C225</b>	Coupling bus module with 2 module sockets for I/O modules from the PCD4 series	200 g
<b>PCD3.T760</b>	for 4 PCD3 I/O modules, Profibus DP, 24 VDC supply integrated	380 g
<b>PCD3.T765</b> <sup>1)</sup>	as PCD3.T760 + facility to implement user-specific software modules (plugins)	380 g
<i>PCD4 I/O bus modules</i>		
<b>PCD4.C220</b>	with 2 additional module sockets	375 g
<b>PCD4.C260</b>	with 6 additional module sockets	1100 g
<i>Extension cable for expansion housing/coupling bus module</i>		
<b>PCD2.K100</b>	Length 0.5 m (for mounting beneath each other with ..C1..., max. distance 150 mm)	65 g
<b>PCD2.K110</b>	Length 0.7 m (for mounting side-by-side with ..C1..)	70 g
<b>PCD2.K106</b>	Length 0.7 m ( PCD2.Mxx0 □ PCD3.LIO)	68 g
<b>PCD3.K010</b>	Connector (PCD3.LIO □ PCD3.LIO)	40 g
<b>PCD2.K120</b>	Length 2 m (for coupling bus module)	200 g
<b>PCD8.K111</b>	Connecting cable to PC with 9-pole connector (PC □ PGU)	200 g
<i>Additional memory components</i>		
<b>4 502 7013 0</b> <sup>2)</sup>	RAM chip with 128 KBytes/1 Mbit	12 g
<b>4 502 7175 0</b> <sup>2)</sup>	RAM chip with 512 KBytes/4 Mbit	12 g
<b>4 502 7126 0</b>	EPROM chip with 128 KBytes/1 Mbit	12 g
<b>4 502 7223 0</b>	EPROM chip with 512 KBytes/4 Mbit	12 g
<b>4 502 7141 0</b>	Flash EPROM chip with 128 KBytes/1 Mbit	12 g
<b>4 502 7224 0</b>	Flash EPROM chip with 512 KBytes/4 Mbit	12 g
<b>PCD7.R400</b>	Flash card with 1 MByte for PCD2.M170/M480, for backup	6 g

**A**

1) On request.

2) Where non-SBC RAM components are used, there is a risk of losing data.

Type	Description	Weight
<i>Communication modules</i> for socket A		
<b>PCD7.F110</b> <sup>3)</sup>	with RS-422/RS-485 interface (electrically connected)	8 g
<b>PCD7.F120</b> <sup>3) 5)</sup>	with RS-232 interface (suitable for modem)	8 g
<b>PCD7.F121</b> <sup>3)</sup>	with RS-232 interface (suitable for modem)	8 g
<b>PCD7.F130</b> <sup>3)</sup>	with interface for 20 mA current loop	8 g
<b>PCD7.F150</b> <sup>3)</sup>	with RS-485 interface (electrically isolated)	8 g
<b>PCD7.F180</b> <sup>3)</sup>	Belimo MP-Bus (based on RS-232)	8 g
<i>Function modules</i> for socket B(1)		
<b>PCD2.F520</b> <sup>3)</sup>	with RS-232 and RS-422/RS-485 serial interfaces (can also be installed on socket B2)	35 g
<b>PCD2.F522</b> <sup>3)</sup>	switchable between 2 × RS-232 and 1 × RS-232 (suitable for modem)	40 g
<b>PCD2.F530</b> <sup>3)</sup>	with 6-digit display and RS-232, RS-422 and RS-485 serial interfaces	45 g
<i>Field bus connections</i> for socket B(1) and B2		
<b>PCD7.F700</b> <sup>3)</sup>	Profibus FMS connection	45 g
<b>PCD7.F750</b> <sup>3)</sup>	Profibus DP connection (Master)	45 g
<b>PCD7.F770</b> <sup>3)</sup>	Profibus DP connection (Slave)	45 g
<b>PCD7.F772</b> <sup>3)</sup>	Profibus DP connection (Slave) and electrically isolated RS-485 interface	45 g
<b>PCD7.F800</b> <sup>3)</sup>	LONWORKS® connection	45 g
<b>PCD7.F802</b> <sup>3)</sup>	LONWORKS® connection and electrically isolated RS-485 interface	45 g
<b>PCD7.F655</b> <sup>3) 4)</sup>	Network connection with Ethernet module	45 g
<i>Modem modules</i> for I/O module socket		
<b>PCD2.T814</b>	33.6 kbps analogue modem (RS-232 and TTL interface)	50 g
<b>PCD2.T851</b>	ISDN-TA digital modem (RS-232 and TTL interface)	50 g
<i>Accessories</i>		
<i>Batteries</i>		
<b>4 507 4817 0</b>	CR 2032 lithium battery (coin cell), for PCD1.M135 and PCD2.Mxx0	10 g
From electrical dealers	Alkaline batteries, size LR03/AAA/AM4/Micro for PCD2.M110/PCD2.M120 hardware version < H	
<i>Housing covers</i>		
<b>4 104 7338 0</b>	Housing cover for PCD1 with space cut out for PCD7.D162 terminal	
<b>4 104 7409 0</b>	Housing cover for PCD1 with space cut out for RJ45 connector (TCP/IP)	
<b>4 104 7410 0</b>	Housing cover for PCD2.M150 with space cut out for RJ45 connector (TCP/IP)	
<i>Chips for firmware update</i>		
<b>4 502 7178 0</b>	PCD1 (order 1 per CPU)	15 g
<b>4 502 7126 0</b>	PCD2.M110/M120 (order 2 per CPU)	15 g
<b>4 502 7341 0</b>	PCD2.M150 (order 2 per CPU)	15 g
<i>Pluggable screw terminal blocks</i>		
<b>4 405 4847 0</b>	with 10 terminals (standard)	17 g
<b>4 405 4869 0</b>	with 14 terminals (for ..A250)	9 g



3) Please check compatibility with the base units in sections 4.1 and 4.2.  
 4) For PCD2.M170/M480 on socket B2, for PCD2.M150 on socket B with special housing cover 4 104 7410 0, or as configured system with type-no. PCD2.M150F655  
 5) Not recommended for new products..

Type	Description	Weight
	<i>Digital input modules</i>	
<b>PCD2.E110</b>	24 VDC, input delay typically 8 ms (pulsed voltage possible)	35 g
<b>PCD2.E111</b>	24 VDC, input delay typically 0.2 ms (smoothed voltage required)	35 g
<b>PCD2.E112</b>	12 VDC, input delay typically 8 ms (pulsed voltage possible)	35 g
<b>PCD2.E116</b>	5 VDC, input delay typically 0.2 ms (smoothed voltage required)	35 g
<b>PCD2.E160</b>	24 VDC, input delay typically 8 ms (pulsed voltage possible, connection via 34-pole system cable)	25 g
<b>PCD2.E161</b>	24 VDC, input delay typically 0.2 ms (smoothed voltage required, connection via 34-pole system cable)	25 g
<b>PCD2.E165</b>	24 VDC, input delay typically 8 ms (pulsed voltage possible, connection via 20-pole spring terminal block)	30 g
<b>PCD2.E166</b>	24 VDC, input delay typically 0.2 ms (smoothed voltage required, connection via 20-pole spring terminal block)	30 g
	<i>Digital input modules, electrically isolated</i>	
<b>PCD2.E500</b>	110...240 VAC, input delay typically 10 ms (electrically isolated)	55 g
<b>PCD2.E610</b>	24 VDC, input delay typically 10 ms (pulsed voltage possible)	40 g
<b>PCD2.E611</b>	24 VDC, input delay typically 1 ms (smoothed voltage required)	40 g
<b>PCD2.E613</b>	48 VDC, input delay typically 10 ms (pulsed voltage possible)	40 g
<b>PCD2.E616</b>	5 VDC, input delay typically 1 ms (smoothed voltage required)	40 g
	<i>Digital output modules</i>	
<b>PCD2.A300</b>	with 6 outputs 24 VDC/2 A	45 g
<b>PCD2.A400</b>	with 8 outputs 24 VDC/0.5 A	40 g
<b>PCD2.A460</b>	connection via 34-pole system cable	30 g
<b>PCD2.A465</b>	connection via 24-pole spring terminal block	35 g
	<i>Digital output modules, electrically isolated</i>	
<b>PCD2.A200</b>	with 4 make contacts 2 A/250 VAC or 2 A/50 VDC	60 g
<b>PCD2.A210</b>	with 4 break contacts 2 A/250 VAC or 2 A/50 VDC	60 g
<b>PCD2.A220</b>	with 6 make contacts 2 A/250 VAC or 2 A/50 VDC	65 g
<b>PCD2.A250</b>	with 8 make contacts 2 A/48 VAC or 2 A/50 VDC	65 g
<b>PCD2.A410</b>	with 8 outputs 24 VDC/0.5 A, electrically isolated	40 g
	<i>Combined digital input and output module</i>	
<b>PCD2.B100</b>	with 2 inputs and 2 transistor outputs, plus 4 selectable as inputs or outputs	45 g
	<i>Multi-functional I/O modules</i>	
<b>PCD2.G400</b>	10 digital inputs, 2 analogue inputs 10 bit, 6 analogue inputs 10 bit Pt/Ni 1000, 8 digital outputs, 6 analogue outputs 8 bit	79 g
<b>PCD2.G410</b>	16 digital inputs, 4 analogue inputs 10 bit, 4 relay outputs, 4 analogue outputs 8 bit	79 g

Type	Description	Weight
	<i>Analogue input modules</i>	
<b>PCD2.W100</b>	12 bit resolution, 4 input channels, 0...10 V, -10...0 V or -10...+10 V	40 g
<b>PCD2.W105</b>	12 bit resolution, 4 input channels, 0...20 mA, -20...0 mA or -20...+20 mA	40 g
<b>PCD2.W110</b>	12 bit resolution, 4 Pt100 input channels, each 2 mA (IEC751) <i>for resistive temperature sensors, Temperature range: -50...+150 °C</i>	50 g
<b>PCD2.W111</b>	12 bit resolution, 4 Ni100 input channels, each 2 mA (IEC43 760) <i>for resistive temperature sensors, Temperature range: -50...+150 °C</i>	50 g
<b>PCD2.W112</b>	12 bit resolution, 4 Pt1000 input channels, each 0.2 mA (IEC751) <i>for resistive temperature sensors, Temperature range: -50...+150 °C</i>	50 g
<b>PCD2.W113</b>	12 bit resolution, 4 Ni1000 input channels, each 0.2 mA (IEC43 760) <i>for resistive temperature sensors, Temperature range: -50...+150 °C</i>	50 g
<b>PCD2.W114</b>	12 bit resolution, 4 Pt100 input channels, each 0.2 mA (IEC751) <i>for resistive temperature sensors, Temperature range: 0...+350 °C</i>	50 g
<b>PCD2.W200</b>	10 bit resolution, 8 input channels, 0...10 V	35 g
<b>PCD2.W210</b>	10 bit resolution, 8 input channels, 0...20 mA	35 g
<b>PCD2.W220</b>	10 bit resolution, 8 input channels <i>for Pt/Ni1000 (2-wire) resistive temperature sensors, -50...+400 °C or +200 °C</i>	40 g
<b>PCD2.W220Z02</b>	Analogue input module, 8 inputs, 10 bits, NTC10 temperature sensors	40 g
<b>PCD2.W220Z12</b>	Analogue input module, 10 bits, 4 inputs 0...10 V and 4 inputs Pt/Ni 1000	40 g
<b>PCD2.W300</b>	12 bit resolution, 8 input channels, 0...10 V	40 g
<b>PCD2.W310</b>	12 bit resolution, 8 input channels 0...20 mA	40 g
<b>PCD2.W340</b>	12 bit resolution, 8 input channels, jumper selectable: 0...10 V, 0...20 mA or <i>for 2-wire resistive temperature sensors (Pt1000 for -50...+400 °C, or Ni1000 for -50...+200 °C)</i>	40 g
<b>PCD2.W350</b>	12 bit resolution, 8 input channels <i>for 2-wire resistive temperature sensors (Pt100 for -50...+600 °C, or Ni100 for -50...+250 °C)</i>	40 g
<b>PCD2.W360</b>	12 bit resolution, 8 input channels <i>for 2-wire resistive temperature sensors (Pt1000 for -50...+150 °C, resolution &lt; 0.1 °C)</i>	40 g
	<i>Analogue input modules, electrically isolated</i>	
<b>PCD2.W305</b>	12 bit resolution, 7 input channels 0...10 V	55 g
<b>PCD2.W315</b>	12 bit resolution, 7 input channels 0...20 mA	55 g
<b>PCD2.W325</b>	12 bit resolution, 7 input channels -10 V...+10 V	55 g
	<i>Analogue output modules</i>	
<b>PCD2.W400</b>	8 bit resolution, Simple module: 4 channels 0...10 V ( $\geq 3$ k $\Omega$ )	35 g
<b>PCD2.W410</b>	8 bit resolution, General purpose modules: 4 channels, jumper selectable, 0...10 V ( $\geq 3$ k $\Omega$ ) 0...20 mA ( $\leq 500$ k $\Omega$ ) or 4...20 mA ( $\leq 500$ k $\Omega$ )	45 g
<b>PCD2.W600</b>	12 bit resolution, Simple module: 4 channels 0...10 V ( $\geq 3$ k $\Omega$ )	40 g
<b>PCD2.W610</b>	12 bit resolution, General purpose modules: 4 channels, jumper selectable, 0...10 V and -10...+10 V ( $\geq 3$ k $\Omega$ ) 0...20 mA ( $\leq 500$ $\Omega$ ), further "mid/low" jumper to select switching sequence	45 g

Type	Description	Weight
	<i>Combined Analogue input and output modules</i>	
<b>PCD2.W500</b>	12 bit resolution, 2 input and 2 output channels for voltage signals	55 g
<b>PCD2.W510</b> <sup>1)</sup>	12 bit resolution, 2 input channels for current signals and 2 output channels for voltage signals	55 g
	<i>Combined Analogue input and output modules, electrically isolated</i>	
<b>PCD2.W525</b>	14 bit resolution, 4 input and 4 output channels	85 g
	<i>Analogue output modules, electrically isolated</i>	
<b>PCD2.W605</b>	10 bit resolution, Simple module: 6 channels 0... 10 V ( $\geq 3 \text{ k}\Omega$ )	60 g
<b>PCD2.W615</b>	10 bit resolution, Simple module: 4 channels 0... 20 V ( $\leq 500 \Omega$ )	60 g
<b>PCD2.W625</b>	10 bit resolution, Simple module: 6 channels -10 V... +10 V ( $\geq 3 \text{ k}\Omega$ )	60 g
	<i>Weighing modules</i>	
<b>PCD2.W710</b> <sup>1)</sup>	18 bit resolution, weighing module, 1 weighing system for up to 4 weighing cells	40 g
<b>PCD2.W720</b>	18 bit resolution, weighing module, 2 weighing systems for up to 6 weighing cells	45 g
	<i>Temperature modules</i>	
<b>PCD2.W745</b>	16 bit resolution, Temperature module for up to 4 measurement inputs	40 g
	<i>Fast counting counting I/O modules</i>	
<b>PCD2.H100</b>	Counting module up to 20 kHz	40 g
<b>PCD2.H110</b>	General purpose counting and measuring module up to 100 kHz	42 g
	<i>SSI encoder modules</i>	
<b>PCD2.H150</b>	SSI interface module	42 g
	<i>Positioning modules for stepping motors</i>	
<b>PCD2.H210</b>	Motion control module for one stepper motor axis	42 g
	<i>Positioning modules for servo-drives</i>	
<b>PCD2.H310</b> <sup>2)</sup>	Motion control module up to 100 kHz for servo-drives, 1 axis for 24 VDC encoder	48 g
<b>PCD2.H311</b> <sup>2)</sup>	Motion control module up to 100 kHz for servo-drives, 1 axis for 5 VDC/RS-422 encoder	48 g
<b>PCD2.H320</b>	Motion control module up to 125 kHz for servo-drives, 2 axes for 24 VDC encoder	66 g
<b>PCD2.H325</b>	Motion control module up to 125 kHz for servo-drives, 2 axes for 5 VDC/RS-422 encoder or SSI absolute angle transmitter (Slave only)	66 g
<b>PCD2.H322</b>	Motion control module up to 250 kHz for servo-drives, 1 axes for 24 VDC encoder	66 g
<b>PCD2.H327</b>	Motion control module up to 250 kHz for servo-drives, 1 axis for 5 VDC/RS-422 encoder or SSI absolute angle transmitter (Slave only)	66 g

A

1) Special version, supplied on request

2) Depending on the encoder, the 5 VDC supply may be loaded with up to 300 mA.

**A.5 Contact****Saia-Burgess Controls AG**

Bahnhofstrasse 18  
3280 Murten  
Switzerland

Phone ..... +41 26 672 72 72

Fax..... +41 26 672 74 99

Email support: ..... [support@saia-pcd.com](mailto:support@saia-pcd.com)

Supportsite: ..... [www.sbc-support.com](http://www.sbc-support.com)

SBC site: ..... [www.saia-pcd.com](http://www.saia-pcd.com)

International Representatives &

SBC Sales Companies: ..... [www.saia-pcd.com/contact](http://www.saia-pcd.com/contact)

**Postal address for returns from customers of the Swiss Sales office****Saia-Burgess Controls AG**

Service Après-Vente  
Bahnhofstrasse 18  
3280 Murten  
Switzerland

A