

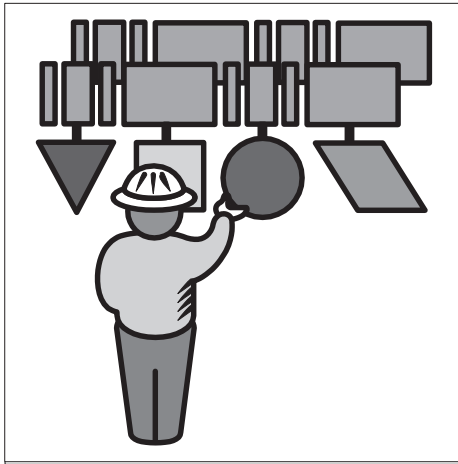

Allen-Bradley

*ControlNet
PLC-5
Programmable
Controllers*

*Cat. No. 1785-L20C,
-L40C, -L60C, -L80C*



Quick Start Phase 1.25

Important User Information

Because of the variety of uses for the products described in this publication, those responsible for the application and use of this control equipment must satisfy themselves that all necessary steps have been taken to assure that each application and use meets all performance and safety requirements, including any applicable laws, regulations, codes and standards.

The illustrations, charts, sample programs and layout examples shown in this guide are intended solely for purposes of example. Since there are many variables and requirements associated with any particular installation, Allen-Bradley does not assume responsibility or liability (to include intellectual property liability) for actual use based upon the examples shown in this publication.

Allen-Bradley publication SGI-1.1, *Safety Guidelines for the Application, Installation, and Maintenance of Solid-State Control* (available from your local Allen-Bradley office), describes some important differences between solid-state equipment and electromechanical devices that should be taken into consideration when applying products such as those described in this publication.

Reproduction of the contents of this copyrighted publication, in whole or in part, without written permission of Allen-Bradley Company, Inc., is prohibited.

Throughout this manual we use notes to make you aware of safety considerations:



ATTENTION: Identifies information about practices or circumstances that can lead to personal injury or death, property damage or economic loss.

Attention statements help you to:

- identify a hazard
- avoid the hazard
- recognize the consequences

Important: Identifies information that is critical for successful application and understanding of the product.

Preface

Read this preface to familiarize yourself with the rest of the manual. This preface covers the following topics:

- who should use this manual
- the purpose of this manual
- conventions used in this manual
- Rockwell Automation support

Who Should Use this Manual

Use this manual if you are new to the ControlNet PLC-5 processor.

For more information, refer to the publications listed in the Related Documentation section of this Preface, or contact your local Rockwell Automation representative.

Purpose of this Manual

This manual introduces you to installing and using a ControlNet PLC-5 processor system. In addition, it shows you how to set up a system using a typical configuration. Since this is a Quick Start manual, we do not cover all of the ControlNet PLC-5 processor features, but give you enough information to get you started.

This manual includes:

- basic information needed to start using the ControlNet PLC-5 processor quickly and effectively
- high-level procedures with cross-references to other manuals for more details

Important: The recommended switch settings in this manual help you set up a test system and get it working. Actual switch settings depend upon your application.

Related Documentation

The following documents contain additional information concerning the products discussed in this manual.

For more information about:	See this publication:	Publication number:
ControlNet PLC-5 programmable controllers (1785-L20C, -L40C, and -L80C)	ControlNet PLC-5 Programmable Controllers User Manual, phase 1.25	1785-6.5.14
	Enhanced and Ethernet PLC-5 Programmable Controllers User Manual	1785-6.5.12
	1785 Enhanced PLC-5 Processor System Overview	1785-2.36
	ControlNet System Overview	1786-2.9
	1785 PLC-5 Programmable Controllers Quick Reference	1785-7.1
	PLC-5 Programming Software Instruction Set Reference Manual	1785-6.1
ControlNet media	Industrial Automation Wiring and Grounding Guidelines	1770-4.1
	ControlNet Cable System Component List	AG-2.2
	ControlNet Cable System Planning and Installation Manual	1786-6.2.1
	ControlNet Coax Tap Installation Instructions	1786-2.3
	ControlNet Network Access Cable Installation Instructions	1786-2.6
Universal 1771 I/O chassis power supply (1771-P4S)	ControlNet Repeater Installation Instructions	1786-2.7
	Universal I/O Chassis installation instructions	1771-2.210
DH+ network	Power Supply Modules (1771-P4S, -P6S, -P4S1, -P6S1) installation instructions	1771-2.135
	Allen-Bradley Publication Index (for your specific power supply)	SD499
communication card (1784-KTC.x)	Enhanced and Ethernet Programmable Controllers User Manual	1785-6.5.12
	Data Highway/Data Highway Plus/Data Highway II/Data Highway-485 Cable installation instructions	1770-6.2.2
communication interface (1770-KFC)	ControlNet Communication Interface Card installation instructions	1784-5.20
	Allen-Bradley Publication Index (for your specific communication card)	SD499
terms and definitions	ControlNet Communication Interface User Manual	1770-6.5.20
	Industrial Automation Glossary	AG-7.1

Conventions Used in This Manual

The following conventions are used throughout this manual:

- Bulleted lists provide information, not procedural steps.
- Numbered lists provide sequential steps or hierarchical information.
- *Italic* type is used for emphasis.
- Text in `this font` indicates words or phrases you should type.
- Key names match the names shown and appear in bold, capital letters (for example, **ENTER**).



Tip: We use this convention to call attention to helpful information.

Rockwell Automation Support

Rockwell Automation offers support services worldwide, with over 75 Sales/Support Offices, 512 authorized Distributors and 260 authorized Systems Integrators located throughout the United States alone, plus Allen–Bradley representatives in every major country in the world.

Local Product Support

Contact your local Rockwell Automation representative for:

- sales and order support
- product technical training
- warranty support
- support service agreements

Technical Product Assistance

If you need to contact Rockwell Automation for technical assistance, call your local Rockwell Automation representative.

Your Questions or Comments on this Manual

If you find a problem with this manual, please notify us by completing and sending the enclosed Publication Problem Report (in the back of this manual).

If you have any suggestions for how this manual could be made more useful to you, please contact us at the address below:

Rockwell Automation/Allen–Bradley Company, Inc.

Control and Information Group

Technical Communication

1 Allen-Bradley Drive

Mayfield Heights, Ohio 44124-6118

Telephone: (440) 646-5000

FAX: (440) 646-3083

Table of Contents

Before You Begin	Chapter 1	
	Introduction	1-1
	Identify the Processor's Front Panel Components	1-1
	Check Your Components	1-2
Set Up the Hardware	Chapter 2	
	What You'll Be Doing in This Chapter	2-1
	Configure the I/O Chassis	2-2
	Ground the I/O Chassis	2-3
	Install the Power Supply	2-4
	Install the PLC-5 Processor	2-5
	Powerup the System	2-6
	Install the I/O Modules	2-6
	Connect the Personal Computer to the PLC-5 Processor	2-6
Set Up the Software	Chapter 3	
	Install the Software and Set Up the Programming System	3-1
	Start the Programming Software	3-1
	Power Up the System	3-1
Troubleshoot the Processor System	Chapter 4	
	Using This Chapter	4-1
	Using the General Status Indicators	4-1
	Using the ControlNet Status Indicators	4-3
	Using the DH+/RIO Status Indicators	4-5
	Monitoring ControlNet Configuration and Status	4-6
Processor Specifications	Appendix A	

Notes:

Before You Begin

Introduction

The ControlNet network is a high-speed link that lets PLC processors and I/O devices (e.g., I/O racks, variable speed drives, Human-Machine Interface (HMI), and other automation devices) exchange data. The ControlNet PLC-5 processors have one logical ControlNet port consisting of two BNC connectors and one network access port; these processors let you connect to the ControlNet network.

Identify the Processor's Front Panel Components

These pictures show the ControlNet PLC-5 processor front panel components.

PLC-5/20C Processor

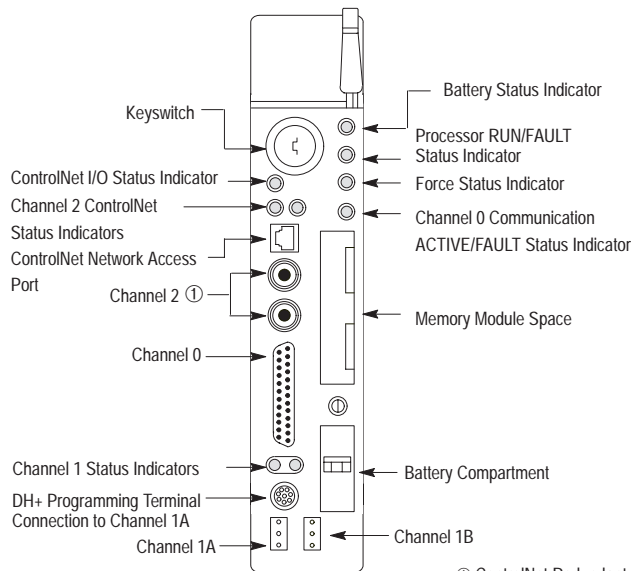

① ControlNet Redundant Media Ports— BNC; dedicated

PLC-5/40C, -5/60C, and -5/80C Processors

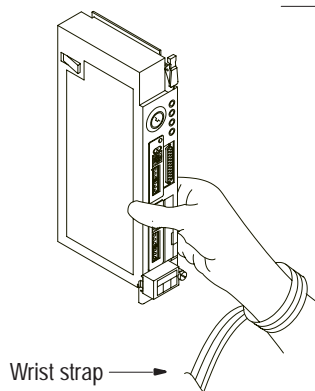
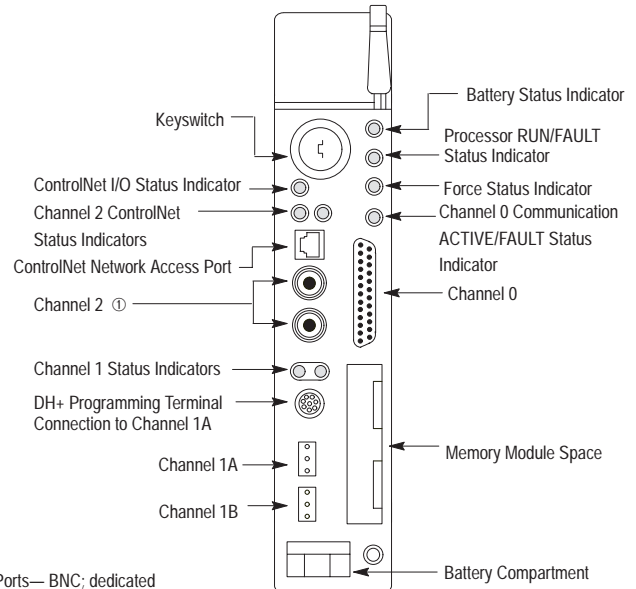

ATTENTION: Make sure you understand the anti-static environment.

The processor is shipped in a static-shielded container to guard against electrostatic damage. Electrostatic discharge can damage integrated circuits or semiconductors in the processor module if you touch backplane connector pins. It can also damage the module when you set configuration plugs or switches inside the module. Avoid electrostatic damage by observing the following precautions.

- Remain in contact with an approved ground point while handling the module (by wearing a properly grounded wrist strap).
- Do not touch the backplane connector or connector pins.
- When not in use, keep the module in its static-shielded container.

Check Your Components

For this quick start, you need this hardware and software:

Product name:	Catalog number:
Hardware	
ControlNet PLC-5 processor	1785-L20C, -L40C, L60C, -L80C
ControlNet network access cable	1786-CP
1771 I/O chassis	1771-A1B
power supply	1771-P4S
personal computer	your choice
communication interface card	1784-KTCx
Software	
RSLogix5 programming software	
6200 programming software	
RSLinx communication software	

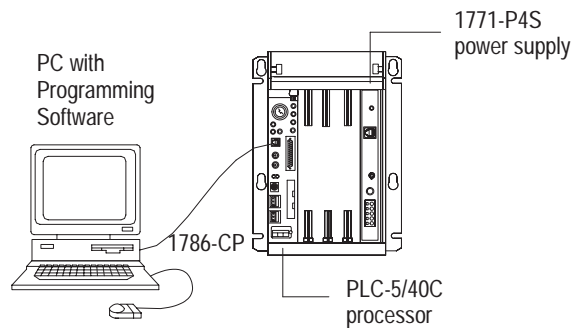

What You'll Be Doing In This Quick Start

This quick start describes how to:

- Set up the hardware
 - Configure the I/O chassis
 - Set the ControlNet network address
 - Install the hardware
 - Connect the personal computer
 - Connect your nodes to a ControlNet network
- Set up the software
 - Use 6200 programming software to enter network parameters and channel 2 configuration
- Troubleshoot the processor system

Compliance to European Union Directives

If this product has the CE mark it is approved for installation within the European Union and EEA regions. It has been designed and tested to meet the following directives.

EMC Directive

This product is tested to meet Council Directive 89/336/EEC Electromagnetic Compatibility (EMC) and the following standards, in whole or in part, documented in a technical construction file:

- EN 50081-2 EMC – Generic Emission Standard, Part 2 – Industrial Environment
- EN 50082-2 EMC – Generic Immunity Standard, Part 2 – Industrial Environment

This product is intended for use in an industrial environment.

Low Voltage Directive

This product is tested to meet Council Directive 73/23/EEC Low Voltage, by applying the safety requirements of EN 61131-2 Programmable Controllers, Part 2 – Equipment Requirements and Tests.

For specific information required by EN 61131-2, see the appropriate sections in this publication, as well as the following Allen-Bradley publications:

- Industrial Automation Wiring and Grounding Guidelines For Noise Immunity, publication 1770-4.1
- Guidelines for Handling Lithium Batteries, publication AG-5.4
- Automation Systems Catalog, publication B111

This equipment is classified as open equipment and must be installed (mounted) in an enclosure as a means of providing safety protection.

Notes

Set Up the Hardware

What You'll Be Doing in This Chapter

This chapter explains how to:

- Configure the I/O chassis
- Ground the I/O chassis
- Install the power supply
- Install the PLC-5 processor
- Power up the system
- Install the I/O modules
- Connect the personal computer to the PLC-5 processor

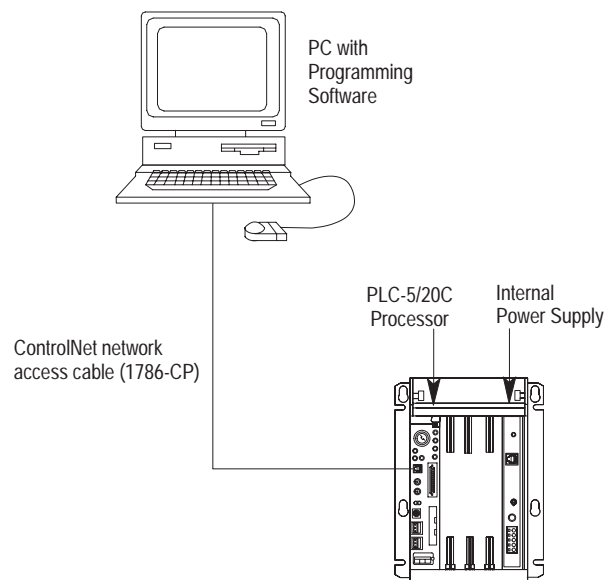

Install the Hardware

Configure the I/O Chassis

1 Set the backplane switches.

- Pressed in at top ON (closed)
- Pressed in at bottom OFF (open)

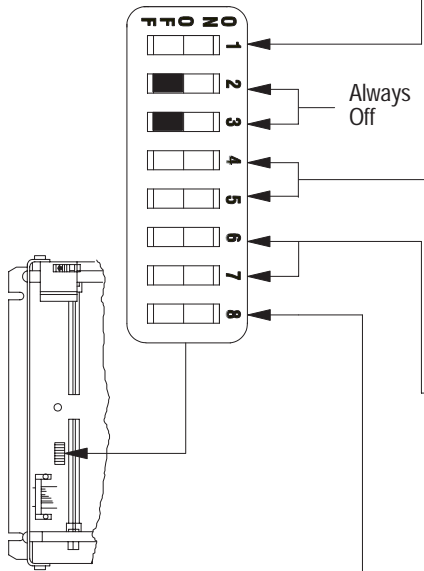

Switch	Last State
1	
on	Outputs of this I/O chassis remain in their last state when a hardware failure occurs. ①
off	Outputs of this I/O chassis are turned off when a hardware failure occurs. ①

Switches		Addressing
4	5	
off	off	2-slot
off	on	1-slot
on	off	1/2-slot
on	on	Not allowed

Switches		EEPROM Transfer
6	7	
off	off	EEPROM memory transfer to processor memory at power-up. ② ③
on	on	EEPROM memory transfers to processor memory if processor memory not valid.
on	off	EEPROM memory does not transfer to processor memory. ④

Switch	Processor Memory Protection
8	
off	Processor memory protection disabled.
on	Processor memory protection enabled. ⑤

- ① Regardless of this switch setting, outputs are turned off when any of the following occurs:
 - processor detects a runtime error
 - an I/O chassis backplane fault occurs
 - you select program or test mode
 - you set a status file bit to reset a local rack
- ② If an EEPROM module is not installed and processor memory is valid, the processor's PROC LED indicator blinks, and the processor sets S:11/9, bit 9 in the major fault status word. To clear this fault, change the processor from program mode to run mode and back to program mode.
- ③ If the processor's keyswitch is set in REMote, the processor enters remote RUN after it powers up and has its memory updated by the EEPROM module.
- ④ A processor fault (solid red PROC LED) occurs if processor memory is not valid.
- ⑤ You cannot clear processor memory when this switch is on.

2 Set the power supply configuration jumper.

3 Install the keying bands.

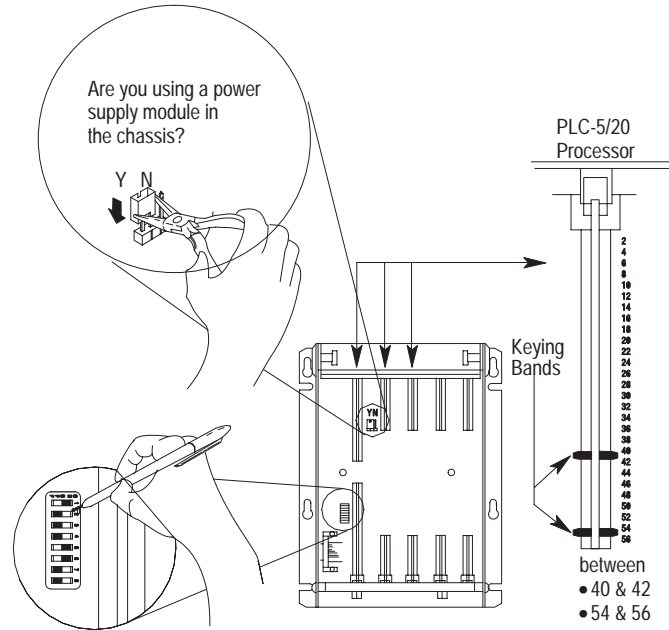

20609-M



For more information, see the Universal I/O Chassis installation instructions, publication number 1771-2.10.

Ground the I/O Chassis

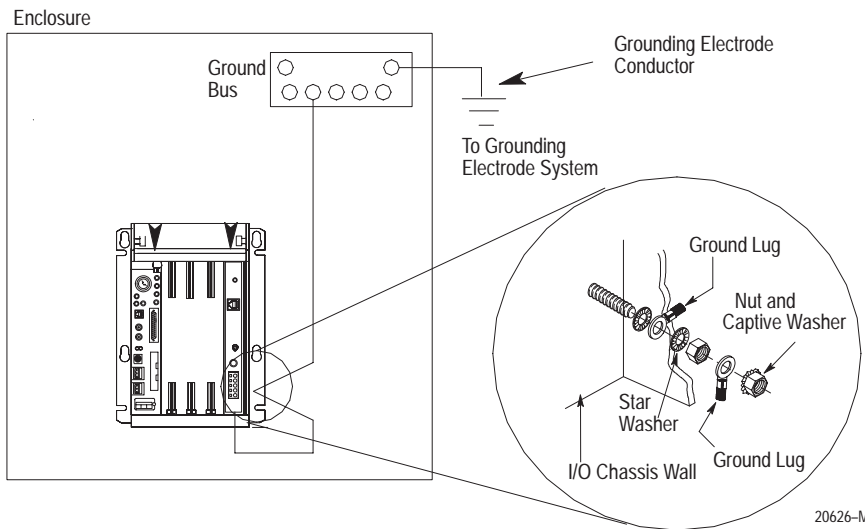

20626-M



For more information, see the Allen-Bradley Programmable Controller Wiring and Grounding Guidelines, publication number 1770-4.1.

Install the Power Supply

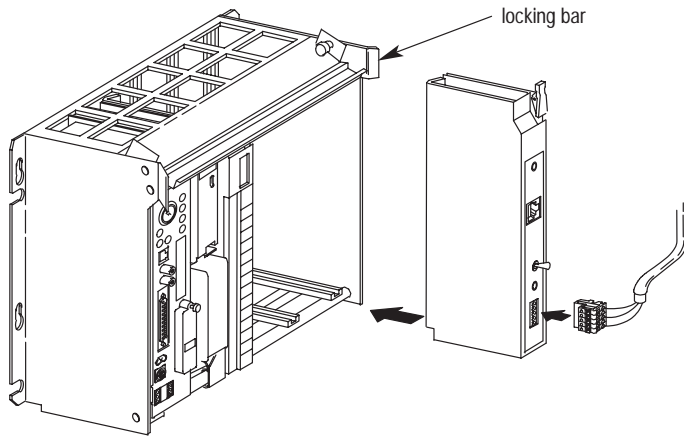

20619-M

1 Set the jumpers on the back side of the power supply like this:

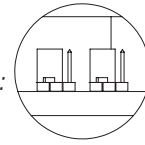

2 Connect the power cord to the 120V ac connector of the power supply module.

This side plugs into connector on the module.

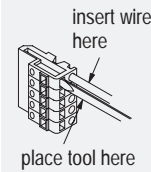

or

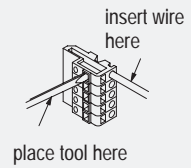

3 Install the power supply in the chassis and snap the module-locking bar over the modules.



For more information, see the Power Supply Modules (1771-P4S, -P6S, -P4S1, -P6S1) Installation Instructions, publication number 1771-2.135.

Install the PLC-5 Processor

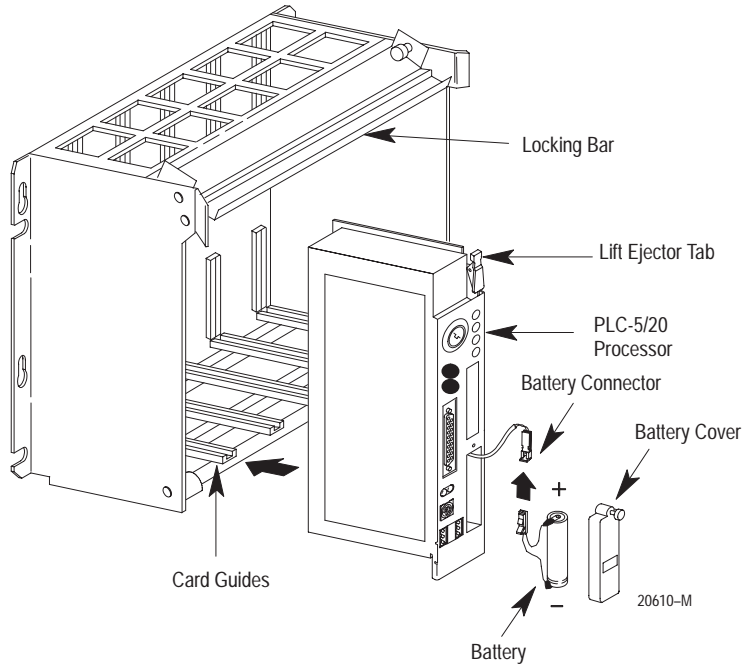

For detailed information about handling and disposing of the battery as well as other important guidelines, see publication AG-5.4.



For more information, see the ControlNet PLC-5 Programmable Controllers User Manual, publication number 1785-6.5.14.

1 Define the DH+ Station Address of Channel 1A by setting switch assembly SW-1 on the back of the processor. (See the side of the processor if you want to use another address.)

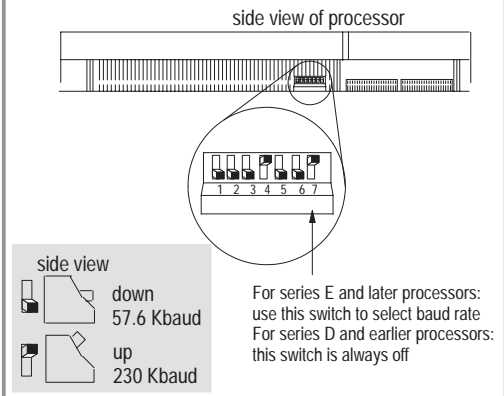

2 Specify the serial port configuration for channel 0.

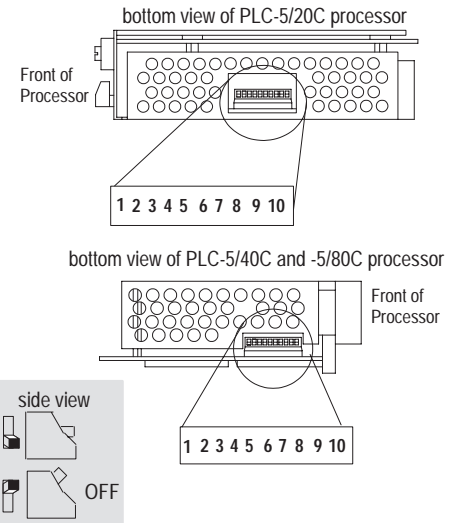

3 Set the ControlNet network addresses by using the two 10-digit rotary switches on top of the module.

ControlNet PLC-5 processor's NET address = 1

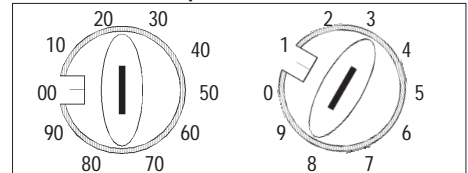

4 To install the battery, slide the battery-side connector into the processor-side connector until you hear them snap together, and attach the battery cover.

5 Install the processor module.

Powerup the System

Powerup the system. Check the LED display on the processor. If your system is operating properly, the PROC LED should be steady red. If the PROC LED is not red, see chapter 4 for troubleshooting information before you install any I/O modules.

Install the I/O Modules

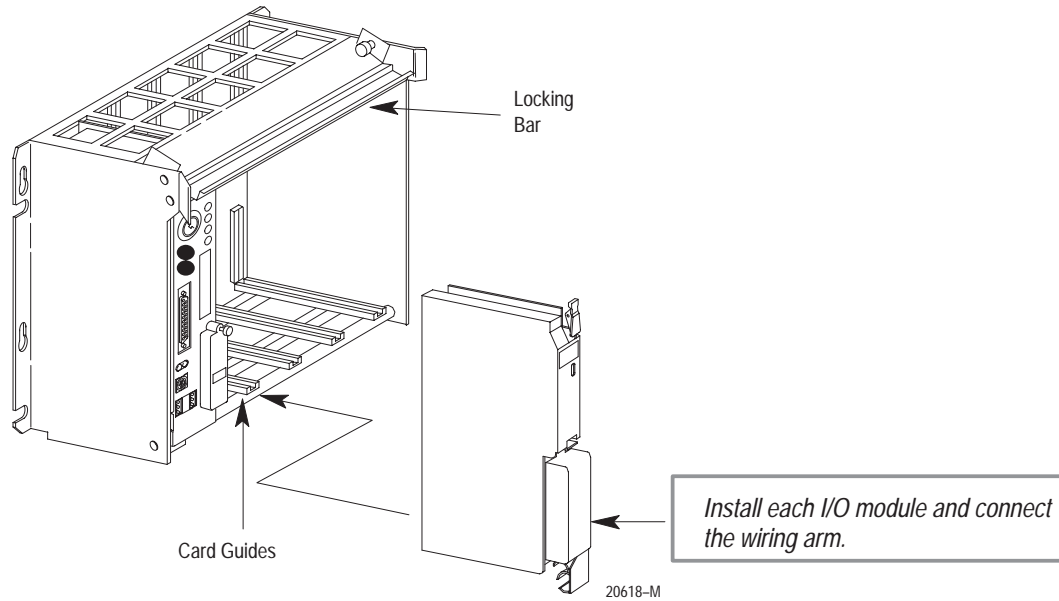

Connect the Personal Computer to the PLC-5 Processor



For more information, see the installation instructions or user manual for the particular module you are installing.



For more information, see:

- ControlNet PLC-5 Programmable Controllers User Manual, publication number 1785-6.5.14
- the documentation provided with your communication card
- Data Highway/Data Highway Plus/Data Highway II/Data Highway 485 Cable Installation Manual, publication 1770-6.2.2

Set Up the Software

Use 6200 programming software to configure your ControlNet system, including:

- defining network parameters (i.e. network update time, media redundancy usage, physical media configuration, maximum scheduled node, maximum unscheduled node)
- entering the channel 2 configuration

Install the Software and Set Up the Programming System

Before you install your programming software, make certain you meet the requirements for that software. Then, follow the procedures outlined in the online help and documentation to install the software and configure communication.

Start the Programming Software

Start the programming software by following the procedures described in your programming software documentation.

If you have difficulty, verify that the power supply is turned on.

To monitor your system as you configure and run it, check the processor LED display for the following indicators:

This LED:	lights when:
COMM	you establish communication, if connected via the serial port
BAT	no battery is installed or the battery voltage is low
FORCE	forces are present in your ladder program

Power Up the System

Power up the system if you have not done so already. Check the LED display on the processor. If you are using NAP cable, then the ControlNet LEDs will flash red. If you are using coaxial trunk cable, with taps and terminators, then the ControlNet channels that are connected will be steady green, and those that are unconnected will flash red.

Notes:

Troubleshoot the Processor System

Using This Chapter

If you want to read about:	See page:
Using the general status indicators	4-1
Using the ControlNet status indicators	4-3
Monitoring the ControlNet configuration and status screens	4-6

Using the General Status Indicators

The general status indicators inform you of the general operational state of the processor.

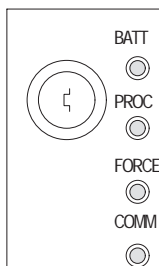

Indicator	Color	Description	Probable Cause	Recommended Action
BATT	Red	Battery low	Battery low	Replace battery within 10 days
	Off	Battery is good	Normal operation	No action required
PROC	Green (steady)	Processor is in run mode and fully operational	Normal operation	No action required
	Green (blinking)	Processor memory is being transferred to EEPROM		
	Red (blinking)	Major fault	Run-time error	<ul style="list-style-type: none"> Check major fault bit in status file (S:11) for error definition Clear fault bit, correct problem, and return to run mode
	Alternating Red and Green	Processor in FLASH-memory programming mode	Normal operation if processor's FLASH memory is being reprogrammed	No action required – allow flash update to complete
			Processor FLASH memory checksum error	Contact your local A-B representative for a field firmware update
	Red (steady)	Major fault	<ul style="list-style-type: none"> Processor memory has checksum error Memory module error Internal diagnostics have failed 	<ul style="list-style-type: none"> Clear memory and reload program Check backplane switch settings and/or insert correct memory module Power down, reseal processor and power up; then, clear memory and reload your program. Replace EEPROM with new program; then, if necessary, replace the processor
Off	Processor is in program load or test mode or is not receiving power		Check power supply and connections	



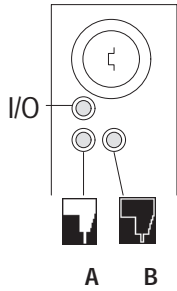

Indicator	Color	Description	Probable Cause	Recommended Action
FORCE	Amber (steady)	SFC and/or I/O forces enabled	Normal operation	No action required
	Amber (blinking)	SFC and/or I/O forces present but not enabled		
	Off	SFC and/or I/O forces not present		
COMM	Off	No transmission on channel 0	Normal operation if channel is not being used	
	Green (blinking)	Transmission on channel 0	Normal operation if channel is being used	

Using the ControlNet Status Indicators

The ControlNet status indicators inform you of the operational state of the ControlNet network.



Indicator	Color	Description	Probable Cause	Recommended Action
I/O	Off	ControlNet I/O not present or not operating	Normal operation if Channel 2 not being used	No action required
	Steady Green	All nodes configured in the ControlNet map table present and operating properly	Normal operation	No action required
	Flashing Green/Off	At least one node configured for the ControlNet network not present or not operating properly	Cable(s) or connector(s) broken or not connected	Repair or replace cable(s) or connector(s), and reconnect
			Destination module(s) bad or missing	Repair or replace module(s)
			Node(s) not on network	Connect node to network
	Flashing Red/Off	All nodes configured for ControlNet not present or not operating properly	Cable(s) or connector(s) broken or not connected	Repair or replace cable(s) or connector(s), and reconnect
Nodes not on network			Connect nodes to network	

Indicator	Color ^①	Probable Cause	Recommended Action	
 and  A B	Off	Internal diagnostics failed	1. Turn power off, make sure ControlNet address is not 00, reseal processor, then power up 2. Clear memory and reload your program 3. Replace EEPROM with new program 4. If still an error, replace the processor	
		No power	Check power supply	
	Steady Red	Faulted unit	Cycle power or reset unit	
			If fault persists, contact your Allen-Bradley Company, Inc. representative or distributor	
Alternating Red/Green	Self-test	No action required		
Alternating Red/Off	Incorrect node configuration	Check network address and other ControlNet configuration parameters		
 or  A B	Off	Channel disabled	No action required Configure for ControlNet communication	
		Steady Green	Normal operation	No action required
	Flashing Green/Off	Temporary errors	No action required	
			The processor's ControlNet address is above UMAX	Configure the ControlNet network so that UMAX is at least as high as the processor's ControlNet address.
				Set the processor's ControlNet address at or below UMAX.
	Flashing Red/Off	Media fault	Check media for broken cables, loose connectors, missing terminators, etc.	
		No other nodes present on network	Add other nodes to the network	
	Flashing Red/Green	Incorrect network configuration	Cycle power or reset unit	
If fault persists, contact your Allen-Bradley Company, Inc. representative or distributor				

^① Definition of terms:

- **alternating**—the two indicators alternate between the two defined states at the same time (applies to both indicators *viewed together*); the two indicators are always in opposite states, out of phase
- **flashing**—the indicator alternates between the two defined states (applies to each indicator *viewed independent* of the other); if both indicators are flashing, they flash together, in phase
- **steady**—indicator is on continuously in the defined state

Using the DH+/RIO Status Indicators

Indicator	Color	Channel Mode	Description	Probable Cause	Recommended Action
A or B	Green (steady)	Remote I/O Scanner	Active Remote I/O link, all adapter modules are present and not faulted	Normal operation	No action required
		Remote I/O Adapter	Communicating with scanner		
		DH+	Processor is transmitting or receiving on DH+ link		
	Green (blinking rapidly or slowly)	Remote I/O Scanner	At least one adapter is faulted or has failed	<ul style="list-style-type: none"> Power off at remote rack Cable broken 	<ul style="list-style-type: none"> Restore power to the rack Repair cable
		DH+	No other nodes on network		
	Red (steady)	Remote I/O Scanner Remote I/O Adapter DH+	Hardware fault	Hardware error	<ul style="list-style-type: none"> Turn power off, then on. Check that the software configurations match the hardware set-up. Replace the processor.
	Red (blinking rapidly or slowly)	Remote I/O Scanner	Faulted adapters detected	<ul style="list-style-type: none"> Cable not connected or is broken Power off at remote racks 	<ul style="list-style-type: none"> Repair cable Restore power to racks
		DH+	Bad communication on DH+		
	Off	Remote I/O Scanner Remote I/O Adapter DH+	Channel offline	Channel is not being used	Place channel online if needed

Monitoring ControlNet Configuration and Status

Use 6200 programming software to monitor ControlNet configuration and status information, including:

- ControlNet configuration
- map entry status
- I/O action
- network and node status



For information about using 6200 programming software or RSLogix5 software, see the online help systems or contact your local Allen-Bradley representative.

Processor Specifications





Backplane Current (3 Amps @ 5V dc)	PLC-5/20C: 2.7A PLC-5/40C, -5/60C, -5/80C: 3.3A
Heat Dissipation	PLC-5/20C: 54 BTU/hour PLC-5/40C, -5/80C: 59 BTU/hour
Environmental Conditions	Operating Temperature: 0 to 60° C (32-140° F) Storage Temperature: -40 to 85° C (-40 to 185° F) Relative Humidity: 5 to 95% (without condensation)
Shock	Operating 30 g peak acceleration for 11±1 ms duration Non-operating 50 g peak acceleration for 11±1 ms duration
Vibration	1 g @ 10 to 500 Hz 0.012 inches peak-to-peak displacement
Time-of-Day Clock/Calendar^①	Maximum Variations at 60° C: ± 5 min per month Typical Variations at 20° C: ± 20 s per month Timing Accuracy: 1 program scan
Battery	1770-XYC
Memory Modules	<ul style="list-style-type: none"> • 1785-ME16 • 1785-ME32 • 1785-ME64 • 1785-M100
I/O Modules	Bulletin 1771 I/O, 1794 I/O, 1746 I/O, and 1791 I/O including 8-, 16-, 32-pt, and intelligent modules
Hardware Addressing	2-slot <ul style="list-style-type: none"> • Any mix of 8-pt modules • 16-pt modules must be I/O pairs • No 32-pt modules 1-slot <ul style="list-style-type: none"> • Any mix of 8- or 16-pt modules • 32-pt modules must be I/O pairs 1/2-slot—Any mix of 8-, 16-, or 32-pt modules
Communication	<ul style="list-style-type: none"> • Serial • DH+ • DH using 1785-KA • Remote I/O • ControlNet
Location	1771-A1B, -A2B, A3B, -A3B1, -A4B chassis; left-most slot
Weight	PLC-5/20C: 3 lbs, 3 oz (1.45 kg) PLC-5/40C: 3 lbs, 2 oz (1.42 kg) PLC-5/60C, -5/80C: 3 lbs, 2 oz (1.42 kg)
Keying	<ul style="list-style-type: none"> • Between 40 and 42 • Between 54 and 56
Agency Certification (When product or packaging is marked)	<ul style="list-style-type: none"> • CSA certified • CSA Class I, Division 2 Groups A, B, C, D certified • UL listed • CE marked for all applicable directives
^① The clock/calendar will update appropriately each year, including the year 2000.	

		PLC-5/20C	PLC-5/40C	PLC-5/60C	PLC-5/80C
Maximum User Memory Words		16K	48K ^①	100K ^②	100K ^③
Maximum Total I/O	Any Mix	512	2048	3072	3072
	Complimentary	512 in and 512 out	2048 in and 2048 out	3072 in and 3072 out	3072 in and 3072 out
Program Scan Time		0.5 ms per K word (bit logic) 2 ms per K word (typical)			
ControlNet I/O^③	Transmission Rate	5M bit/s			
	Network Update Time (NUT)	2-100 ms (user selectable)			
	Number of ControlNet Ports	1 (redundant)			
	Maximum Number of Nodes per Link without a Repeater	48—with 250 m (approx. 820 ft) cable length			
	Maximum Number of Nodes per Link with Repeaters	107			
	Maximum Link Cable Length without a Repeater	1,000 m (approximately 3,280 ft)—with 2 nodes 500 m (approximately 1,640 ft)—with 32 nodes 250 m (approximately 820 ft)—with 48 nodes			
	Maximum DIF/DOF Size	1000 words in and 1000 words out			
	Maximum Link Cable Length with Repeaters	6,000 m (approximately 19,680 ft)—with 2 nodes 3,000 m (approximately 9,840 ft)—typical			
Remote I/O and DH+	Transmission Rate	57.6K bit/s 115.2K bit/s 230.4K bit/s			
	I/O Scan Time (Typical)	10 ms per rack @ 57.6K bit/s 7 ms per rack @ 115.2K bit/s 3 ms per rack @ 230K bit/s			
	Maximum Number of Remote I/O Racks	3	15	23	23
	Maximum Number of Remote I/O Devices	12	60	92	92
	Number of Ports Configurable for DH+ or Remote I/O (Adapter or Scanner)	1	2	2	2
	Number of Dedicated DH+ Ports	1	0	0	0
Number of Serial Ports		1			
Number of Coprocessor Ports		1			
Maximum Number of MCPs		16			

^① The PLC-5/40C processor has a limit of 32K words per data-table file.

^② The PLC-5/60C processor has a limit of 56K words per program file and 32 K words per data table file.

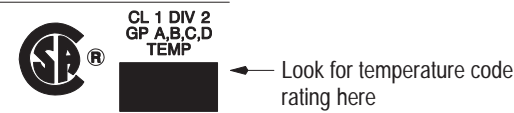
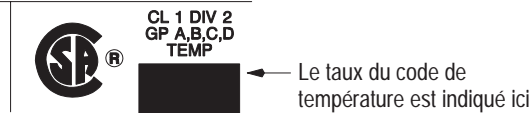
^③ The PLC-5/80C processor has a limit of 56K words per program file and 32 K words per data table file. The PLC-5/80C processor has 64K words of total data table space.

CSA Hazardous Location Approval	Approbation d'utilisation dans des emplacements dangereux par la CSA
<p>CSA certifies products for general use as well as for use in hazardous locations. Actual CSA certification is indicated by the product label as shown below, and not by statements in any user documentation.</p>	<p>La CSA certifie les produits d'utilisation générale aussi bien que ceux qui s'utilisent dans des emplacements dangereux. La certification CSA en vigueur est indiquée par l'étiquette du produit et non par des affirmations dans la documentation à l'usage des utilisateurs.</p>
<p>Example of the CSA certification product label</p> 	<p>Exemple d'étiquette de certification d'un produit par la CSA</p> 
<p>To comply with CSA certification for use in hazardous locations, the following information becomes a part of the product literature for CSA-certified Allen-Bradley industrial control products.</p> <ul style="list-style-type: none"> • This equipment is suitable for use in Class I, Division 2, Groups A, B, C, D, or non-hazardous locations only. • The products having the appropriate CSA markings (that is, Class I Division 2, Groups A, B, C, D), are certified for use in other equipment where the suitability of combination (that is, application or use) is determined by the CSA or the local inspection office having jurisdiction. 	<p>Pour satisfaire à la certification de la CSA dans des endroits dangereux, les informations suivantes font partie intégrante de la documentation des produits industriels de contrôle Allen-Bradley certifiés par la CSA.</p> <ul style="list-style-type: none"> • Cet équipement convient à l'utilisation dans des emplacements de Classe 1, Division 2, Groupes A, B, C, D, ou ne convient qu'à l'utilisation dans des endroits non dangereux. • Les produits portant le marquage approprié de la CSA (c'est à dire, Classe 1, Division 2, Groupes A, B, C, D) sont certifiés à l'utilisation pour d'autres équipements où la convenance de combinaison (application ou utilisation) est déterminée par la CSA ou le bureau local d'inspection qualifié.
<p>Important: Due to the modular nature of a PLC control system, the product with the highest temperature rating determines the overall temperature code rating of a PLC control system in a Class I, Division 2 location. The temperature code rating is marked on the product label as shown.</p>	<p>Important: Par suite de la nature modulaire du système de contrôle PLC, le produit ayant le taux le plus élevé de température détermine le taux d'ensemble du code de température du système de contrôle d'un PLC dans un emplacement de Classe 1, Division 2. Le taux du code de température est indiqué sur l'étiquette du produit.</p>
<p>Temperature code rating</p> 	<p>Taux du code de température</p> 
<p>The following warnings apply to products having CSA certification for use in hazardous locations.</p>	<p>Les avertissements suivants s'appliquent aux produits ayant la certification CSA pour leur utilisation dans des emplacements dangereux.</p>
 <p>ATTENTION: Explosion hazard —</p> <ul style="list-style-type: none"> • Substitution of components may impair suitability for Class I, Division 2. • Do not replace components unless power has been switched off or the area is known to be non-hazardous. • Do not disconnect equipment unless power has been switched off or the area is known to be non-hazardous. • Do not disconnect connectors unless power has been switched off or the area is known to be non-hazardous. Secure any user-supplied connectors that mate to external circuits on an Allen-Bradley product using screws, sliding latches, threaded connectors, or other means such that any connection can withstand a 15 Newton (3.4 lb.) separating force applied for a minimum of one minute. • Batteries must only be changed in an area known to be non-hazardous. 	 <p>AVERTISSEMENT: Risque d'explosion —</p> <ul style="list-style-type: none"> • La substitution de composants peut rendre ce matériel inacceptable pour les emplacements de Classe I, Division 2. • Couper le courant ou s'assurer que l'emplacement est désigné non dangereux avant de remplacer les composants. • Avant de débrancher l'équipement, couper le courant ou s'assurer que l'emplacement est désigné non dangereux. • Avant de débrancher les connecteurs, couper le courant ou s'assurer que l'emplacement est reconnu non dangereux. Attacher tous connecteurs fournis par l'utilisateur et reliés aux circuits externes d'un appareil Allen-Bradley à l'aide de vis, loquets coulissants, connecteurs filetés ou autres moyens permettant aux connexions de résister à une force de séparation de 15 newtons (3,4 lb. - 1,5 kg) appliquée pendant au moins une minute. • S'assurer que l'environnement est classé non dangereux avant de changer les piles.

Notes



Allen-Bradley Publication Problem Report

If you find a problem with our documentation, please complete and return this form.

Pub. Name ControlNet PLC-5 Programmable Controllers Quick Start, Phase 1.25

Cat. No. 1785-L20C, -40C, -60C, -80C

Pub. No. 1785-10.7

Pub. Date October 1997

Part No. 955129-12

Check Problem(s) Type:	Describe Problem(s):	Internal Use Only
<input type="checkbox"/> Technical Accuracy	<input type="checkbox"/> text <input type="checkbox"/> illustration	
<input type="checkbox"/> Completeness What information is missing?	<input type="checkbox"/> procedure/step <input type="checkbox"/> illustration <input type="checkbox"/> definition <input type="checkbox"/> example <input type="checkbox"/> guideline <input type="checkbox"/> feature <input type="checkbox"/> explanation <input type="checkbox"/> other	<input type="checkbox"/> info in manual (accessibility) <input type="checkbox"/> info not in manual
<input type="checkbox"/> Clarity What is unclear?		
<input type="checkbox"/> Sequence What is not in the right order?		
<input type="checkbox"/> Other Comments Use back for more comments.		

Your Name _____ Location/Phone _____

Return to: Technical Communication, Allen-Bradley Co., 1 Allen-Bradley Drive, Mayfield Hts., OH 44124

Phone: (216)646-3166

FAX: (216)646-4320

PLEASE FASTEN HERE (DO NOT STAPLE)

Other Comments

Lined area for writing comments.

PLEASE FOLD HERE



NO POSTAGE
NECESSARY
IF MAILED
IN THE
UNITED STATES

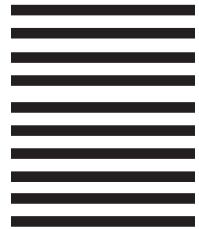

PLEASE REMOVE

BUSINESS REPLY MAIL
FIRST-CLASS MAIL PERMIT NO. 18235 CLEVELAND OH

POSTAGE WILL BE PAID BY THE ADDRESSEE



Allen-Bradley

1 ALLEN BRADLEY DR
MAYFIELD HEIGHTS OH 44124-9705





Allen-Bradley, a Rockwell Automation Business, has been helping its customers improve productivity and quality for more than 90 years. We design, manufacture and support a broad range of automation products worldwide. They include logic processors, power and motion control devices, operator interfaces, sensors and a variety of software. Rockwell is one of the world's leading technology companies.



Worldwide representation.

Argentina • Australia • Austria • Bahrain • Belgium • Brazil • Bulgaria • Canada • Chile • China, PRC • Colombia • Costa Rica • Croatia • Cyprus • Czech Republic • Denmark • Ecuador • Egypt • El Salvador • Finland • France • Germany • Greece • Guatemala • Honduras • Hong Kong • Hungary • Iceland • India • Indonesia • Ireland • Israel • Italy • Jamaica • Japan • Jordan • Korea • Kuwait • Lebanon • Malaysia • Mexico • Netherlands • New Zealand • Norway • Pakistan • Peru • Philippines • Poland • Portugal • Puerto Rico • Qatar • Romania • Russia-CIS • Saudi Arabia • Singapore • Slovakia • Slovenia • South Africa, Republic • Spain • Sweden • Switzerland • Taiwan • Thailand • Turkey • United Arab Emirates • United Kingdom • United States • Uruguay • Venezuela • Yugoslavia

Allen-Bradley Headquarters, 1201 South Second Street, Milwaukee, WI 53204 USA, Tel: (1) 414 382-2000 Fax: (1) 414 382-4444