



Low voltage AC drives

ABB industrial drives ACS880, multidrives 1.5 to 7500 hp (1.5 to 5600 kW) Catalog

Power and productivity
for a better world™



What does all-compatible mean for you?

Being all-compatible means that drive choice should add value to your business. Drives should meet the unique demands of your processes, help you save energy and reduce operating costs. Also, all-compatible means that our drives are easy to select, use and maintain. These are the cornerstones making our industrial drive series the all-compatible choice.

Contents

3	The all-compatible ACS880 series drives
4	Simplifying your world without limiting your possibilities
5	Multidrives, ACS880
6	Human all-compatible
7	Process all-compatible
8	Environment all-compatible
9	Business all-compatible
10	How to select a drive
11	Technical data
12	ACS880 multidrives
13	Overview of the construction
14-15	Ratings, types and voltages, 500 V - Inverter modules (INU), ACS880-107, IGBT supply units (ISU), ACS880-207, Regenerative rectifier units (RRU), ACS880-907, Diode supply modules (DSU), ACS880-307
16-17	Ratings, types and voltages, 690 V - Inverter modules (INU), ACS880-107, IGBT supply units (ISU), ACS880-207, Regenerative rectifier units (RRU), ACS880-907, Diode supply modules (DSU), ACS880-307
18	Standard interface and extensions for comprehensive connectivity
19	Standard software for scalable control and functionality
20	Intuitive human-machine interface
21	PC tool for easy startup and maintenance
22	Designed to control virtually any type of motor
23	Integrated safety for simplified configuration
24	Drive application programming based on IEC standard 61131-3
25	Application control programs
26	Flexible connectivity to automation networks
27	Input/output extension modules for increased connectivity
27	Speed feedback interfaces for precise process control
27	I/O option extension adapter
27	DDCS communication option modules
28	Remote monitoring access worldwide
28	EMC – electromagnetic compatibility
29	Sine filters
30-31	Brake options, ACS880-607
31	Dimensioning tool for selecting the optimal drive
32-33	Summary of features and options
34	Expertise at every stage of the value chain
35	Secure uptime throughout the drive life cycle

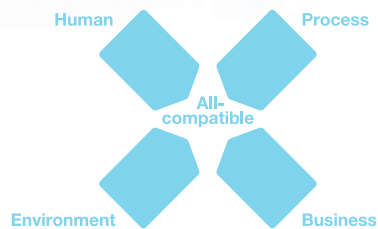

The all-compatible ACS880 series drives

The ACS880 series drives are part of ABB's all-compatible drives portfolio. Compatible with virtually all types of processes, automation systems, users and business requirements they are designed to tackle any motor-driven application, in any industry, whatever the power range. The innovation behind all-compatibility is our new drives architecture that simplifies operation, optimizes energy efficiency and helps maximize process output. The ACS880 series consists of single drives, multidrives and drive modules.

Simplifying your world without limiting your possibilities

Wide range of safety features

Safe torque off is built-in as standard. An optional safety functions module provides extended safety functions, simplifying the configuration and reducing installation space.



Direct torque control (DTC)

ABB's signature motor control technology provides precise speed and torque control for all applications and virtually any type of AC motor.



Application control programs

A range of ready-made programs to optimize application productivity and usability.

Removable memory unit

Stores all the software and parameter configurations in an easily replaceable and simple-to-install module.



Energy efficiency

The drive provides features such as an energy optimizer and energy efficiency information that help you monitor and save the energy used in the processes.



Remote monitoring

With a built-in web server, NETA-21 makes worldwide access easy to industry applications.

Drive-to-drive link

Allows fast communication between drives including master-follower configurations without any additional hardware.

Drive application programming

Customizable to meet the precise application needs based on IEC 61131-3. The drive is also easy to integrate with other ABB components such as PLC and HMI.



Multidrives, ACS880

The all-compatible drives are designed to provide customers across several industries and applications with unprecedented levels of compatibility and flexibility. The ACS880 multidrives are customized meet the precise needs of industries such as metals, pulp and paper, oil and gas, mining, harbours, offshore, marine and power plants. They control a wide range of applications such as paper machines, winders, rolling mills, processing lines, roller tables, cranes and drilling.



Intuitive human-machine interface

Intuitive, high-contrast and high-resolution display enabling easy navigation in multiple languages.



Startup and maintenance tool

PC tool for drive startup, configuration and daily use and process tuning. PC tool is connected to the drive via Ethernet or USB interface.



Communication with all major automation networks

Fieldbus adapters enable connectivity with all major automation networks.



Extended connectivity

In addition to the standard interfaces, the drive has three built-in slots for additional input/output extension modules and speed feedback interfaces.

Flexible product configurations

Drives are built to order with a wide range of options such as braking options and different enclosure variants.



Human all-compatible

The new drives share easy-to-use interfaces saving you time during drive commissioning and maintenance. When you have learned it once, you can use it with all the drives in our all-compatible drives portfolio.

The new control panel supports over 20 languages. The new PC tool provides extensive drive monitoring capabilities and quick access to the drive settings. Integrated and certified safety features provide safety for machine operators.





Process all-compatible

The drives are compatible with all kinds of processes. They control virtually any type of AC motor, provide extensive input/output connectivity and support all major fieldbus protocols. The drives cover a wide voltage and power range. Control performance is scalable from basic to demanding applications delivered by direct torque control (DTC). The flexibility and scalability of the drives enable one drive platform to control virtually any application or process, making your drive selection easy.



Environment all-compatible



There is an increased demand for reducing industries' impact on the environment. Our drives can help you reduce energy consumption in a wide range of applications. The new drives have an energy optimizer feature that ensures maximum torque per ampere, reducing energy drawn from the supply. The built-in energy efficiency calculators help you to analyze and optimize processes. We can help you to investigate the energy saving potential of selected applications with our six-step energy appraisal. Our services expand through the life cycle of the drive and help you maintain energy efficiency from installation and commissioning to drive replacement.





Business all-compatible

The new all-compatible drives are not just equipment but part of your business strategy. Providing better control over your processes, the new drives equal lower energy consumption, improved productivity, flexibility and ease of use. In addition to drives we offer a wide range of products and services to support your business. With offices in over 90 countries and a global technical partner network, we are in a good position to offer technical advice and local support, worldwide.

How to select a drive

Many of the features for the ACS880 multidrives are built-in as standard, making selection easy. A wide range of options are available to optimize the drive for different requirements. To choose the right drive for your application, please refer to the rating tables within this catalog or use ABB's DriveSize dimensioning tool. The selected drive has a unique type

designation, which identifies the drive by construction, power and voltage range. The options are added to the type designation with a "plus" code. Build up your own ordering code using the type designation key or contact your local ABB drives sales office and let them know your needs/requirements.



Technical data

Type designation:

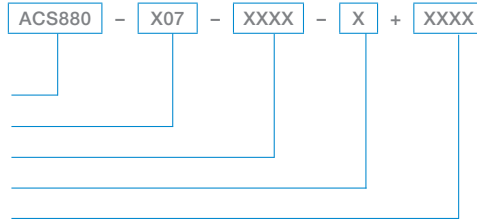

Mains connection

Voltage and power range	3-phase, $U_{N3} = 380$ to 415 V, +10/-10% 3-phase, $U_{N5} = 380$ to 500 V, +10/-10% 3-phase, $U_{N7} = 525$ to 690 V, +10/-10% 1.5 to 7500 hp (1.5 to 5600 kW) Inverter units (INU) 1.5 to 5600 kW IGBT supply unit (ISU) 300 to 6100 kVA Diode supply unit (DSU) 50 to 5500 kVA Regenerative rectifier unit (RRU) 400 to 6100 kVA
Frequency	50/60 Hz $\pm 5\%$
Power factor	IGBT supply unit (ISU): $\cos\phi = 1$ (fundamental) $\cos\phi = 0.99$ (total) Diode supply unit (DSU): $\cos\phi = 0.98$ (fundamental) $\cos\phi = 0.93$ to 0.95 (total)
THD (total harmonic distortion of current) ISU	< 5%
Efficiency (at nominal power)	98% with DSU and RRU 97.5% with ISU

Motor connection

Voltage	3-phase output voltage 0 to $U_{N3} / U_{N5} / U_{N7}$
Frequency	0 to ± 500 Hz ^{1) 4)}
Motor control	Direct torque control (DTC)
Torque control:	Torque step rise time: Open loop <5 ms with nominal torque Closed loop <5 ms with nominal torque Non-linearity: Open loop $\pm 4\%$ with nominal torque Closed loop $\pm 3\%$ with nominal torque
Speed control:	Static accuracy: Open loop 10% of motor slip Closed loop 0.01% of nominal speed Dynamic accuracy: Open loop 0.3 to 0.4% seconds with 100% torque step Closed loop 0.1 to 0.2% seconds with 100% torque step

Product compliance

- CE
- Low Voltage Directive 2006/95/EC
- Machinery Directive 2006/42/EC
- EMC Directive 2004/108/EC
- Quality assurance system ISO 9001 and Environmental system ISO 14001
- RoHS
- UL, EAC/GOST R ³⁾, cUL 508A or cUL 508C, CSA, C-Tick.
- Functional safety: STO TÜV Nord certificate

EMC according to EN 61800-3 (2004)

2nd environment, unrestricted distribution category C3, as option

Environmental limits

Ambient temperature	Transport -40 to 158 °F (-40 to 70 °C) Storage -40 to 158 °F (-40 to 70 °C) Operation (air-cooled) 32 to 122 °F (0 to 50 °C), no frost allowed 104 to 122 °F (40 to 50 °C) with derating of 1%/1.8 °F (1%/1 °C)
Cooling method	Air-cooled Dry clean air
Altitude	0 to 3300 ft (1 to 1000 m) 3,300 to 13,333 ft (1,000 to 4,000 m) Without derating With derating of 1%/330 ft (1%/100 m)
Relative humidity	5 to 95%, no condensation allowed
Degree of protection	IP22 Standard (IP20 cabinet doors open) IP42, IP54 Option
Paint color	RAL 9017, RAL 7035
Contamination levels	No conductive dust allowed
Storage	IEC 60721-3-1, Class 1C2 (chemical gases), Class 1S2 (solid particles)
Transportation	IEC 60721-3-2, Class 2C2 (chemical gases), Class 2S2 (solid particles)
Operation	IEC 60721-3-3, Class 3C2 (chemical gases), Class 3S2 (solid particles)
Vibration	IEC 60068-2-6, 10 to 58 Hz 0.075 mm displacement amplitude 58 to 150 Hz 10m/s ²
Functional safety	Standard Safe torque off (STO according EN/IEC 61800-5-2) IEC 61508 ed2: SIL 3, IEC 61511: SIL 3, EN/IEC 62061: SIL CL 3, EN ISO 13849-1: PL e TÜV Nord certified ²⁾ Safety functions are implemented in the multidrives with the FSO-12

C = Chemically active substances

S = Mechanically active substances

¹⁾ Operation above 150 Hz might require type specific derating, please contact your local ABB office

²⁾ Please check availability per drive type

³⁾ EAC will replace GOST R

⁴⁾ For higher operational output frequencies please contact your local ABB office

ACS880 multidrives

Our ACS880 multidrives are built using ABB's common drives architecture. Built to order, the multidrives meet technical challenges through a wide selection of options that are mountable within the cabinet. With a compact cabinet design and high power density, the single supply and DC bus arrangement with multiple inverters will reduce line power, cabinet size and investment costs.

Induction motors, permanent magnet synchronous motors, synchronous reluctance motors and induction servo motors are all supported as standard without the need for any additional software. The drive can control the motors in either open loop or closed loop through its high precision motor control platform, direct torque control (DTC). Built-in safety features reduce the need for external safety components.

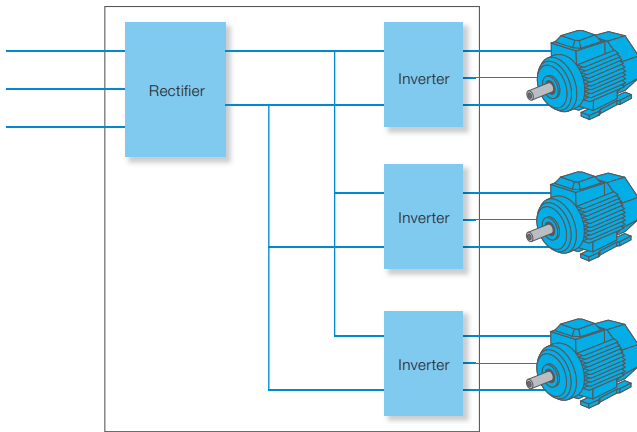

Main features include

- Compact design for easy cabinet assembly and maintenance
- High packing density with 16 inverter units up to frame size R2i can be installed into one cabinet
- Diode bridge that is highly reliable with high power density
- Fast connectors for motor cables in the bottom part of the cabinet making installation easy
- Degree of protection IP22, IP42 and IP54 for different environments
- Integrated safety including safe torque off (STO) as standard with several safety functions as options
- Drive composer PC tool for commissioning and configuration
- Intuitive control panel with USB connection
- Device panel for optional switches and pilot light
- Primary control program – common software used throughout the ACS880 drive series
- Control unit ZCU for inverters (R1i to R7i) and diode supply unit (D6D to D8D) comes with three option slots for extension option modules
- Control unit BCU is used for ISU (IGBT supply unit) RRU and DSU (DXT) that comes with integrated branching unit, embedded Ethernet and three option slots with an additional slot for DDCS communication option
- Removable memory unit for easy maintenance
- Coated boards as standard
- Braking options
- Cabinet light and heater option
- Highly efficient thermal handling as heat loss of each inverter unit is guided to the back of the cabinet. All cabinets are their own compartments.
- Long lifetime capacitors and high efficiency cooling fan with speed or on-off control



IGBT supply unit (ISU) with 18 inverters

Overview of the construction

The multidrives principle is based on a common DC bus arrangement, enabling single power entry and common braking resources for several drives. There are several possibilities on the supply side starting from a simple diode supply unit up to highly sophisticated active IGBT supply units.

Multidrives can be used wherever several motors form part of a single process. They come with a common DC bus arrangement, enabling single power entry for several drives. The energy circulating over the common DC bus results in energy and cost savings, as not all energy is taken from the supply network allowing the supply unit in the drive to have smaller dimensions. A single power line connection and a common supply unit reduces the need for cabling and floor space, saving investment and maintenance costs. In multimotor applications, for example in a paper machine, the individual inverter modules provide fast communication of torque and speed signals between the inverters for controlling the tension in the paper web. Also in cases where the shafts of the individual motors are not tightly coupled, for example in sugar centrifuges, each inverter module can be programmed with a speed profile in order to minimize overall energy consumption. These two examples merely demonstrate the range of applications where multidrives offer substantial benefits over other types of drive constructions.

Constructed for controlling multiple motors

Multidrives are made up of several different units (see figure below). The most important units include:

- Drive units, known as inverter units (INU)
- Supply units
- Brake units (optional)
- Control units (optional)

The common supply of the multidrive enables the implementation of overall safety and control functions.

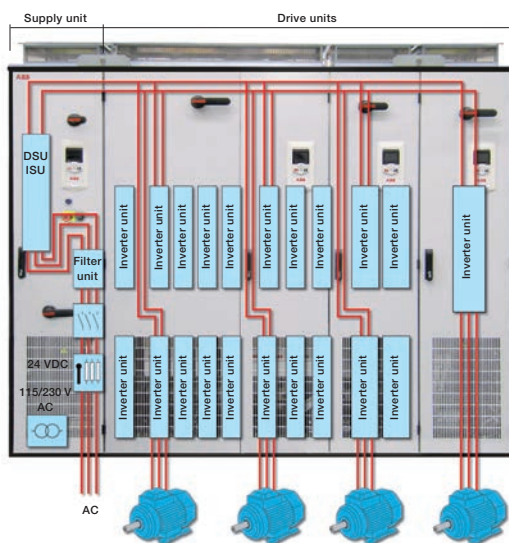

Inverter units (INU)

Inverter modules are available in 8 different frame sizes. Frame sizes R1i to n×R8i range from 1.5 to 5600 kW, and the voltage ranges from 380 to 690 V. Inverter units have built-in capacitors for smoothing the voltage of the DC busbars. The electrical connection to the common DC busbar is fuse protected. An individual inverter unit can be disconnected from the DC bus,

either by a fuse disconnecter or by a DC switch. Each inverter unit has safe torque off (STO) built-in as standard. Control units in use are ZCU for R1i to R7i and BCU for n×R8i. The control unit has three slots to place different option adapters on such as input/output extension modules, speed feedback modules and fieldbus adapter modules.

Diode supply unit (DSU)

A diode supply unit is used in non-regenerative drive systems to convert three-phase AC voltage to DC voltage. Multidrives have two types of diode supply units. One of these is the 6-pulse diode supply unit (D6D to D8D). This supply unit is available only in the limited scope for ACS880 multidrives with a power range from 60 to 850 kVA that has no charging circuit and is not parallel connected. The charging is built into the drive units (R1i to R4i and R6i to R7i). This diode supply unit is controlled by the ZCU control unit.

The other diode supply unit type (D7T and D8T) offers a power range from 340 to 5445 kVA, with 1 to 6 parallel modules. This diode supply module has thyristor charging, BCU control unit and 6-pulse and 12-pulse versions available.

IGBT supply unit (ISU)

An IGBT supply unit is used in regenerative drive systems to convert three-phase AC voltage to DC voltage. ISU is made of n×R8i inverter frames and LCL line filters for a power range from 300 to 6100 kVA. With power control, it gives the same firm but gentle performance as direct torque control (DTC) gives in motor control. The converter can operate in both motoring and generating modes.

The DC voltage is constant and the line current is sinusoidal. The control also provides a near unity power factor. The unit can also boost DC voltages eg, when line voltage is low. Harmonic content remains extremely low due to excellent control and LCL filtering. ISU is very tolerable to network voltage variations.

Regenerative rectifier unit (RRU)

This supply unit is used in regenerative drive systems to convert three-phase AC voltage to DC voltage. The RRU is made of n×R8i inverter units and L filters. The IGBTs' are switched conducting only once during each network voltage cycle. This reduces switching losses and enables higher powers of the same power module. Operation of RRU is also reliable during supply network voltage variations.

Brake unit

The brake unit handles the energy generated by decelerating motors. During resistor braking, whenever the voltage in the intermediate circuit of a drive exceeds a certain limit, a braking chopper connects the circuit to a braking resistor. Offering includes 1-phase brake unit and 3-phase dynamic brake unit (DBU) which utilizes R8i modules.

AC 800M control unit (optional)

The multidrive concept also includes the control unit for the AC800M process controller and S800 I/O system. The control unit is equipped with communication interfaces, power supplies and the front devices necessary for the automation equipment.

Ratings, types and voltages

Inverter units, $U_N = 500 \text{ V}$

Inverter unit (INU), ACS880-107

$U_N = 500 \text{ V}$ (range 380 to 500 V). The power ratings are valid at nominal voltage 500 V.

Light-overload use			Heavy-duty use			Noise level	Heat dissipation	Air flow	Type designation	Frame size
I_{Ld}	P_{Ld}		I_{Hd}	P_{Hd}						
A	hp	kW	A	hp	kW	dB(A)	kW	cfm		
3.4	1.5	1.5	3	1.5	1.5					
4.5	2	2.2	4	2	2.2	47	0.07	14	ACS880-107-004A8-5	R1i
5.5	3	3	5	3	2.2	47	0.08	14	ACS880-107-006A0-5	R1i
7.6	5	4	6	3	3	47	0.09	14	ACS880-107-008A0-5	R1i
9.7	5	5.5	9	5	4	39	0.13	28	ACS880-107-0011A-5	R2i
13	7.5	7.5	11	7.5	5.5	39	0.15	28	ACS880-107-0014A-5	R2i
16.8	10	7.5	14	10	7.5	39	0.18	28	ACS880-107-0018A-5	R2i
23	15	11	19	10	11	63	0.23	84	ACS880-107-0025A-5	R3i
28	20	15	24	15	15	63	0.28	84	ACS880-107-0030A-5	R3i
32	20	18.5	29	20	18.5	63	0.32	84	ACS880-107-0035A-5	R3i
46	30	30	44	30	30	71	0.48	118	ACS880-107-0050A-5	R3i
57	40	37	52	40	30	70	0.55	171	ACS880-107-0061A-5	R4i
74	50	45	69	50	45	70	0.65	171	ACS880-107-0078A-5	R4i
90	60	55	75	50	45	70	0.8	171	ACS880-107-0094A-5	R4i
108	75	75	85	60	55	71	1	318	ACS880-107-0110A-5	R6i
131	100	90	102	75	55	71	1.2	318	ACS880-107-0140A-5	R6i
158	125	110	123	100	75	71	1.5	318	ACS880-107-0170A-5	R6i
189	150	132	147	125	90	71	1.8	318	ACS880-107-0200A-5	R6i
230	200	160	180	150	110	71	2.2	318	ACS880-107-0240A-5	R6i
290	250	200	226	200	132	72	2.7	600	ACS880-107-0300A-5	R7i
326	250	250	254	200	160	72	3.2	600	ACS880-107-0340A-5	R7i
422	300	250	329	250	200	72	4.7	1300	ACS880-107-0440A-5	R8i
566	475	355	441	300	250	72	6.3	1300	ACS880-107-0590A-5	R8i
710	600	450	554	475	355	72	8.1	1300	ACS880-107-0740A-5	R8i
778	650	500	606	500	400	72	9.3	1300	ACS880-107-0810A-5	R8i
1104	950	710	860	750	560	74	12	2600	ACS880-107-1150A-5	2×R8i
1392	1200	900	1085	950	710	74	16	2600	ACS880-107-1450A-5	2×R8i
1517	1300	1000	1182	1050	800	74	18	2600	ACS880-107-1580A-5	2×R8i
2064	1850	1400	1608	1450	1100	76	24	3900	ACS880-107-2150A-5	3×R8i
2256	2000	1500	1758	1600	1200	76	27	3900	ACS880-107-2350A-5	3×R8i
2986	2650	2000	2326	2100	1600	76	36	5200	ACS880-107-3110A-5	4×R8i
3706	3200	2400	2887	2650	2000	77	44	6500	ACS880-107-3860A-5	5×R8i
4426	3750	2800	3448	3200	2400	78	53	7800	ACS880-107-4610A-5	6×R8i

NOTE: HP ratings are based on 2 or 4 pole motors and NEMA MG-1 Table 12-11 motor full load efficiencies of EPAct Efficient Electric Motors

Dimensions

Frame size	Height		Width		Depth		Weight	
	(in)	(mm)	(in)	(mm)	(in)	(mm)	(lbs)	(kg)
R1i	84.65	2150 ²⁾	15.75 to 39.37 ¹⁾	400 to 1000 ¹⁾	25.35	644 ⁴⁾	440	200
R2i	84.65	2150 ²⁾	15.75 to 39.37 ¹⁾	400 to 1000 ¹⁾	25.35	644 ⁴⁾	440	200
R3i	84.65	2150 ²⁾	15.75 to 39.37 ¹⁾	400 to 1000 ¹⁾	25.35	644 ⁴⁾	462	210
R4i	84.65	2150 ²⁾	15.75 to 39.37 ¹⁾	400 to 1000 ¹⁾	25.35	644 ⁴⁾	484	220
R6i	84.65	2150 ²⁾	15.75	400	25.35	644 ⁴⁾	572	260
R7i	84.65	2150 ²⁾	15.75	400	25.35	644 ⁴⁾	572	260
R8i	84.65	2150 ²⁾³⁾	15.75	400	25.04	636 ⁵⁾	704	320
2×R8i	84.65	2150 ²⁾³⁾	23.62	600	25.04	636 ⁵⁾	1122	510
3×R8i	84.65	2150 ²⁾³⁾	31.50	800	25.04	636 ⁵⁾	1452	660
4×R8i	84.65	2150 ²⁾³⁾	47.24	1200	25.04	636 ⁵⁾	2244	1020
5×R8i	84.65	2150 ²⁾³⁾	55.12	1400	25.04	636 ⁵⁾	2354	1070
6×R8i	84.65	2150 ²⁾³⁾	62.99	1600	25.04	636 ⁵⁾	2904	1320
7×R8i	84.65	2150 ²⁾³⁾	78.74	2000	25.04	636 ⁵⁾	3696	1680
8×R8i	84.65	2150 ²⁾³⁾	86.61	2200	25.04	636 ⁵⁾	4026	1830
9×R8i	84.65	2150 ²⁾³⁾	94.49	2400	25.04	636 ⁵⁾	4356	1980
10×R8i	84.65	2150 ²⁾³⁾	110.24	2800	25.04	636 ⁵⁾	5148	2340

¹⁾ Width depends on the number of inverters per cabinet

²⁾ Cabinet height 2315 mm for IP54 and 2051 mm for IPxxR. An additional 10 mm required for marine supports.

³⁾ 300 mm is required for the drive control unit (DCU). One can be used for two drive units.

⁴⁾ Top exit with backpack for R1i to R7i, additional depth is 200 mm.

⁵⁾ Top exit with backpack for n×R8i, additional depth is 200 mm.

Nominal ratings

I_N Rated current available continuously without overloadability at 104 °F (40 °C).

P_N Power in no-overload use.

Light-overload use

I_{Ld} Continuous current allowing 110% I_{Ld} for 1 min/5 min at 104 °F (40 °C).

P_{Ld} Power in light-overload use.

Heavy-duty use

I_{Hd} Continuous current allowing 150% I_{Hd} for 1 min/5 min at 104 °F (40 °C).

P_{Hd} Power in heavy-duty use.

The ratings apply at 104 °F (40 °C), ambient temperature. At higher temperatures (up to 122 °F (50 °C)) the derating is 1%/1.8 °F (1%/1 °C).

Ratings, types and voltages

Supply units, $U_N = 500\text{ V}$

$U_N = 500\text{ V}$ (range 380 to 500 V)											
Nominal ratings		No-over-load use	Light-overload use		Heavy-duty use		Noise level	Heat dissipation	Air flow	Type designation	Frame size
I_N	I_N	P_N	I_{Ld}	P_{Ld}	I_{Hd}	P_{Hd}					
A (AC)	A (DC)	kW (DC)	A (DC)	kW (DC)	A (DC)	kW (DC)	dB(A)	kW	cfm		

IGBT supply units (ISU), ACS880-207

396	480	340	461	326	359	254	72	4.7	1300	ACS880-207-0400A-5	R8i+BLCL-13-5
531	644	455	618	437	482	341	72	6.1	1300	ACS880-207-0530A-5	R8i+BLCL-13-5
729	884	625	849	600	661	468	72	8.7	1300	ACS880-207-0730A-5	R8i+BLCL-15-5
1035	1255	887	1205	852	939	664	74	12	2600	ACS880-207-1040A-5	2×R8i+BLCL-24-5
1422	1724	1219	1655	1170	1290	912	74	17.4	2600	ACS880-207-1420A-5	2×R8i+BLCL-25-5
2115	2564	1813	2462	1741	1918	1356	76	26	3900	ACS880-207-2120A-5	3×R8i+2×BLCL-24-5
2799	3394	2400	3258	2304	2539	1795	76	34.7	5200	ACS880-207-2800A-5	4×R8i+2×BLCL-25-5
4149	5031	3557	4829	3415	3763	2661	78	52.1	7800	ACS880-207-4150A-5	6×R8i+3×BLCL-25-5

Regenerative rectifier units (RRU), ACS880-907

600	776	514	698	494	544	385	72	5.5	2200	ACS880-907-0600A-5	R8i+BL-15-7
900	1091	772	1047	741	816	577	72	9	2200	ACS880-907-0900A-5	R8i+BL-15-7
1180	1431	1012	1374	971	1070	757	74	11.1	4100	ACS880-907-1180A-5	2×R8i+BL-25-7
1770	2146	1518	2060	1457	1605	1135	74	18.1	4100	ACS880-907-1770A-5	2×R8i+BL-25-7
2310	2801	1981	2689	1901	2095	1481	76	22.2	8200	ACS880-907-2310A-5	4×R8i+BL-25-7
3460	4195	2966	4027	2848	3138	2219	76	36.1	8200	ACS880-907-3460A-5	4×R8i+BL-25-7
5130	6220	4398	5971	4222	4653	3290	78	54.2	12300	ACS880-907-5130A-5	6×R8i+BL-25-7

Diode supply units (DSU), ACS880-307

6-pulse diode											
80	98	66	94	63	78	53	62	1.4	424	ACS880-307-0080A-5+A003	D6D
173	212	143	203	137	170	114	62	2	424	ACS880-307-0170A-5+A003	D6D
327	400	270	384	260	320	216	62	3	630	ACS880-307-0330A-5+A003	D7D
490	600	405	576	389	480	324	62	4.1	630	ACS880-307-0490A-5+A003	D7D
653	800	540	768	518	640	432	65	5.8	842	ACS880-307-0650A-5+A003	D8D
980	1200	810	1152	778	960	648	65	7.6	842	ACS880-307-0980A-5+A003	D8D
653	800	540	768	518	598	404	72	5	1300	ACS880-307-0650A-5+A018	D8T
980	1200	810	1152	778	898	606	72	7	1300	ACS880-307-0980A-5+A018	D8T
1215	1488	1004	1428	964	1113	751	74	9	2600	ACS880-307-1210A-5+A018	2×D8T
1822	2232	1507	2143	1446	1670	1127	74	13	2600	ACS880-307-1820A-5+A018	2×D8T
2734	3348	2260	3214	2170	2504	1690	76	20	3900	ACS880-307-2730A-5+A018	3×D8T
3645	4464	3013	4285	2893	3339	2254	76	27	5200	ACS880-307-3640A-5+A018	4×D8T
4556	5580	3767	5357	3616	4174	2817	77	33	6500	ACS880-307-4560A-5+A018	5×D8T
5467	6696	4520	6428	4339	5009	3381	78	40	7800	ACS880-307-5470A-5+A018	6×D8T

12-pulse diode											
911	1116	753	1071	723	835	563.0	74	8	1800	ACS880-307-0910A-5+A004+A018	2×D7T
1215	1488	1004	1428	964	1113	751.0	74	9	2600	ACS880-307-1210A-5+A004+A018	2×D8T
1822	2232	1507	2143	1446	1670	1127.0	74	13	2600	ACS880-307-1820A-5+A004+A018	2×D8T
2430	2976	2009	2857	1928	2226	1503.0	76	18	5200	ACS880-307-2430A-5+A004+A018	4×D8T
3645	4464	3013	4285	2893	3339	2254.0	76	27	5200	ACS880-307-3640A-5+A004+A018	4×D8T
5467	6696	4520	6428	4339	5009	3381.0	78	40	7800	ACS880-307-5470A-5+A004+A018	6×D8T

Dimensions (Including ACU, ICU and ISU/DSU/RRU)

Frame size	Height		Width		Depth		Weight	
	(in)	(mm)	(in)	(mm)	(in)	(mm)	(lbs)	(kg)
IGBT supply module (ISU)								
R8i+BLCL-13-5	84.45	2145	62.99	1600 ⁷⁾	25.04	636	2860	1300
R8i+BLCL-15-5	84.45	2145	39.37	1000 ⁹⁾	25.04	636	1892	860
R8i+BLCL-15-5	84.45	2145	62.99	1600 ⁷⁾	25.04	636	2860	1300
2×R8i+BLCL-24-5	84.45	2145	70.87	1800	25.04	636	3520	1600
2×R8i+BLCL-25-5	84.45	2145	70.87	1800	25.04	636	3784	1720
3×R8i+BLCL-24-5	84.45	2145	102.36	2600	25.04	636	5302	2410
4×R8i+BLCL-25-5	84.45	2145	110.24	2800	25.04	636	6204	2820
6×R8i+BLCL-25-5	84.45	2145	157.48	4000	25.04	636	8712	3960
Regenerative rectifier units (RRU)								
R8i+BL-15-7	84.45	2145	62.99	1600	25.04	636	2805	1275
R8i+BL-15-7	84.45	2145	62.99	1600	25.04	636	2805	1275
2×R8i+BL-25-7	84.45	2145	78.74	2000	25.04	636	3553	1615
2×R8i+BL-25-7	84.45	2145	78.74	2000	25.04	636	3553	1615
4×R8i+BL-25-7	84.45	2145	110.24	2800	25.04	636	5742	2610
4×R8i+BL-25-7	84.45	2145	125.98	3200	25.04	636	5742	2610
6×R8i+BL-25-7	84.45	2145	157.48	4000	25.04	636	8019	3645

Frame size	Height		Width		Depth		Weight	
	(in)	(mm)	(in)	(mm)	(in)	(mm)	(lbs)	(kg)
Diode supply (DSU) 6-pulse diode								
D6D	84.45	2145	15.75	400	25.04	636	660	300
D7D	84.45	2145	15.75	400	25.04	636	792	360
D8D	84.45	2145	27.56	700	25.04	636	1210	550
D8T	84.45	2145	55.12	1400	25.04	636	1870	850
2×D8T	84.45	2145	62.99	1600	25.04	636	2486	1130
3×D8T	84.45	2145	78.74	2000	25.04	636	3432	1560
4×D8T	84.45	2145	110.24	2800 ¹⁾	25.04	636	4708	2140 ²⁾
5×D8T	84.45	2145	118.11	3000	25.04	636	5324	2420
6×D8T	84.45	2145	125.98	3200	25.04	636	5940	2700
Diode supply (DSU) 12-pulse diode								
2×D7T	84.45	2145	70.87	1800	25.04	636	1980	900
2×D8T	84.45	2145	70.87	1800	25.04	636	2596	1180 ³⁾
4×D8T ⁴⁾	84.45	2145	94.49	2400 ²⁾	25.04	636	4048	1840
4×D8T ⁵⁾	84.45	2145	118.11	3000 ³⁾	25.04	636	4488	2040 ³⁾
6×D8T	84.45	2145	133.86	3400	25.04	636	6380	2900

1) 690 V, 2400 mm
 2) 690 V, 1940 kg
 3) 690 V, 1130 kg
 4) 2430A-3
 5) 3640A-3

6) Valid for ACS880 multidrives limited scope
 7) Valid for ACS880 multidrives

Ratings, types and voltages

Inverter units, $U_N = 690\text{ V}$

Inverter unit (INU), ACS880-107

$U_N = 690\text{ V}$ (range 525 to 690 V). The power ratings are valid at nominal voltage 690 V.

Light-overload use			Heavy-duty use			Noise level	Heat dissipation	Air flow	Type designation	Frame size
I_{Ld}	P_{Ld}		I_{Hd}	P_{Hd}						
A	hp	kW	A	hp	kW	dB(A)	kW	cfm		
6.9	7.5	5.5	5.6	5	4					
9.3	10	7.5	7.3	7.5	5.5	62	0.28	280	ACS880-107-009A8-7	R5i
13.5	10	11	9.8	10	7.5	62	0.4	280	ACS880-107-014A2-7	R5i
17.1	15	15	14.2	10	11	62	0.49	280	ACS880-107-0018A-7	R5i
20.9	20	18.5	18	15	15	62	0.58	280	ACS880-107-0022A-7	R5i
25.7	20	22	22	20	18.5	62	0.66	280	ACS880-107-0027A-7	R5i
33.3	30	30	27	20	22	62	0.86	280	ACS880-107-0035A-7	R5i
39.9	40	37	35	30	30	62	1	280	ACS880-107-0042A-7	R5i
49.4	50	45	42	40	37	62	1.12	280	ACS880-107-0052A-7	R5i
60	60	55	46	50	45	71	0.8	650	ACS880-107-0062A-7	R6i
79	75	75	61	60	55	71	1.1	650	ACS880-107-0082A-7	R6i
95	100	90	74	75	75	71	1.3	650	ACS880-107-0100A-7	R6i
120	125	110	94	75	75	71	1.5	650	ACS880-107-0130A-7	R6i
138	150	132	108	100	90	71	1.8	650	ACS880-107-0140A-7	R6i
184	200	160	144	150	132	71	2.5	650	ACS880-107-0190A-7	R6i
208	250	200	162	200	160	72	2.8	940	ACS880-107-0220A-7	R7i
259	250	250	202	250	200	72	3.3	940	ACS880-107-0270A-7	R7i
326	250	250	254	250	200	72	5.2	1300	ACS880-107-0340A-7	R8i
394	475	355	307	250	250	72	6.1	1300	ACS880-107-0410A-7	R8i
509	600	450	396	475	355	72	7.9	1300	ACS880-107-0530A-7	R8i
576	750	560	449	500	400	72	9	1300	ACS880-107-0600A-7	R8i
768	950	710	598	750	560	74	12	2600	ACS880-107-0800A-7	2×R8i
989	1200	900	770	950	710	74	15	2600	ACS880-107-1030A-7	2×R8i
1123	1300	1000	875	1050	800	74	18	2600	ACS880-107-1170A-7	2×R8i
1478	1850	1400	1152	1450	1100	76	23	3900	ACS880-107-1540A-7	3×R8i
1670	2100	1600	1302	1600	1200	76	26	3900	ACS880-107-1740A-7	3×R8i
2208	2650	2000	1720	2100	1600	76	35	5200	ACS880-107-2300A-7	4×R8i
2746	3200	2400	2139	2650	2000	77	43	6500	ACS880-107-2860A-7	5×R8i
3283	4250	3200	2558	3200	2400	78	52	7800	ACS880-107-3420A-7	6×R8i
3830	4800	3600	2985	3750	2800	78	60	9100	ACS880-107-3990A-7	7×R8i
4378	5350	4000	3411	4250	3200	79	69	10400	ACS880-107-4560A-7	8×R8i
4925	6400	4800	3837	4800	3600	79	78	11700	ACS880-107-5130A-7	9×R8i
5472	6950	5200	4264	5350	4000	79	86	13000	ACS880-107-5700A-7	10×R8i

Dimensions

Frame size	Height		Width		Depth		Weight	
	(in)	(mm)	(in)	(mm)	(in)	(mm)	(lbs)	(kg)
R5i	84.45	2145 ¹⁾	11.81-19.69	300-500 ⁵⁾	25.04	636	484	220
R6i	84.65	2150 ¹⁾	15.75	400	25.35	644 ³⁾	572	260
R7i	84.65	2150 ¹⁾	15.75	400	25.35	644 ³⁾	572	260
R8i	84.65	2150 ¹⁾²⁾	15.75	400	25.04	636 ⁴⁾	704	320
2×R8i	84.65	2150 ¹⁾²⁾	23.62	600	25.04	636 ⁴⁾	1122	510
3×R8i	84.65	2150 ¹⁾²⁾	31.50	800	25.04	636 ⁴⁾	1452	660
4×R8i	84.65	2150 ¹⁾²⁾	47.24	1200	25.04	636 ⁴⁾	2244	1020
5×R8i	84.65	2150 ¹⁾²⁾	55.12	1400	25.04	636 ⁴⁾	2354	1070
6×R8i	84.65	2150 ¹⁾²⁾	62.99	1600	25.04	636 ⁴⁾	2904	1320
7×R8i	84.65	2150 ¹⁾²⁾	78.74	2000	25.04	636 ⁴⁾	3696	1680
8×R8i	84.65	2150 ¹⁾²⁾	86.61	2200	25.04	636 ⁴⁾	4026	1830
9×R8i	84.65	2150 ¹⁾²⁾	94.49	2400	25.04	636 ⁴⁾	4356	1980
10×R8i	84.65	2150 ¹⁾²⁾	110.24	2800	25.04	636 ⁴⁾	5148	2340

Nominal ratings

I_N	Rated current available continuously without overloadability at 104 °F (40 °C).
P_N	Power in no-overload use.
Light-overload use	
I_{Ld}	Continuous current allowing 110% I_{Ld} for 1 min/5 min at 104 °F (40 °C).
P_{Ld}	Power in light-overload use.
Heavy-duty use	
I_{Hd}	Continuous current allowing 150% I_{Hd} for 1 min/5 min at 104 °F (40 °C).
P_{Hd}	Power in heavy-duty use.

The ratings apply at 104 °F (40 °C), ambient temperature. At higher temperatures (up to 122 °F (50 °C)) the derating is 1%/1.8 °F (1%/1 °C).

¹⁾ Cabinet height 2315 mm for IP54 and 2051 mm for IPxxR. An additional 10 mm required for marine supports.

²⁾ 300 mm is required for drive control unit (DCU). One DCU can be used for two drive units.

³⁾ Top exit with backpack for R11 to R71, additional depth is 130 mm

⁴⁾ Top exit with backpack for n×R8i, additional depth is 200 mm.

⁵⁾ Width depends on the amount of inverter units.

Ratings, types and voltages

Supply units, $U_N = 690\text{ V}$

$U_N = 690\text{ V}$ (range 525 to 690 V)											
Nominal ratings		No-overload use	Light-overload use		Heavy-duty use		Noise level	Heat dissipation	Air flow	Type designation	Frame size
I_N A (AC)	I_N A (DC)	P_N kW (DC)	I_{Ld} A (DC)	P_{Ld} kW (DC)	I_{Hd} A (DC)	P_{Hd} kW (DC)	dB(A)	kW	cfm		
IGBT supply units (ISU), ACS880-207											
306	371	362	356	348	278	271	72	6.2	1300	ACS880-207-0310A-7	R8i+BLCL-13-7
369	447	437	430	419	335	327	72	7.2	1300	ACS880-207-0370A-7	R8i+BLCL-13-7
540	655	639	629	613	490	478	72	10.2	1300	ACS880-207-0540A-7	R8i+BLCL-15-7
720	873	852	838	818	653	637	74	14.4	2600	ACS880-207-0720A-7	2xR8i+BLCL-24-7
1053	1277	1246	1226	1196	955	932	74	20.5	2600	ACS880-207-1050A-7	2xR8i+BLCL-25-7
1566	1899	1853	1823	1779	1420	1386	76	30.7	3900	ACS880-207-1570A-7	3xR8i+2xBLCL-24-7
2070	2510	2449	2409	2351	1877	1832	76	40.9	5200	ACS880-207-2070A-7	4xR8i+2xBLCL-25-7
3078	3732	3642	3583	3496	2792	2724	78	61.4	7800	ACS880-207-3080A-7	6xR8i+3xBLCL-25-7
4104	4976	4856	4777	4661	3722	3632	79	81.8	10400	ACS880-207-4100A-7	8xR8i+4xBLCL-25-7
5130	6220	6070	5971	5827	4653	4540	79	102.3	13000	ACS880-207-5130A-7	10xR8i+5xBLCL-25-7
Regenerative rectifier units (RRU), ACS880-907											
600	727	710	698	682	544	531	72	6.8	2200	ACS880-907-0600A-7	R8i+BL-15-7
900	1091	1065	1048	1022	816	797	72	10.3	2200	ACS880-907-0900A-7	R8i+BL-15-7
1180	1431	1396	1374	1340	1070	1044	74	13.5	4100	ACS880-907-1180A-7	2xR8i+BL-25-7
1770	2146	2094	2060	2010	1605	1566	74	20.6	4100	ACS880-907-1770A-7	2xR8i+BL-25-7
2310	2801	2733	2689	2624	2095	2044	76	27.1	8200	ACS880-907-2310A-7	4xR8i+BL-25-7
3460	4195	4094	4027	3930	3138	3062	76	41.2	8200	ACS880-907-3460A-7	4xR8i+BL-25-7
5130	6220	6070	5971	5827	4653	4540	78	61.8	12300	ACS880-907-5130A-7	6xR8i+BL-25-7
Diode supply units (DSU), ACS880-307											
6-pulse diode											
572	700	652	672	626	524	488	72	5	1300	ACS880-307-0570A-7+A018	D8T
816	1000	932	960	894	748	697	72	6	1300	ACS880-307-0820A-7+A018	D8T
1063	1302	1213	1250	1164	974	907	74	9	2600	ACS880-307-1060A-7+A018	2xD8T
1519	1860	1733	1786	1663	1391	1296	74	13	2600	ACS880-307-1520A-7+A018	2xD8T
2278	2790	2599	2678	2495	2087	1944	76	19	3900	ACS880-307-2280A-7+A018	3xD8T
3037	3720	3465	3571	3327	2783	2592	76	26	5200	ACS880-307-3040A-7+A018	4xD8T
3797	4650	4331	4464	4158	3478	3240	77	32	6500	ACS880-307-3800A-7+A018	5xD8T
4556	5580	5198	5357	4990	4174	3888	78	38	7800	ACS880-307-4560A-7+A018	6xD8T
12-pulse diode											
759	930	866	893	832	696	648	74	8	1800	ACS880-307-0760A-7+A004+A018	2xD7T
1063	1302	1213	1250	1164	974	907	74	9	2600	ACS880-307-1060A-7+A004+A018	2xD8T
1519	1860	1733	1786	1663	1391	1296	74	13	2600	ACS880-307-1520A-7+A004+A018	2xD8T
2126	2604	2426	2500	2329	1948	1814	76	18	5200	ACS880-307-2130A-7+A004+A018	4xD8T
3037	3720	3465	3571	3327	2783	2592	76	26	5200	ACS880-307-3040A-7+A004+A018	4xD8T
4556	5580	5198	5357	4990	4174	3888	78	38	7800	ACS880-307-4560A-7+A004+A018	6xD8T
Dimensions (Including ACU, ICU and ISU/DSU/RRU)											
Frame size		Height		Width		Depth		Weight			
		(in)	(mm)	(in)	(mm)	(in)	(mm)	(lbs)	(kg)		
IGBT supply module (ISU)											
R8i+BLCL-13-7	84.45	2145	62.99	1600	25.04	636	2860	1300			
R8i+BLCL-15-7	84.45	2145	62.99	1600	25.04	636	2860	1300			
2xR8i+BLCL-24-7	84.45	2145	70.87	1800	25.04	636	3520	1600			
2xR8i+BLCL-25-7	84.45	2145	70.87	1800	25.04	636	3520	1600			
3xR8i+2xBLCL-25-7	84.45	2145	102.36	2600	25.04	636	4862	2210			
4xR8i+BLCL-25-7	84.45	2145	110.24	2800	25.04	636	6204	2820			
6xR8i+BLCL-25-7	84.45	2145	141.73	3600	25.04	636	8184	3720			
8xR8i+BLCL-25-7	84.45	2145	200.79	5100	25.04	636	10692	4860			
10xR8i+BLCL-25-7	84.45	2145	232.28	5900	25.04	636	12672	5760			
Regenerative rectifier units (RRU)											
R8i+BL-15-7	84.45	2145	62.99	1600	25.04	636	2805	1275			
R8i+BL-15-7	84.45	2145	62.99	1600	25.04	636	2805	1275			
2xR8i+BL-25-7	84.45	2145	78.74	2000	25.04	636	3553	1615			
2xR8i+BL-25-7	84.45	2145	78.74	2000	25.04	636	3553	1615			
4xR8i+BL-25-7	84.45	2145	110.24	2800	25.04	636	5742	2610			
4xR8i+BL-25-7	84.45	2145	125.98	3200	25.04	636	5742	2610			
6xR8i+BL-25-7	84.45	2145	157.48	4000	25.04	636	8019	3645			
Diode supply (DSU) 6-pulse diode											
D8T	84.65	2150	55.12	1400	25.04	636	1870	850			
2xD8T	84.65	2150	62.99	1600	25.04	636	2486	1130			
3xD8T	84.65	2150	78.74	2000	25.04	636	3432	1560			
4xD8T	84.65	2150	94.49	2400	25.04	636	4268	1940			
5xD8T	84.65	2150	118.11	3000	25.04	636	5324	2420			
6xD8T	84.65	2150	125.98	3200	25.04	636	5940	2700			
Diode supply (DSU) 12-pulse diode											
2xD7T	84.65	2150	70.87	1800	25.04	636	1980	900			
2xD8T	84.65	2150	70.87	1800	25.04	636	2486	1130			
4xD8T	84.65	2150	94.49	2400 ¹⁾	25.04	636	4048	1840 ¹⁾			
4xD8T	84.65	2150	118.11	3000 ²⁾	25.04	636	4488	2040 ²⁾			
6xD8T	84.65	2150	133.86	3400	25.04	636	6380	2900			

¹⁾ 2130A-7

²⁾ 3040A-7

Standard interface and extensions for comprehensive connectivity

The ACS880 multidrives offer a wide range of standard interfaces. In addition the drive has three option slots that can be used for extensions including fieldbus adapter modules, input/

output extension modules, feedback modules and a safety functions module.

Control connections	Description
2 analog inputs (XAI)	Current input: -20 to 20 mA, R_{in} : 100 ohm Voltage input: -10 to 10 V, R_{in} > 200 kohm Resolution: 11 bit + sign bit
2 analog outputs (XAO)	0 to 20 mA, R_{load} < 500 ohm Frequency range: 0 to 300 Hz Resolution: 11 bit + sign bit
6 digital inputs (XDI)	Input type: NPN/PNP (DI1 to DI5), NPN (DI6) DI6 can alternatively be used as an input for a PTC thermistor.
Digital input interlock (DIIL)	Input type: NPN/PNP
2 digital inputs/outputs (XDIO)	As input: 24 V logic levels: "0" < 5 V, "1" > 15 V R_{in} : 2.0 kohm Filtering: 0.25 ms As output: Total output current from 24 V DC is limited to 200 mA Can be set as pulse train input and output
3 relay outputs (XRO1, XRO2, XRO3)	250 V AC/30 V DC, 2 A
Safe torque off (XSTO)	For the drive to start, both connections must be closed, only to be used in inverter units
Drive-to-drive link (XD2D)	Physical layer: EIA-485
Built-in Modbus	EIA-485
Assistant control panel/ PC tool connection	Connector: RJ-45



Control unit ZCU

Example of a typical multidrives input/output connection diagram. Variations may be possible (please see HW manual for more information).

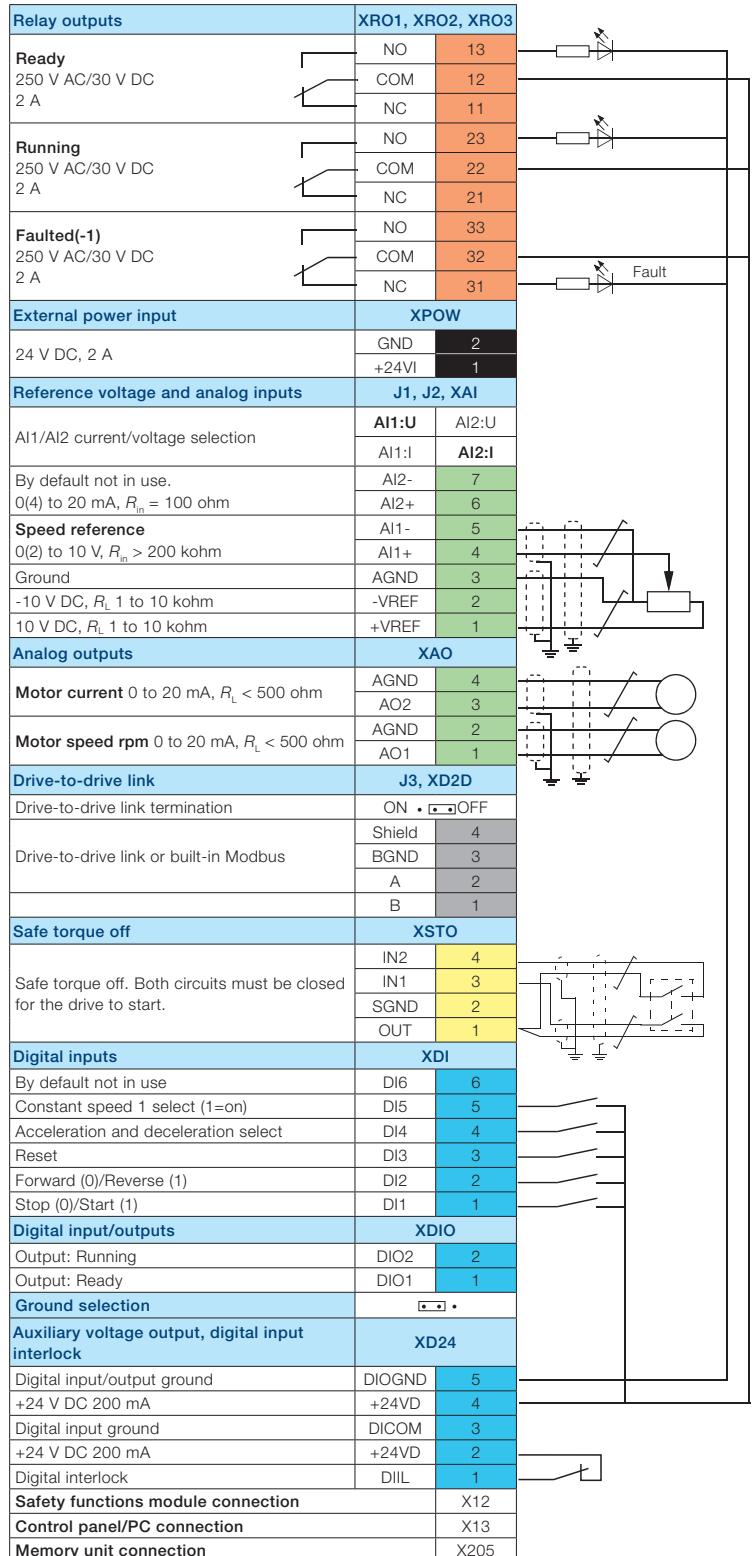

Standard software for scalable control and functionality

The same software, the primary control program, is used across the whole ACS880 series for controlling inverter units and motors. Features such as built-in pre-programmed application macros save time during configuration and drive commissioning. The application macros help set parameters for various functions including:

- Basic setup for input/output control and fieldbus adapter control
- Hand/auto control for local and remote operation
- PID control for closed loop processes
- Sequential control for repetitive cycles
- Torque control
- Four user sets, for saving multiple drive configurations

Direct torque control (DTC)

The inverters are equipped with direct torque control (DTC), ABB's signature motor control platform which supports motors such as induction motors, permanent magnet motors, servo motors and the new synchronous reluctance motor. DTC helps control the motor from standstill to maximum torque and speed without the necessity of encoders or position sensors. DTC allows high overloadability, gives high starting torque and reduces stress on mechanics.

Energy efficiency information

The inverters come with built-in energy efficiency information that helps the user fine-tune processes to ensure optimum energy use. The energy optimizer mode ensures the maximum torque per ampere, reducing energy drawn from the supply. The load profile feature collects inverter values with three loggers: two amplitude loggers and one peak value logger. Calculators provide essential energy efficiency information: used and saved electrical energy, CO₂ reduction and money saved.

Additional software features include:

- Access levels
- Adaptive programming
- Automatic reset
- Automatic start
- Constant speeds
- Critical speeds and frequencies
- DC hold
- DC magnetizing
- Diagnostics
- Drive-to-drive link for master-follower control
- Flux braking
- Jogging
- Maintenance timer and counters
- Mechanical brake control
- Motor potentiometer
- Output phase order selection, switches rotation direction of the motor
- Oscillation damping
- Power loss ride-through
- Process PID control with trim function
- Programmable and pre-programmed protection functions
- Programmable inputs and outputs
- Scalar control with IR compensation
- Speed controller with auto tuning
- Startup assistants
- User adjustable load supervision/limitation
- User selectable acceleration and deceleration ramps
- Variable slope

Removable memory unit

The removable memory unit stores the standard software that includes user settings, parameter settings and motor data. Situated on the control unit, the memory unit can easily be removed for maintenance, update or replacement purposes. This common type of memory unit is used throughout the ACS880 series.

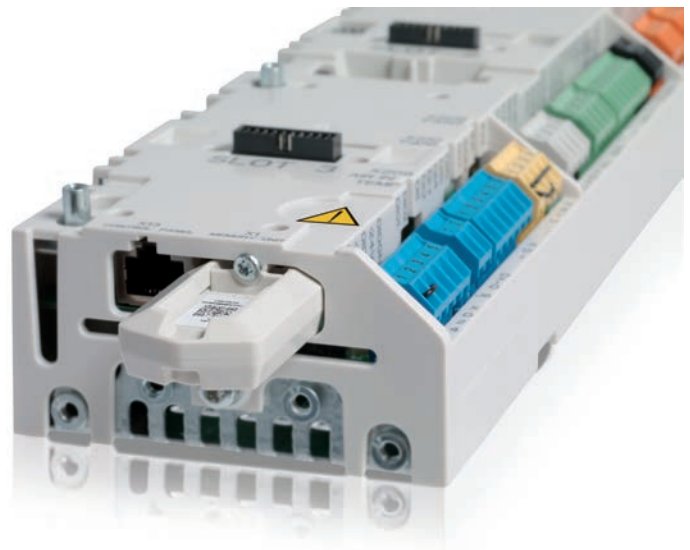

Intuitive human-machine interface

The assistant control panel features intuitive use and easy navigation. High resolution display enables visual guidance. The panel saves on commissioning and learning time by means of different assistants, making the drive simple to set up and use.

It is possible to organize parameters in different ways and store essential parameters for different configurations for any specialized application needed. The menus and messages can be customized for specific terminology so that each application can be set up and configured to its optimum performance. This makes the drive easier to use with information that is familiar to users. With the panel's text editor, users can also add information, customize text and label the drive. Powerful backup and restore functions are supported as well as different

language versions. The help key provides context sensitive guidance. Faults or warnings can be resolved quickly since the help key provides troubleshooting instructions.

One control panel can be connected to several inverters simultaneously using the panel network feature. The user can also select the inverter to operate in the panel network. The PC tool can be easily connected to the drive through the USB connector on the control panel. There is also the assistant control panel mounting platform, DPMP-01 IP55 kit available for cabinet door flush mounting.



PC tool for easy startup and maintenance

The Drive composer PC tool offers fast and harmonized setup, commissioning and monitoring for the whole drives portfolio. The free version of the tool provides startup and maintenance capabilities, while the professional version provides additional features such as custom parameter windows, control diagrams of the drive's configuration and safety settings.

The Drive composer tool is connected to the drive using an Ethernet connection or through the USB connection on the assistant control panel. All drive information such as parameters, event log and system information are gathered into a support diagnostics file with a single mouse click. This provides faster fault tracking, shortens downtime and minimizes operational and maintenance costs.

Drive composer pro

Drive composer pro provides basic functionality, including parameter settings, downloading and uploading files and search parameters. Advanced features such as graphical control diagrams and various displays are also available. The control diagrams save users from browsing long lists of parameters and help to set the drive's logic quickly and easily. The tool has fast monitoring capabilities of multiple signals from several drives in a PC tool network. Full backup and restore functions are also included. Safety settings can be configured with Drive composer pro.



Designed to control virtually any type of AC motor

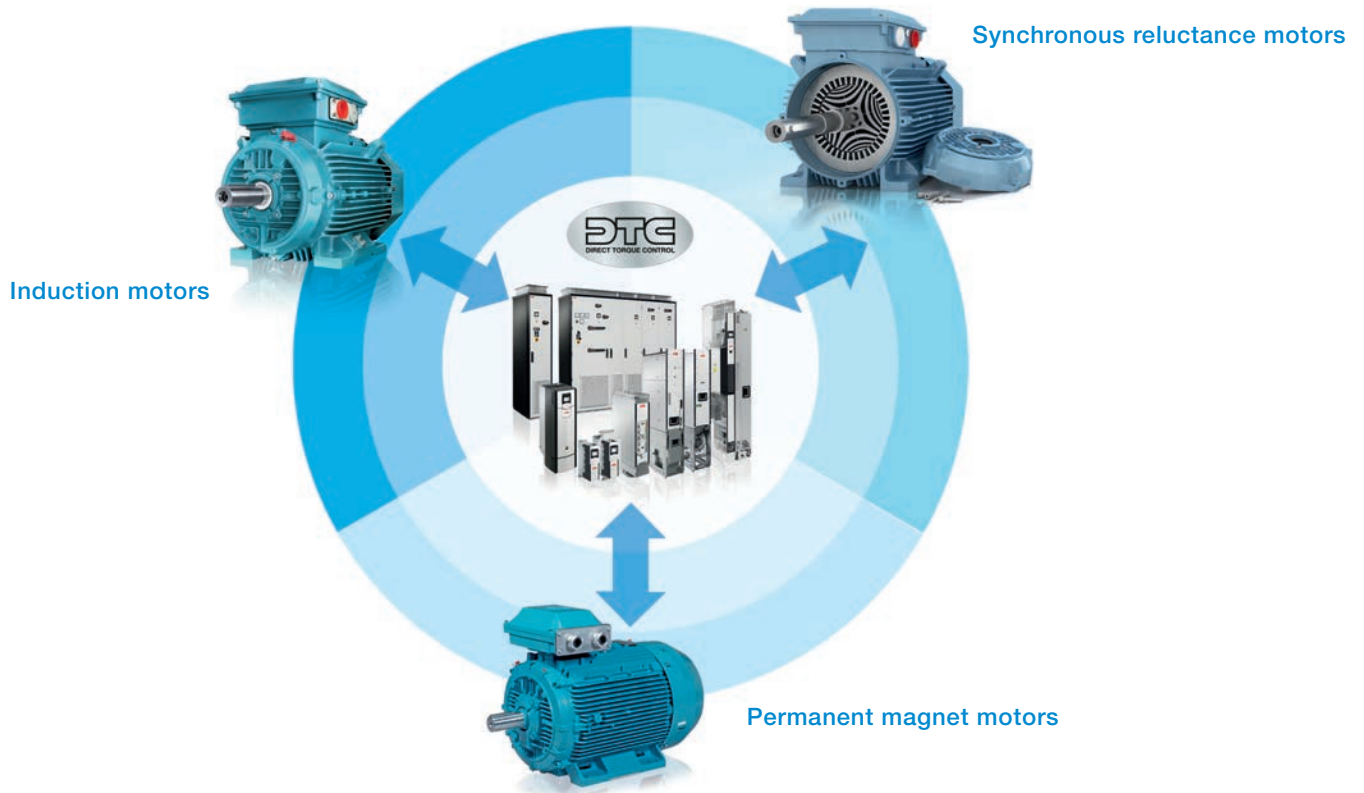

Our ACS880 drives control virtually any type of AC motor including induction, permanent magnet, servo and synchronous reluctance motors. Motor control is optimized with direct torque control (DTC), ABB's premium motor control, built-in as a standard feature in our ACS880 drives. Our robust industrial drives ensure an energy efficient and reliable motor controller with significant cost savings for the user.

Direct torque control (DTC) for optimal control of motors

To ensure optimal control of an motor, our ACS880 drives offer direct torque control (DTC) as a built-in standard feature. In majority of applications, the DTC reduces the need for an expensive speed feedback encoder. Direct torque control provides fast reaction to load changes in the motor shaft as well as reference changes on speed or torque made by the user. It makes the motor run optimally which lowers energy consumption and wear of the application.

ACS880 and induction motors form a reliable combination

Induction motors are used throughout the industry in several types of industry applications which demand robust and high enclosure motor and drive solutions. The ACS880 drives fit perfectly together with this type of motor, used in a wide range of industrial environments. The drives fit into environments that require high degree of protection and offer narrow facilities. ACS880 drives come with DTC as standard, which ensures high speed accuracy.

Because they are ATEX certified, our drives can be combined with ABB motors for explosive atmospheres.

ACS880 and permanent magnet motors for smooth operation

Permanent magnet technology is often used for improved motor characteristics such as energy efficiency, compactness and control performance. This technology is particularly well suited for low speed control industry applications, as they eliminate the need to use gear boxes. Actual characteristics between different permanent magnet motors can vary considerably. ACS880 drives with DTC can control ABB and most other permanent magnet motors without speed or rotor position sensors.

ACS880 and IE4 synchronous reluctance motors for a package with high efficiency

Combining the ACS880's control technology with our synchronous reluctance (SynRM) motors provides an IE4 motor and drive package that gives you great energy savings benefits. The key is in the rotor design. The synchronous reluctance rotor replaces the traditional induction rotor and requires no permanent magnets. ABB has tested our SynRM motor and drive packages and produced manufacturer's statements providing verified system (drive and motor) efficiency.

Integrated safety simplifies configuration

Integrated safety reduces the need for external safety components, simplifying configuration and reducing installation space. The safety functionality is a built-in feature of the ACS880, with safe torque off (STO) as standard. Additional safety functions can be commissioned with the optional and compact safety functions module that includes safe stop 1 (SS1), safe stop emergency (SSE), safely-limited speed (SLS), safe brake control (SBC), safe maximum speed (SMS) and prevention of unexpected startup (POUS). The drives' functional safety is designed according to EN/IEC 61800-5-2 and complies with the requirements of the European Union Machinery Directive 2006/42/EC.

Safe torque off as standard

Safe torque off (STO) is used to prevent unexpected startup and in stopping-related functions, enabling safe machine maintenance and operation. With safe torque off activated, the drive will not provide a rotational field. This prevents the motor from generating torque on the shaft. This function corresponds to an uncontrolled stop in accordance with stop category 0 of EN 60204-1.

The safety functions module

The easy to connect and configure safety functions module FSO-12 comes with a range of safety functions and a self-diagnostic function that meets current safety requirements and standards, in one compact module. Compared to using external safety components, the FSO-12 comes with the supported functions seamlessly integrated with the drive functionality, reducing the implementation of safety function connections and configuration. Installing FSO-12 results in less needs for cabling and provides a cost-effective solution packed into a single safety functions module to ensure safe drive operation. Commissioning and configuration of the safety functions is done with the Drive composer pro PC tool. The drive and FSO-12 are easy to connect to a safety PLC using PROFIsafe over profinet fieldbus adapter module (FENA-21). Please contact your local ABB for further information.



ACS880 multidrives with integrated safety features

The safety functions module supports the following safety functions (which achieve up to SIL 3 or PL e safety level (Cat. 3)):

- **Safe stop 1 (SS1)** brings the machine to a stop (STO) using a monitored deceleration ramp. It is typically used in applications where the machinery motion needs to be brought to a stop (stop category 1) in a controlled way before switching over to the no-torque state.
- **Safe stop emergency (SSE)** can be configured to, upon request, either activate STO instantly (category 0 stop), or first initiate motor deceleration and then, once the motor has stopped, activate the STO (category 1 stop).
- **Safe brake control (SBC)** provides a safe output for controlling the motor's external (mechanical) brakes, together with STO.
- **Safely-limited speed (SLS)** ensures that the specified speed limit of the motor is not exceeded. This allows machine interaction to be performed at slow speed without stopping the drive. FSO-12 comes with four individual SLS settings for speed monitoring.
- **Safe maximum speed (SMS)** monitors that the speed of the motor does not exceed the configured speed limit.
- **Prevention of unexpected startup (POUS)** ensures that a machine remains stopped when persons are present in a danger area. It is one of the most important conditions in safe machines.

Safety functions are designed to the multidrives on project specific requirements.

Engineered and verified solutions with safety functions module FSO-12 (+Q973)

Safety function	Option code
Emergency Stop, configurable stop cat.0 or 1; with STO, with FSO-12	+Q979 +Q973
Safely-limited speed (SLS) with FSO-12 (+Q966 +Q973)	+Q966 +Q973
Prevention of unexpected startup (POUS) with FSO-12	+Q950 +Q973

Safety data and safety levels up to SIL3 or PLe can be calculated for engineered solutions for multidrives cabinets as option.



Safety functions module, FSO-12

Drive application programming based on IEC standard 61131-3

Automation Builder, ABB's new software suite for automation engineering, makes programming of industry devices such as drives, PLC's, robots and human machine interfaces (HMI) easy using one common engineering tool. The Automation Builder is used both for engineering individual industry devices and for putting together entire automation projects. It is based on a widely used software environment that fulfills many different requirements of industrial automation projects, according to the IEC standard 61131-3. As a single tool, the Automation Builder reduces time typically needed for system configuration and programming. It also reduces the need for installing and maintaining separate programs simultaneously. Automation Builder enables the possibility to do online diagnostic checking of multiple tasks performed by different industrial devices such as ACS880 drives.

Drive application programming

Automation Builder makes it possible for system integrators and machine builders to integrate their desired functionality and know-how directly into ACS880 drives. This is possible as ACS880 drives come with programming capability embedded inside the drive. Designing an application program in the drive makes the end user application run more efficiently, even without a separate programmable controller. It also brings higher end-product quality and requires less need for installation space and wiring.

Automation Builder lets you extend the standard functionality of parameter functions for ACS880 drives. This makes the ACS880 drives very flexible to meet exact requirements set for end user applications. The library management functionality in Automation Builder shortens engineering time as reuse of existing program code is possible. Additional features include the ability to select and use one of five different programming languages, effective program debugging and user password protection.

Integrated engineering suite for operating several industry components together

Using the Drive manager tool embedded in Automation Builder together with ABB's AC500 PLC gives the user online connection to all drives in a fieldbus network. This speeds up commissioning and makes diagnostic of the entire automation system easy. Automation Builder saves all the configuration data of industry devices (including drive parameter settings) and program code to the same project archive. This makes engineering work more consistent and manageable.

The drive application programming license should be ordered together with the drive.

Drive application programmability

Option	Option code
License key ¹⁾	+N8010

¹⁾ The Automation Builder tools must be ordered separately.
For further information please contact your local ABB



Automation Builder

One engineering tool to control all industry devices
System configuration and diagnostic
IEC programming
Common project data handling

Application control programs



Our application control programs are developed by working closely with our customers over many years. This results in application programs that include the lessons learned across many customers, and that are designed to give you the flexibility to adapt the programs to your specific needs. These programs enhance application usability and lower energy consumption. They increase safe operation of the applications and reduce the need for a PLC. Other benefits include protection of machinery and optimization of application productivity. The programs also optimize time usage and lower operational costs.

The ACS880 application control programs come with adaptive programming features. This makes fine tuning of the functionality of the ready-made application control programs easy. Additionally, we understand that you may need to use different configurations in your process. That's why each of our control programs comes with the ability to configure up to four different configurations, or "user sets." The ACS880 drives offer integrated safety with safe torque off (STO) functionality as standard. The optional safety functions module comes with several safety functions including safe brake control (SBC).

Control programs for cranes

This control program is dedicated for industrial, harbor, tower and marine deck cranes. It is possible to control crane movements in hoist and trolley and travel motions using the same software. The control program comes with integrated mechanical brake control to assure safe opening and closing of the mechanical disc or drum brakes. Standalone and master-follower functionality is supported along with synchro control of multimotors. The synchro control for common operation of the load functionality makes it possible to lift and lower loads, such as containers, in a smooth and balanced way during transportation. The load speed control function maximizes the hoist speed for the given load and ensures that there is sufficient motor torque in the field weakening area. This minimizes operation time and optimizes crane capacity. Fieldbus and conventional I/O control is supported.

Control program for winder

This control program makes sure that unwinding and winding of a roll of web material, such as textile, plastic and paper is performed optimally. The control program observes the diameter of rolls and tension of the web material and makes sure that the drives controlling different parts of the winder are in sync. Based on the feedback from the dancer or tension measurement of the web, the speed or torque of the drive is adjusted properly. The result is a straightforward, cost-effective solution in web handling. Another feature is the mechanics ID run function that calculates automatically the inertia and friction of the roll. This speeds up the commissioning of the drive.

Control program for artificial oil lifting

This control program increases oil production for PCP (progressive cavity pumps), ESP (electro submersible pumps) or rod pumps. The program does not require any feedback encoder to work, which saves costs and increases reliability. The software also reduces stress on the complete pump system when optimizing fluid production. Backspin functionality is especially suitable for PCP and ESP pumps, which minimizes failure and makes oil pumping safe. Various startup ramp functions are also available. The sensorless control function (pump off control) helps to optimize oil pumping productivity by keeping the energy usage on a predetermined level.

Control program for centrifuge/decanter

This control program is designed to perform practical programmable sequences for conventional centrifuges. The program optimizes the separation of solids from the liquids in centrifuges, separators or decanter centrifuges. The speed difference of the bowing and scrolling in the decanter centrifuge is controlled by the drive-to-drive functionality available in ACS880 drives.

Flexible connectivity to automation networks

Our fieldbus adapter modules enable communication between drives, systems, devices and software. Our industrial drives are compatible with a wide range of fieldbus protocols.

The plug-in fieldbus adapter module can easily be mounted inside the drive. Other benefits include reduced wiring costs when compared with traditional input/output connections. Fieldbus systems are also less complex than conventional systems, resulting in less overall maintenance.

Multiple fieldbus connections for flexible control

ACS880 supports two fieldbus connections simultaneously. The user has flexibility of choice for control modes, and the possibility for redundant fieldbus adapters using the same protocol.

Drive monitoring

A set of drive parameters and/or actual signals, such as torque, speed, current, etc., can be selected for cyclic data transfer, providing fast data access.

Drive diagnostics

Accurate and reliable diagnostic information can be obtained through the alarm, limit and fault words.

Drive parameter handling

The Ethernet fieldbus adapter module allows users to build an Ethernet network for drive monitoring and diagnostic and parameter handling purposes.

Cabling

Substituting the large amount of conventional drive control cabling and wiring with a single cable reduces costs and increases system reliability and flexibility.

Design

The use of fieldbus control reduces engineering time at installation due to the modular structure of the hardware and software and the simplicity of the connections to the drives.

Commissioning and assembly

The modular machine configuration allows pre-commissioning of single machine sections and provides easy and fast assembly of the complete installation.

Universal communication with ABB fieldbus adapters

The ACS880 supports the following fieldbus protocols:

Fieldbus adapter modules

Option	Option code	Fieldbus protocol
FPBA-01	+K454	PROFIBUS DP, DPV0/DPV1
FCAN-01	+K457	CANopen®
FDNA-01	+K451	DeviceNet™
FENA-11	+K473	1 port EtherNet/IP™, Modbus TCP, PROFINET IO, PROFIsafe ¹⁾
FENA-21	+K475	2 port EtherNet/IP™, Modbus TCP, PROFINET IO, PROFIsafe ¹⁾
FECA-01	+K469	EtherCAT®
FSCA-01	+K458	Modbus RTU
FEPL-02	+K470	PowerLink
FCNA-01	+K462	ControlNet™

¹⁾ For the PROFIsafe to work PROFINET fieldbus adapter module (FENA-11/-21) and the safety functions module (FSO-12) are required.



ACS880 multidives with fieldbus adapters and feedback interface modules



Input/output extension modules for increased connectivity

Standard input and output can be extended by using optional analog and digital input/output extension modules. The modules are easily installed in the extension slots located on the control unit.

Analog and digital input/output extension modules

Option	Option code	Connections
FIO-01	+L501	4×DI/O, 2×RO
FIO-11	+L500	3×AI (mA/V), 1×AO (mA), 2×DI/O
FAIO-01	+L525	2×AI (mA/V), 2×AO (mA)

FIO-01



Speed feedback interfaces for precise process control

ACS880 drives can be connected to various feedback devices, such as HTL pulse encoder, TTL pulse encoder, absolute encoder and resolver. The optional feedback module is installed in the option slot on the drive. It is possible to use two feedback modules at the same time, either of the same type or different type.

Feedback interface modules

Option	Option code	Connections
FEN-01	+L517	2 inputs (TTL pulse encoder), 1 output
FEN-11	+L518	2 inputs (SinCos absolute, TTL pulse encoder), 1 output
FEN-21	+L516	2 inputs (Resolver, TTL pulse encoder), 1 output
FEN-31	+L502	1 input (HTL pulse encoder), 1 output

FEN-21



I/O option extension adapter

For additional I/O option slots the FEA-03 is suitable for this use. An analog and digital input/output extension and speed feedback interface can be installed on the FEA-03. Two extension modules can be installed on each I/O extension slot. The connection to the control unit is via a fiber optic link and the adapter can be mounted on a DIN rail (35 x 7.5 mm).

I/O extension adapter

Option	Option code	Connections
FEA-03 ¹⁾	+L515	2×F-type option extension slots

¹⁾ Please check availability from your local ABB.

DDCS communication option modules

The FDCO-0X (used in the ZCU control unit) and RDCO-0X (used in the BCU control unit) optical DDCS communication options are add-on modules on the ACS880 industrial drives control unit. The modules include connectors for two fiber optic DDCS channels. The DDCS communication option modules make it possible to perform master-follower and AC 800M communication.

Option	Option code	Connections
FDCO-01	+L503	Optical DDCS (10 Mbd/10 Mbd)
FDCO-02	+L508	Optical DDCS (5 Mbd/10 Mbd)
RDCO-04	+L509	Optical DDCS (10 Mbd/10 Mbd/10 Mbd/10 Mbd)

Remote monitoring access worldwide

The remote monitoring tool, NETA-21, gives easy access to the drive via the Internet or local Ethernet network. NETA-21 comes with a built-in web server. Being compatible with standard web browsers, it ensures easy access to a web-based user interface. Through the interface the user can configure drive parameters, monitor drive log data, and follow up load levels, run time, energy consumption, I/O data and bearing temperature of the motor connected to the drive.

The user can access the remote monitoring tool web page using 3G modem from anywhere with a standard PC, tablet or a mobile phone. The remote monitoring tool helps to reduce cost when personnel are able to monitor or perform maintenance for unmanned or manned applications in a range of industries. It is also very useful when more than one user wants to access the drive from several locations.

Enhanced monitoring functions

The remote monitoring tool supports process and drive data logging. Values of process variables or drives actual values can be logged to NETA-21's SD memory card which is situated in the remote monitoring tool or sent forward to a centralized database. NETA-21 does not need an external database as the remote monitoring tool is able to store valuable data of the drive during its entire lifetime.

Unmanned monitoring of processes or devices is ensured by the built-in alarm functions that notify maintenance personnel if a safety level is reached. Alarm history with true time stamps are stored internally to the memory card as well as technical data, which is provided by the drive for troubleshooting purposes. True time stamps are also used with drives that do not have a real time clock as standard for ensuring events of all connected drives.



NETA-21

EMC – electromagnetic compatibility

Each ACS880 model can be equipped with a built-in filter to reduce high frequency emissions.

EMC standards

The EMC product standard (EN 61800-3 (2004)) covers the specific EMC requirements stated for drives (tested with motor and cable) within the EU. EMC standards such as EN 55011 or EN 61000-6-3/4 are applicable to industrial and domestic equipment and systems including components inside the drive. Supply units complying with the requirements of EN 61800-3 are compliant with comparable categories in EN 55011 and EN 61000-6-3/4, but not necessarily vice versa. EN 55011 and EN 61000-6-3/4 do not specify cable length or

require a motor to be connected as a load. The emission limits are comparable to EMC standards according to the table below.

1st environment versus 2nd environment

1st environment includes domestic premises. It also includes establishments directly connected without an intermediate transformer to a low voltage power supply network that supplies buildings used for domestic purposes.

2nd environment includes all establishments other than those directly connected to a low voltage power supply network that supplies buildings used for domestic purposes.

EMC standards

EMC according to EN 61800-3 (2004) product standard	EN 61800-3 product standard	EN 55011, product family standard for industrial, scientific and medical (ISM) equipment	EN 61000-6-4, generic emission standard for industrial environments	EN 61000-6-3, generic emission standard for residential, commercial and light-industrial environment
2 nd environment, unrestricted distribution	Category C3	Group 2, Class A	Not applicable	Not applicable
2 nd environment, restricted distribution	Category C4	Not applicable	Not applicable	Not applicable

Type	Voltage	Frame sizes	2 nd environment, C3, grounded network (TN) and ungrounded network (IT) Option code
ACS880-307	380 to 500 V	D6D to D8D	With option +E210 *
ACS880-207	380 to 500 V	R8i	With option +E210 *
ACS880-307	380 to 690 V	D7T to nxD8T	With option +E210 *

* Conducted emission and immunity are fulfilled with standard filtering.
Radiated emission and immunity are as option (Cabinet construction).

Sine filters

Together with a sine filter, ACS880 drives offer smooth motor operation. The sine filter suppresses high frequency components of the motors output voltage, creating almost a sinusoidal voltage wave form for the motor. The filter offers optimized LC design that takes into account switching frequency, voltage drop and filtering characteristics.

The ACS880 inverter and sine filter solution can be used together with a variety of requirements for products and components:

- For motors which don't have adequate insulation for the drives duty
- Where the total motor cable length is long as a result of a number of parallel motors
- For step-up applications eg where medium voltage motor needs to be driven
- For submersible pumps with long motor cables eg in the oil industry
- When the motor noise needs to be reduced
- When there are industry specific requirements for peak voltage level and voltage rise time

I_N A	P_N kW	Inverter type designation	Filter size	Filter								Noise level dB	Frame size
				Height		Width		Depth		Weight			
				in	mm	in	mm	in	mm	lbs	kg		
$U_N = 500$ V (range 380 to 500 V). The power ratings are valid at nominal voltage 500 V.													
440	250	ACS880-107-0440A-5	NSIN-0485-6	84.45	2145	15.75	400	25.04	636	770	350	80	R8i
590	400	ACS880-107-0590A-5	NSIN-0900-6	84.45	2145	39.37	1000	25.04	636	1210	550	80	R8i
740	500	ACS880-107-0740A-5	NSIN-0900-6	84.45	2145	39.37	1000	25.04	636	1210	550	80	R8i
810	560	ACS880-107-0810A-5	NSIN-1380-6	84.45	2145	39.37	1000	25.04	636	1650	750	81	R8i
1150	800	ACS880-107-1150A-5	NSIN-1380-6	84.45	2145	39.37	1000	25.04	636	1650	750	81	2xR8i
1450	1000	ACS880-107-1450A-5	2xNSIN-0900-6	84.45	2145	78.74	2000	25.04	636	2420	1100	82	2xR8i
1580	1100	ACS880-107-1580A-5	2xNSIN-1380-6	84.45	2145	78.74	2000	25.04	636	3300	1500	82	2xR8i
2150	1500	ACS880-107-2150A-5	2xNSIN-1380-6	84.45	2145	78.74	2000	25.04	636	3300	1500	82	3xR8i
2350	1600	ACS880-107-2350A-5	3xNSIN-1380-6	84.45	2145	118.11	3000	25.04	636	4950	2250	83	3xR8i
3110	2000	ACS880-107-3110A-5	3xNSIN-1380-6	84.45	2145	118.11	3000	25.04	636	4950	2250	83	4xR8i
3860	2400	ACS880-107-3860A-5	4xNSIN-1380-6	84.45	2145	157.48	4000	25.04	636	6600	3000	84	5xR8i
4610	3200	ACS880-107-4610A-5	5xNSIN-1380-6	84.45	2145	196.85	5000	25.04	636	8250	3750	85	6xR8i
$U_N = 690$ V (range 525 to 690 V). The power ratings are valid at nominal voltage 690 V.													
340	315	ACS880-107-0340A-7	NSIN-0485-6	84.45	2145	15.75	400	25.04	636	770	350	80	R8i
410	400	ACS880-107-0410A-7	NSIN-0485-6	84.45	2145	15.75	400	25.04	636	770	350	80	R8i
530	500	ACS880-107-0530A-7	NSIN-0900-6	84.45	2145	39.37	1000	25.04	636	1210	550	80	R8i
600	560	ACS880-107-0600A-7	NSIN-0900-6	84.45	2145	39.37	1000	25.04	636	1210	550	80	R8i
800	800	ACS880-107-0800A-7	NSIN-0900-6	84.45	2145	39.37	1000	25.04	636	1210	550	80	2xR8i
1030	1000	ACS880-107-1030A-7	NSIN-1380-6	84.45	2145	39.37	1000	25.04	636	1650	750	81	2xR8i
1170	1100	ACS880-107-1170A-7	NSIN-1380-6	84.45	2145	39.37	1000	25.04	636	1650	750	81	2xR8i
1540	1400	ACS880-107-1540A-7	2xNSIN-1380-6	84.45	2145	78.74	2000	25.04	636	3300	1500	82	3xR8i
1740	1600	ACS880-107-1740A-7	2xNSIN-1380-6	84.45	2145	78.74	2000	25.04	636	3300	1500	82	3xR8i
2300	2000	ACS880-107-2300A-7	2xNSIN-1380-6	84.45	2145	78.74	2000	25.04	636	3300	1500	82	4xR8i
2860	2800	ACS880-107-2860A-7	3xNSIN-1380-6	84.45	2145	118.11	3000	25.04	636	4950	2250	83	5xR8i
3420	3200	ACS880-107-3420A-7	3xNSIN-1380-6	84.45	2145	118.11	3000	25.04	636	4950	2250	83	6xR8i
3990	3600	ACS880-107-3990A-7	4xNSIN-1380-6	84.45	2145	157.48	4000	25.04	636	6600	3000	84	7xR8i
4560	4400	ACS880-107-4560A-7	4xNSIN-1380-6	84.45	2145	157.48	4000	25.04	636	6600	3000	84	8xR8i
5130	4800	ACS880-107-5130A-7	5xNSIN-1380-6	84.45	2145	196.85	5000	25.04	636	8250	3750	85	9xR8i
5700	5600	ACS880-107-5700A-7	6xNSIN-1380-6	84.45	2145	236.22	6000	25.04	636	9900	4500	86	10xR8i

Note: Noise level is a combined value for the drive and the filter. Heat dissipation is a combined value for the drive and the filter.

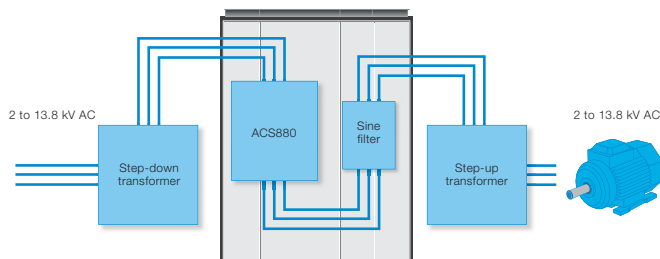

For step-up applications eg where medium voltage motor needs to be driven

Nominal ratings	
I_N	Rated current of the drive-filter combination available continuously without overload at 40 °C.
P_N	Typical motor power

Brake options, ACS880-607

Brake unit

The brake unit is a cabinet-built option. It handles the energy generated by a decelerating motor. The brake chopper connects the brake resistor to the intermediate DC circuit whenever the voltage in the circuit exceeds the limit defined by the control program. Energy consumption by the resistor losses lowers the voltage until the resistor can be disconnected.

Dynamic braking unit

A brake chopper for application where high continuous braking power is needed. The power range is 500 to 6500 kW.



NBRA659 brake unit

Brake units ACS880-607 1-phase brake units

$U_N = 500 \text{ V}$ (range 380 to 500 V)

Nominal ratings					Duty cycle (1min/5min)	Duty cycle (10s/60s)	Height ²⁾	Width ^{1) 3)}	Width	Noise	Air flow	Type designation	Module type	Resistor type
$P_{br,max}$ kW	R ohm	I_{max} A	I_{rms} A	$P_{cont.}$ kW	$P_{br.}$ kW	I_{rms} A	mm	mm	mm	dB(A)	m ³ /h			

Brake unit without brake resistor

403	1.43	571	136	109	317	391	403	498	2130	400	110	64	660	ACS880-607-0400-5	NBRA659	-
806	2x1.43	1142	272	218	634	782	806	996	2130	800	220	67	1320	ACS880-607-0800-5	2xNBRA659	-
1208	0.4767	1713	408	327	951	1173	1209	1494	2130	1200	330	68	1980	ACS880-607-1200-5	3xNBRA659	-
1611	0.3575	2284	544	436	1268	1564	1612	1992	2130	1600	440	69	2640	ACS880-607-1600-5	4xNBRA659	-
2014	0.286	2855	680	545	1585	1955	2015	2490	2130	2000	550	70	3300	ACS880-607-2000-5	5xNBRA659	-
2417	0.2383	3426	816	654	1902	2346	2418	2988	2130	2400	660	71	3960	ACS880-607-2400-5	6xNBRA659	-

$U_N = 690 \text{ V}$ (range 525 to 690 V)

Nominal ratings					Duty cycle (1min/5min)	Duty cycle (10s/60s)	Height ²⁾	Width ^{1) 3)}	Width	Noise	Air flow	Type designation	Module type	Resistor type
$P_{br,max}$ kW	R ohm	I_{max} A	I_{rms} A	$P_{cont.}$ kW	$P_{br.}$ kW	I_{rms} A	mm	mm	mm	dB(A)	m ³ /h			

Brake unit without brake resistor

404	2.72	414	107	119	298	267	404	361	2130	400	110	64	660	ACS880-607-0400-7	NBRA669	-
807	1.36	828	214	238	596	534	808	722	2130	800	110	67	660	ACS880-607-0800-7	2xNBRA669	-
1211	0.9067	1242	321	357	894	801	1212	1083	2130	1200	220	68	1320	ACS880-607-1200-7	3xNBRA669	-
1615	0.68	1656	428	476	1192	1068	1616	1444	2130	1600	330	69	1980	ACS880-607-1600-7	4xNBRA669	-
2019	0.544	2070	535	595	1490	1335	2020	1805	2130	2000	440	70	2640	ACS880-607-2000-7	5xNBRA669	-
2422	0.4533	2484	642	714	1788	1602	2424	2166	2130	2400	550	71	3300	ACS880-607-2400-7	6xNBRA669	-

E_r Energy pulse that the resistor assembly will withstand with the 400 seconds duty cycle. This energy will heat the resistor element from 40 °C to the maximum allowable temperature.

$P_{br,max}$ Maximum braking power of the NBRA-6xx chopper and SAFUR resistor combination.

Note: The braking energy transmitted to the resistor during any period shorter than 400 seconds may not exceed E_r .

Thus, the standard resistor withstands continuous braking of $P_{br,max}$ typically 20 to 40 seconds ($t = E_r / P_{br,max}$) during the total cycle time of 400 s.

R Recommended braking resistor resistance. Also nominal resistance of corresponding SAFUR resistor. Dedicated resistor for each brake chopper.

I_{max} Maximum peak current per chopper during braking. Current is achieved with minimum resistor resistance.

I_{rms} Corresponding rms current per chopper during load cycle.

Heat loss of brake chopper is 1% of braking power. Heat loss of section with brake resistors is the same as braking power.

¹⁾ Additional 200 mm junction section needed.

²⁾ 2130 mm + additional 10 mm is required for marine supports.

³⁾ Total width of the line-up is the sum of widths of the sections + 30 mm for the end plates.

* D151 = braking resistor, degree of protection IP22 and IP42 only

Brake units

ACS880-607 3-phase dynamic brake units

ACS880-607 brake chopper (no resistors)

$U_N = 500\text{ V}$ (range 380 to 500 V)

Resistors values		Ratings R_{min}									Ratings R_{max}						Type designation	Frame size		
		No-overload use			Cycle load (1 min/5 min)			No-overload use			Cycle load (1 min/5 min)									
R_{min} ohm	R_{max} ohm	I_{dc} A DC	I_{rms} A DC	$P_{cont.max}$ kW	I_{max} kW	I_{dc} A DC	I_{rms} A DC	R_{min} A DC	$P_{br.}$ A DC	R_{min} A DC	I_{dc} A DC	I_{rms} A DC	$P_{cont.max}$ kW	I_{max} kW	I_{dc} A DC	I_{rms} A DC	R_{max} A DC	$P_{br.}$ A DC	R_{max} A DC	
2.2	2.6	781	310	630	370	999	351	800	781	284	630	312	835	293	670				ACS880-607-0630-5	R8i
1.4	1.7	1171	465	940	555	1499	527	1210	1171	430	940	468	1277	449	1030				ACS880-607-0940-5	R8i
2.2	2.6	1562	621	1260	740	1998	702	1610	1562	568	1260	625	1671	587	1340				ACS880-607-1260-5	2xR8i
1.4	1.7	2342	931	1880	1110	2997	1053	2410	2342	860	1880	937	2555	898	2060				ACS880-607-1880-5	2xR8i
1.4	1.7	3514	1396	2830	1665	4496	1580	3620	3514	1289	2830	1405	3832	1347	3080				ACS880-607-2830-5	3xR8i
1.4	1.7	4685	1862	3770	2220	5994	2106	4820	4685	1719	3770	1874	5110	1795	4110				ACS880-607-3770-5	4xR8i
1.4	1.7	5856	2327	4710	2775	7493	2633	6030	5856	2149	4710	2342	6387	2244	5140				ACS880-607-4710-5	5xR8i

$U_N = 690\text{ V}$ (range 525 to 690 V)

Resistors values		Ratings R_{min}									Ratings R_{max}						Type designation	Frame size		
		No-overload use			Cycle load (1 min/5 min)			No-overload use			Cycle load (1 min/5 min)									
R_{min} ohm	R_{max} ohm	I_{dc} A DC	I_{rms} A DC	$P_{cont.max}$ kW	I_{max} kW	I_{dc} A DC	I_{rms} A DC	R_{min} A DC	$P_{br.}$ A DC	R_{min} A DC	I_{dc} A DC	I_{rms} A DC	$P_{cont.max}$ kW	I_{max} kW	I_{dc} A DC	I_{rms} A DC	R_{max} A DC	$P_{br.}$ A DC	R_{max} A DC	
3	3.6	781	310	870	370	999	351	1110	781	283	870	312	833	293	920				ACS880-607-0870-7	R8i
2	2.4	1171	465	1300	555	1499	527	1660	1171	425	1300	468	1249	439	1390				ACS880-607-1300-7	R8i
3	3.6	1562	621	1730	740	1998	702	2220	1562	567	1730	625	1665	585	1850				ACS880-607-1730-7	2xR8i
2	2.4	2342	931	2600	1110	2997	1053	3330	2342	850	2600	937	2498	878	2770				ACS880-607-2600-7	2xR8i
2	2.4	3514	1396	3900	1665	4496	1580	4990	3514	1275	3900	1405	3746	1316	4160				ACS880-607-3900-7	3xR8i
2	2.4	4685	1862	5200	2220	5994	2106	6650	4685	1700	5200	1874	4995	1755	5540				ACS880-607-5200-7	4xR8i
2	2.4	5856	2327	6500	2775	7493	2633	8320	5856	2125	6500	2342	6244	2194	6930				ACS880-607-6500-7	5xR8i

Dimensions

Frame size	Height ¹⁾ mm	Width bottom exit mm	Width top exit mm	Depth mm	Noise level ²⁾ dB(A)	Air flow m ³ /h
R8i	2145	500	700	636	72	1300
R8i	2145	500	700	636	72	1300
2xR8i	2145	1000	1400	636	74	2600
2xR8i	2145	1000	1400	636	74	2600
3xR8i	2145	1500	2100	636	76	3900
4xR8i	2145	2000	2800	636	76	5200
5xR8i	2145	2500	3500	636	77	6500

¹⁾ IP21 and IP42, IP54 additional 170 mm to the height of each R8i cabinet.

²⁾ Average noise level with controlled cooling fan.

Note: 400 mm free space needed above cabinet.

Resistor

R_{min} Minimum allowed resistance value of the brake resistor for one phase of the brake module.

R_{max} Resistance value of the brake resistor for one phase of the brake module corresponding to the maximum achieved continuous braking power.

Note: Connect one resistor per brake module phase. For example, a brake unit of frame size 2xR8i including two brake modules -> 2x3 resistors are needed.

Typical ratings for no-overload use

I_{dc} Total input DC current of brake unit.

I_{rms} Total rms DC output phase current of brake unit.

I_{max} Peak brake current (DC) per chopper module phase.

$P_{cont.max}$ Maximum continuous braking power per brake unit.

Cyclic load (1 min/5 min)

I_{dc} Total input DC current of brake unit during a period of 1 minute with braking power $P_{br.}$

I_{rms} Total rms DC current per brake unit phase during a period of 1 minute with braking power $P_{br.}$

$P_{br.}$ Short term braking power

Dimensioning tool for selecting the optimal drive

DriveSize is designed to help select the optimal drive, motor or transformer for the application. Based on data supplied by the user, the tool calculates and suggests which drive and motors to use. DriveSize uses technical specifications found in our technical catalogs and manuals. It provides default values which can be changed by the user.

DriveSize creates documents for drive and motor dimensioning based on the load, network and cooling data provided by the user. Dimensioning results can be viewed graphically and numerically in the tool.

The tool can be used to calculate currents and network harmonics for a single supply unit or a whole system. The user can import a user-defined motor database by using a separate template that comes with the installation package. DriveSize is easy to use and has shortcut keys to make navigation quicker.

Easy to access and use

DriveSize is a free software and can be used either online or downloaded for PC from www.abb.com/drives.



Summary of features and options

Power and voltage range 1.5 to 7500 hp, 500 to 690 V 1.5 to 5600 kW, 400 to 690 V	Ordering code	ACS880-107 inverters	ACS880-207 ISU (IGBT supply unit)	ACS880-307 DSU (diode supply unit) (6-pulse)	ACS880-307 DSU (diode supply unit) (6- and 12-pulse)	ACS880-907 RRU (regenerative rectifier unit) ¹⁰⁾	ACS880-607 Brake units ¹⁴⁾
		Frame sizes R1i to n×R8i	Frame sizes n×R8i	Frame sizes D6D to D8D	Frame sizes D7T and n×D8T	Frame sizes n×R81	Frame sizes n×R81
Mounting							
Free-standing		●	●	●	●	●	●
Cabling							
Supply bottom entry		–	●	●	●	●	–
Supply top entry		–	□	□	□	□	–
Inverter bottom exit		●	–	–	–	–	●
Inverter top exit		□	–	–	–	–	□
Degree of protection							
IP22 (UL type 1)		●	●	●	●	●	●
IP42 (UL type 1)		□	□	□	□	□	□ ¹⁾
IP54 (UL type 12)		□	□	□	□	□	□ ¹⁾
Motor control							
DTC (direct torque control)		●	–	–	–	–	–
Software							
Primary control program, for more details see section: Drive application programming based on IEC 61131-3		●	□	–	–	□	–
Drive application programming based on IEC61131-3 using Automation Builder	+N8010	□	–	–	–	–	–
Application control program for winder	+N5000	□ ³⁾	–	–	–	–	–
Application control program for crane	+N5050	□ ³⁾	–	–	–	–	–
Application control program for centrifuge/ decanter	+N5150	□ ³⁾	–	–	–	–	–
Application control program for PCP/ESP pump	+N5200	□ ³⁾	–	–	–	–	–
Application control program for rod pump	+N5250	□ ³⁾	–	–	–	–	–
Support for asynchronous motor		●	–	–	–	–	–
Support for permanent magnet motor		●	–	–	–	–	–
Support for synchronous reluctance motor (SynRM)	+N7502	□	–	–	–	–	–
Reduced run (redundancy) for parallel connected R8i		●	–	–	–	–	–
Control panel							
Intuitive control panel		□	□	□	□	□	□ ¹³⁾
Control connections (I/O) and communications							
2 pcs analog inputs, programmable, galvanically isolated		●	●	●	●	●	● ¹³⁾
2 pcs analog outputs, programmable		●	●	●	●	●	● ¹³⁾
6 pcs digital inputs, programmable, galvanically isolated - can be divided into two groups		●	●	●	●	●	● ¹³⁾
2 pcs digital inputs/outputs		●	●	●	●	●	● ¹³⁾
1 pcs digital input interlock		●	●	●	●	●	● ¹³⁾
3 pcs relay outputs programmable		●	●	●	●	●	● ¹³⁾
Safe torque off (STO)		●	–	–	–	–	● ¹³⁾
Drive-to-drive link/Built-in Modbus		●	●	●	●	●	● ¹³⁾
Assistant control panel/PC tool connection		●	●	●	●	●	● ¹³⁾
Possibility for external power supply for control unit		□	□	□	□	□	□
Built-in I/O extension and speed feedback modules: for more details see sections: "Input/output extension modules for increased connectivity", "Speed feedback interfaces for precise process control" and "DDCS communication option modules"		□	□	□	□	□	□
Built-in adapters for several fieldbuses: for more details see section "Flexible connectivity to automation networks"		□	□	□	□	□	□

Summary of features and options

Power and voltage range 1.5 to 7500 hp, 500 to 690 V 1.5 to 5600 kW, 400 to 690 V	Ordering code	ACS880-107 inverters	ACS880-207 ISU (IGBT supply unit)	ACS880-307 DSU (diode supply unit) (6-pulse)	ACS880-307 DSU (diode supply unit) (6- and 12-pulse)	ACS880-907 RRU (regenerative rectifier unit) ¹⁰⁾	ACS880-607 Brake units ¹⁴⁾
		Frame sizes R1i to n×R8i	Frame sizes n×R8i	Frame sizes D6D to D8D	Frame sizes D7T and n×D8T	Frame sizes n×R81	Frame sizes n×R81
EMC filters							
EMC 1 st environment, unrestricted distribution (category C2)	+E202	–	□ ³⁾	–	□ ¹⁵⁾	□ ³⁾	–
EMC 2 nd environment, unrestricted distribution (category C3)	+E210	□ ⁷⁾	□ ⁷⁾	□ ⁷⁾	□ ⁷⁾	□ ⁷⁾	□ ⁷⁾
Line filter							
AC or DC choke		–	–	●	●	–	–
LCL		–	●	–	–	–	–
L		–	–	–	–	●	–
Output filters							
Common mode filter	+E208	● ⁸⁾	● ⁸⁾	–	–	● ⁸⁾	–
du/dt filters	+E205	● ⁹⁾	●	–	–	●	–
Braking (see braking unit table)							
Incoming unit apparatus							
Disconnecter		–	● ¹¹⁾	●	● ⁵⁾	●	●
Air circuit breaker	+F255	–	● ¹²⁾	●	● ⁵⁾	–	–
Line contactor	+F250	–	● ¹¹⁾	□	□	●	–
Earthing switch	+F259	–	□	□	□	□	–
Inverter units							
DC switch	+F286	□ ⁶⁾	–	–	–	–	–
Safety options							
Safe torque off (STO)		●	–	–	–	–	–
Prevention of unexpected startup with safety relay(s)	+Q957	□	–	–	–	–	–
Prevention of unexpected startup with STO and FSO-12	+Q950 +Q973	□	–	–	–	–	–
Emergency stop, category 0 with opening the main contactor/breaker, with safety relay	+Q951	□	□	□	□	□	–
Emergency stop, category 1 with opening the main contactor/breaker, with safety relay	+Q952	□	□	□	□	□	–
Emergency stop, category 0 with STO, with safety relay	+Q963	□	□	□	□	□	–
Emergency stop, category 1 with STO, with safety relay	+Q964	□	□	□	□	□	–
Safely limited-speed (SLS) without encoder with FSO-12	+Q966 +Q973	□	–	–	–	–	–
Emergency stop, configurable category 0 or 1 with STO and FSO-12	+Q979 +Q973	–	□	–	□	□	–
Earth fault monitoring, earthed mains		●	●	–	●	●	–
Earth fault monitoring, unearthed mains	+Q954	–	□	□	□	□	–
ATEX thermal motor protection		□	–	–	–	–	–
Approvals							
CE		●	●	●	●	●	●
UL, cUL		□	□	□	□	□	□
CSA		□ ³⁾	□ ³⁾	□ ³⁾	□ ³⁾	□ ³⁾	□ ³⁾
EAC (EAC has replaced GOST R) ²⁾		●	●	●	●	●	●
RoHS		●	●	●	●	●	●
C-Tick		● ³⁾	● ³⁾	● ³⁾	● ³⁾	● ³⁾	● ³⁾
TÜV Nord certificate for STO		● ⁴⁾	–	–	–	–	–
TÜV Nord certificate for FSO-12		□ ³⁾	–	–	–	–	–

- Standard
- Selectable option, with ordering code
- Not available

Notes

- ¹⁾ Not available for resistor D151
- ²⁾ EAC will replace GOST R
- ³⁾ Pending
- ⁴⁾ R6i to R7i 690 V pending
- ⁵⁾ For DSU 6-pulse: disconnecter up to 2×D8T, air-circuit breaker ≥ 3×D8T.
For DSU 12-pulse: disconnecter up to 4×D8T, air-circuit breaker 6×D8T.
EMC 1st environment, unrestricted distribution (category C2) (max 1000 A)
- ⁶⁾ R1i to R4i for cabinet, individual for R6i to n×R8i.
Common for cabinet for R1i to R5i, individual for R6i to n×R8i.

- ⁷⁾ Conducted emission and immunity are fulfilled with standard filtering.
Radiated emission and immunity are as option (cabinet construction).
- ⁸⁾ Standard for frame sizes R6i to 10×R8i
- ⁹⁾ Optional in frame sizes R1i to R8i and 400 V/500 V
- ¹⁰⁾ Check availability from your local ABB
- ¹¹⁾ 400 to 500 V disconnecter and contactor up to 2×R8i, 690 V disconnecter and contactor up to 3×R8i
- ¹²⁾ 400 to 500 V air circuit breaker ≥ 3×R8i, 690 V air-circuit breaker ≥ 4×R8i
- ¹³⁾ Not available for 1-phase brake unit
- ¹⁴⁾ Check availability for 3-phase dynamic brake unit
- ¹⁵⁾ Available only as 6-pulse D8T

Expertise at every stage of the value chain

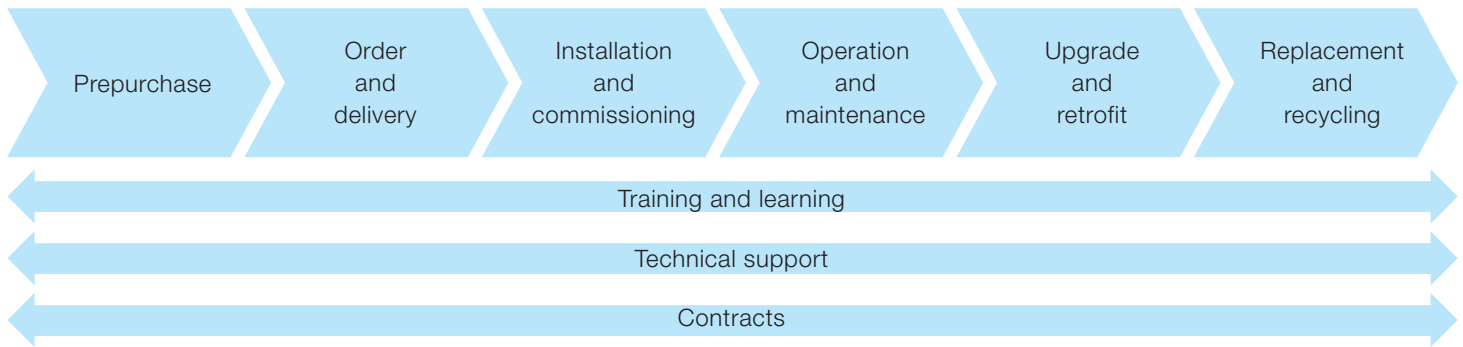

The services offered for ABB low voltage drives span the entire value chain, from the moment a customer makes the first enquiry through to disposal and recycling of the drive. Throughout the value chain, ABB provides training and learning, technical support and contracts. All of this is supported by one of the most extensive global drive sales and service networks.

Pre-purchase

ABB provides a range of services that help guide the customers to the right products for their applications. Examples of services include correct drive selection and dimensioning, energy appraisal, harmonic survey and EMC assessment.

Order and delivery

Orders can be placed through any ABB office or through ABB's channel partners. Orders can be placed and tracked online.

ABB's sales and services network offers timely deliveries including express delivery.

Installation and commissioning

While many customers have the resources to undertake installation and commissioning on their own, ABB and its third party channel companies are available to advise or undertake the entire drive installation and commissioning.

Operation and maintenance

Through remote monitoring, ABB can guide the customer through a fast and efficient fault-finding procedure as well as analyze the operation of the drive and the customer's process. From maintenance assessment to preventive maintenance and reconditioning of drives, ABB has all the options covered to keep its customers' processes operational.

Should corrective maintenance of drives be needed, ABB offers on-site and workshop repair, fully backed up by the most extensive spare holding.

Upgrade and retrofit

An existing ABB drive can often be upgraded to the latest software or hardware to improve the performance of the application.

Existing processes can be economically modernized by retrofitting the latest drive technology to mechanical control equipment, such as inlet guide vanes or dampers or older generations of drives.

Instead of replacing an entire drive or drive system, it is often more economical to modernize the old installation by reusing all relevant parts of the original equipment and purchasing new where necessary.

Replacement and recycling

ABB can advise on the best replacement drive while ensuring that the existing drive is disposed in a way that meets all local environmental regulations.

Entire value chain services

The main services available throughout the value chain include:

- Training and learning – ABB offers product and application training in classrooms and on the Internet.
- Technical support – At each stage of the value chain, an ABB expert is available to offer advice to keep the customer's process or plant operational.
- Contracts – Drive care contracts and other types of agreements, from individual services through to complete drive care covering all repairs and even drive replacements, are available.

Secure uptime throughout the drive life cycle

ABB follows a four-phase model for managing the life cycles of its drives. The life cycle phases are active, classic, limited and obsolete. Within each phase, every drive series has a defined set of services.

Examples of individual services are drive selection and dimensioning, installation and commissioning, preventive and corrective maintenance, remote monitoring and intelligent diagnostics, technical support, upgrade and retrofit, replacement and recycling plus training and learning.

In the active phase the drive is in serial production. The drive, with complete life cycle services, is available for purchase.

In the classic phase, the serial production of the drive has ended. The drive, with complete life cycle services, is available for plant extensions.

In the limited phase, the drive is no longer available. The life cycle services are limited. Spare parts as well as maintenance and repair services are available as long as materials can be obtained.

In the obsolete phase, the drive is not available. ABB cannot guarantee availability of services for technical reasons or within reasonable cost.

To ensure the availability of complete life cycle services, ABB recommends that a drive is kept in the active or classic phase by upgrading, retrofitting or replacing.

In the classic phase ABB carries out an annual review for each drive life cycle plan. Should any changes to the availability or duration of the services be necessary, ABB gives a life cycle announcement indicating eventual change of life cycle phase and/or any change in the duration of services.

In the limited phase, ABB issues a life cycle phase change announcement, half a year prior to shifting the product into the obsolete phase.

Maximizing return on investment

The four-phase life cycle management model provides customers with a transparent method for managing their investment in drives. In each phase, customers clearly see what life cycle services are available, and more importantly, what services are not available. Decisions on upgrading, retrofitting or replacing drives can be made with confidence.

ABB drive life cycle management model

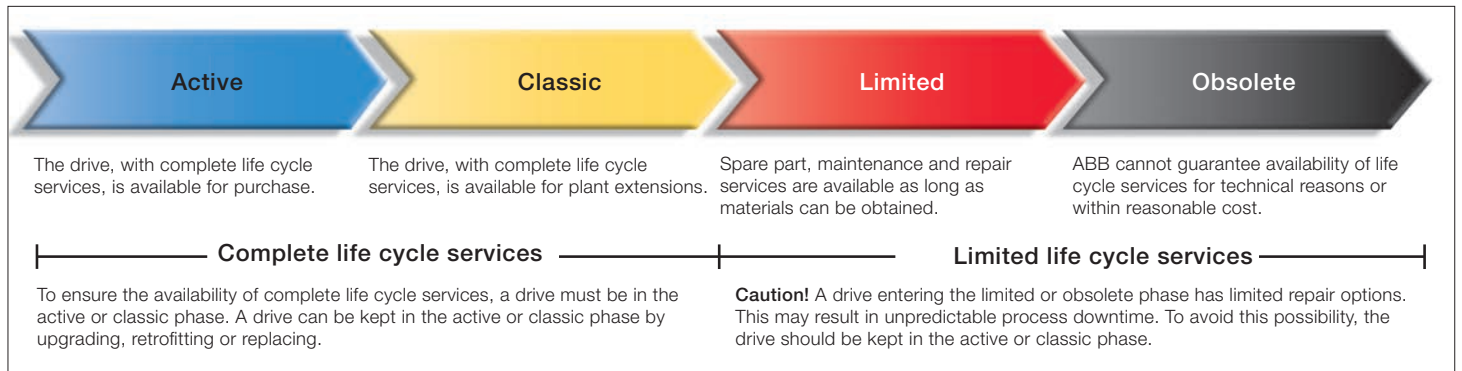

Contact us

For more information please contact your local ABB representative or visit:

www.abb.com/drives

© Copyright 2014 ABB. All rights reserved.
Specifications subject to change without notice.



ACS880 multidrives
web page

3AUJA0000139404 REV E US 19.12.2014 #17379

Power and productivity
for a better world™

